



STELLAR® 4420 TECHNICAL SPECIFICATION GUIDE

4420

Service Crane and T1-11 Service Body



Our People. Our Products.

STELLAR® 4420 TECHNICAL SPECIFICATION GUIDE

■ SPECIFICATION INFORMATION

Crane Rating:	16,000 ft-lbs (2.23 ton-meters)
Standard Boom Length:	10' (3.05 m) from CL of Crane
Boom Extension:	
• 1st stage:	Hydraulic 60" (152.4 cm)
• 2nd stage:	Manual 60" (152.4 cm)
Max. Horizontal Reach:	20'9" (6.32 m) from CL of Crane
Max. Vertical Lift: (from crane base)	21' 6" (6.55 m)
Boom Elevation:	-5° to +80°
Stowed Height: (crane only)	33.5" (85.1 cm)
Mounting Space Req:	18" x 15" (45.7 x 38.1 cm)
Shipping Weight:	1050 lbs (475 kg)
Controls:	Radio control standard for all functions
Winch	
• Rope Diameter:	5/16" (.794 cm)
• Line Pull Speed:	25 ft/min (7.62 m)
• Max. Single Part Line:	2000 lbs (905 kg)
• Max. Double Part Line:	4000 lbs (1815 kg)
Rotation:	370° power (worm gear)
Lifting Capacities:	1600 lbs @ 10' (725 kg @ 3.05 m) 800 lbs @ 20' (365 kg @ 6.10 m)
Power Supply Required:	12-volt power unit 2.0 gpm @ 2600 psi (7.57 lpm @ 179 bars)

Available in hydraulic version also.

■ DEFINING CHARACTERISTICS

Planetary Drive Winch System

To maximize winch speed, Stellar Industries has incorporated a planetary drive winch system with line speeds up to 25-feet per minute. In addition to speed, the planetary winch also provides mechanical and hydraulic breaks for added security.

Hexagonal Boom Design

Hexagonal booms are stronger and greatly reduce boom flex and side to side movement.

Greaseless Bushings

Maintenance free greaseless bushings.

Stainless Steel Pivot Pins

Lower maintenance and extend life.

20' 9" of Reach

Hydraulic 1st stage extension. Manual 2nd stage extension.

Dual Acting Counter Balance Valves

Integrated into cylinders.

Flip Sheave Standard

Anti Two-Block Device

■ 4420 CAPACITY CHART

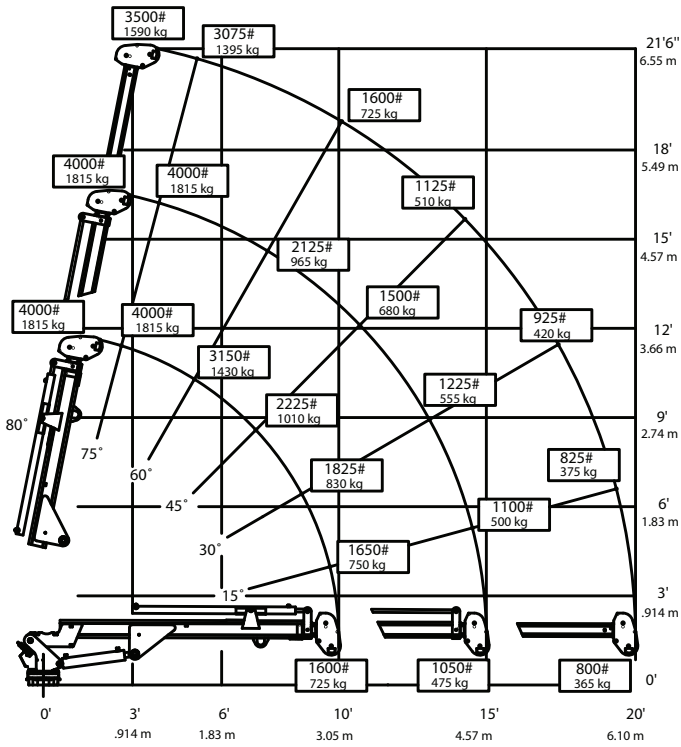

Weight of load handling devices are part of the load lifted and must be deducted from the capacity.

Maximum 1 - part line capacity is 2000 lbs. (905 kg). For greater loads, use 2 - part line.

■ GEOMETRIC DIMENSIONS

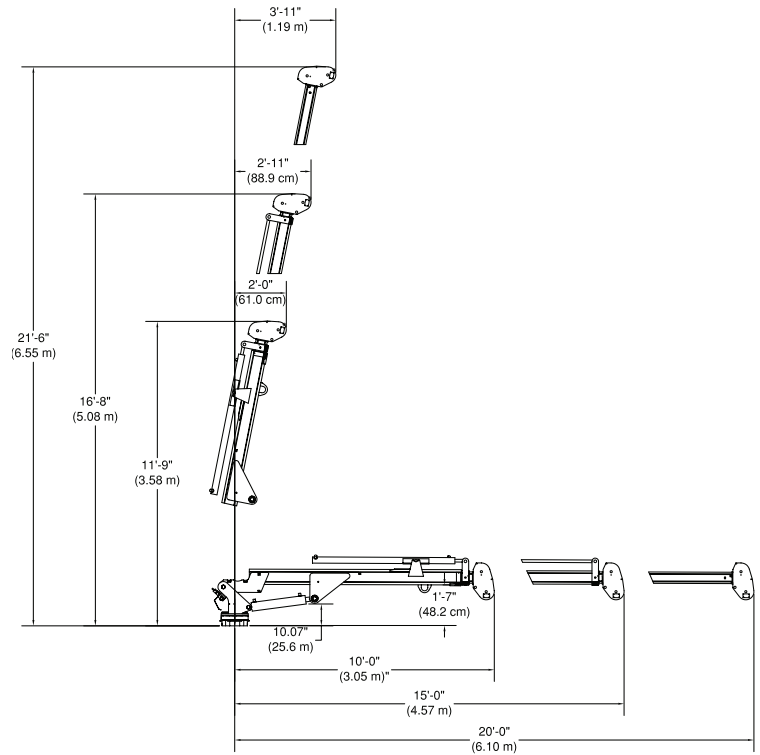

■ ROTATIONAL CLEARANCE

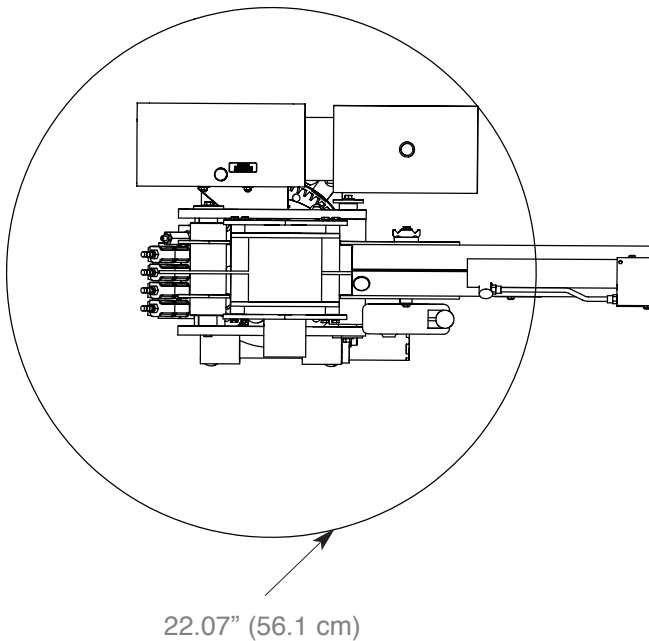

■ HOLE MOUNTING DETAIL

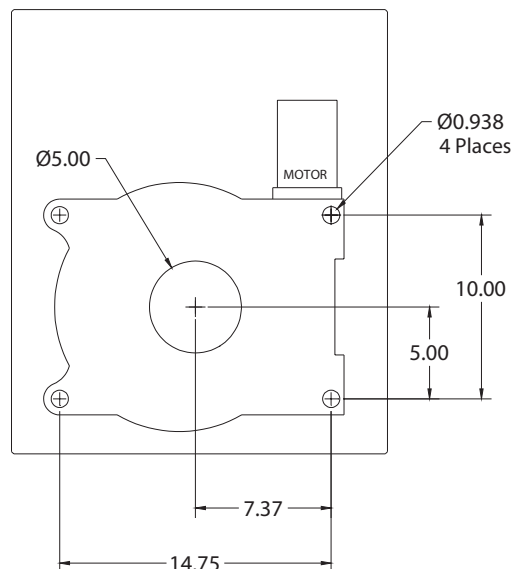

■ Service Bodies

T1-11 Service Body

Applicable Chassis: 16000 GVWR to
19000 GVWR Chassis

Crane Models: 3315
4420
5520
6620
6628

Cab to Axle: 84" (213.36 cm)
Body Length Nominal: 133" (337.82 cm)
Body Height: 44" (111.76 cm)
Body Width: 94" (238.76 cm)
Compartment Depth: 22" (55.88 cm)
Floor Width: 50" (127 cm)
Net Weight: 3220 lbs (1460.37 kg)

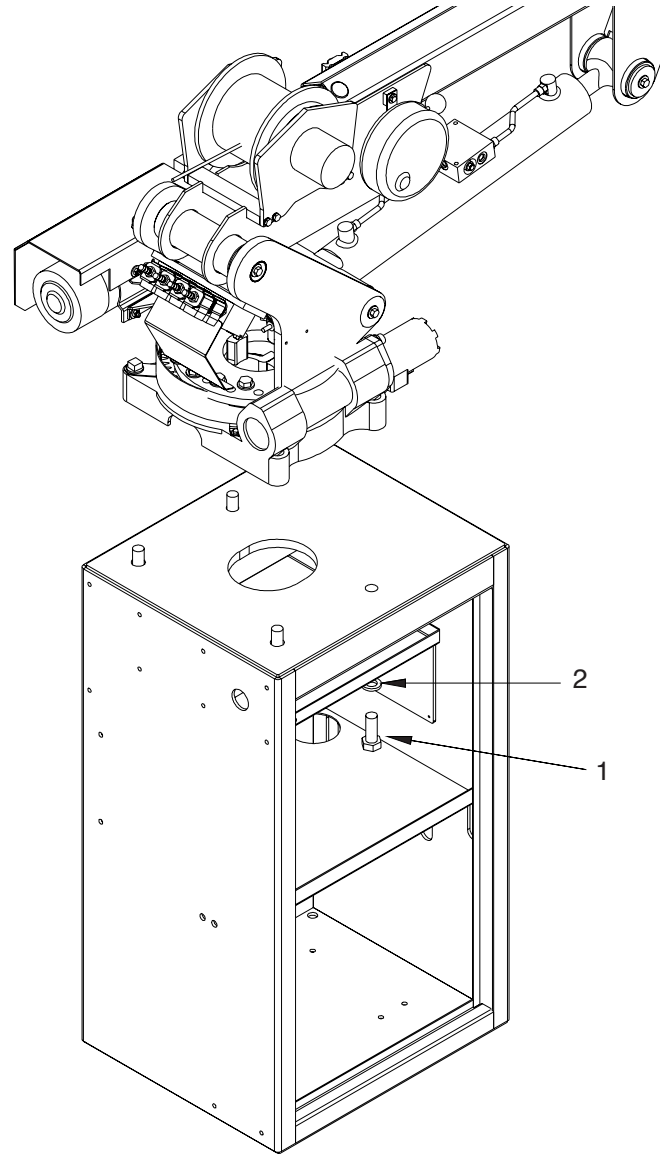
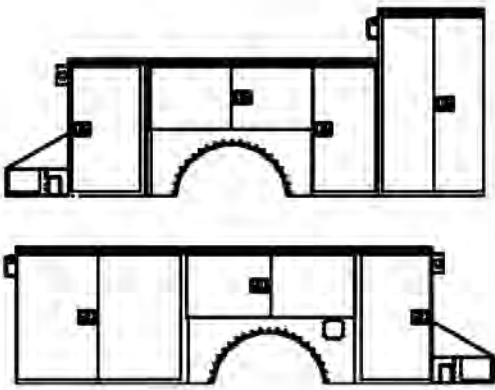

Item	Part	Description	Qty.
1	17688	Cap Scr 0.88-9x2.25 HHGR8	4
2	8648	Washer 0.88 SAE GR8	4

Your local dealer:



Our People. Our Products.

190 State Street
P.O. Box 169
Garner, IA 50438
Telephone: (641) 923-3741 • (800) 321-3741
Fax: (641) 923-2812
Internet: www.stellarindustries.com
Email: sales@stellarindustries.com

An Employee Owned Company.
Copyright © 2008 Stellar Industries, Inc.