



REFUSE & RECYCLING BODY COMPANY

CURB MASTER SERIES

Dual Side Loader



Trough Covers and Plastic Wind Flaps Keep Commodity From Escaping



Load With Blade In Any Position and Pack-on-the-Go



Low 35 inch Loading Height and Up To 2 Cart Tippers Per Trough

KANN Manufacturing Corporation

210 Regent Street
PO Box 400
Guttenberg IA 52052 0400

Tel (563) 252 2035
Fax (563) 252 3069
E-mail sales@kannmfg.com
Web www.kannmfg.com

04/2006
SPECIFICATIONS SUBJECT TO CHANGE WITHOUT NOTICE



REFUSE & RECYCLING BODY COMPANY

CURB MASTER SERIES

Dual Side Loader



FEATURES

FUNCTION

- 10 sec trough cycle
- 30 sec compactor cycle
- 95 sec full eject cycle
- Pack-on-the-go

GENERAL

- 9, 12, 14, 18, 21, 23, 27, 30, and 32 yd³ body capacities
- 3 yd³ hopper capacity
- 100 in body height above chassis frame with trough down
- 144 in body height above chassis frame with trough up
- 96 in body width
- 4 FT x 7 FT (28 FT²) hopper opening
- 1.0 yd³ single or dual trough capacity
- 1200 LB maximum trough lift capacity
- Trough loading height 2 in below chassis frame (approximately 35 in from ground to trough edge)
- Up to 900 LB/yd³ payload
- 2500 PSI operating pressure
- 100 MESH suction strainer
- 10 MICRON in-line return filter
- 60 GAL reservoir with internal baffles
- Sight/temperature gauge
- 2 single stage, double acting compactor blade cylinders
- 1 telescopic, double acting eject cylinder
- 2 single stage, double acting tailgate cylinders
- 2 or 4 single stage, double acting trough lift cylinders
- Standard light package to comply with DOT and FMVSA standards
- Standard wiring package automatic reset circuit breakers and all wiring loom protected
- Tailgate ajar/overheight, arms overheight, and hydraulic overheat alarms
- White PPG paint
- Tailgate safety props
- Front mount pump
- Body clean-out

OPTIONS

- Rear underride guard
- Hydraulic tailgate locks with manual overlock
- Hydraulic suction line shut-off valve

CHASSIS

- 54,000-66,000 GVW
- 14,000-20,000 front GVWR
- 40,000-46,000 rear GVWR

SAFETY

- 10 LB or 20 LB fire extinguisher
- Camera (single, dual, and hopper)

AXLE

- Tag
- Pusher
- Steerable tag
- Steerable pusher

TIPPER

- Cart tipper (up to 2 per trough, 500 LB capacity)

TROUGH

- Foldable trough face option

HYDRAULICS

- 3-6 MICRON return line filter
- Transmission mount PTO

LIGHTS

- LED lights
- Safety work light package
- Strobe light

PAINT

- Standard PPG other than white
- Metallic
- Multi-color
- Striping



Each of the 1.0 yd³ capacity dual side loading troughs can have up to 2 cart tippers mounted per trough providing complete versatility of bag, bulk, and cart routes.

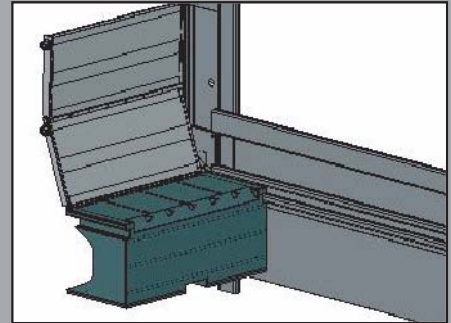

A) The hinged follower cover allows for constant loading without commodity falling behind the compactor blade.

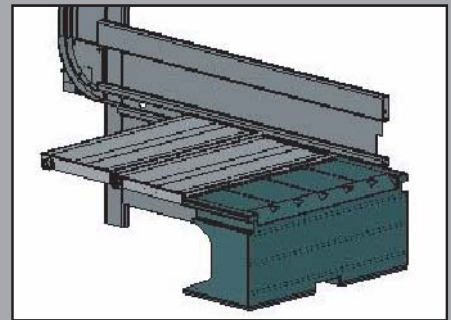

B) The follower cover extends and retracts with the blade.



The full eject push out panel quickly travels the full length of the body and is engineered to eject all types of refuse and recyclables easily and completely clean.