

DATA SHEET  
#NME070

# FOAM TOTE TRAILER



## Description

The Foam Tote Trailer provides large storage capacity of foam concentrate along with the high performance delivery of the patented technology of the Gladiator® nozzle in a complete firefighting package. The trailer is available with single or dual tote tanks in either the 275 gallon or the 330 gallon size. This portable firefighting package provides plenty of flexibility and fire power to your arsenal, and is available with a variety of options which allow you to pick, choose and custom build to suit your needs. Totally self contained and ready to put into service at a moment's notice.

## Features

- Direct nozzle concentrate pick-up connection to tote tank.
- Stainless steel trailer deck rub rails on trailer deck for tote positioning.
- Bright aluminum tread plate.
- Hose bins both sides.
- Non-slip deck surface at monitor base.
- Quick-release tank securing system.
- 3" in-line butterfly valve in monitor riser.
- Trailer is fully DOT compliant and road-ready.

## Applications

The Tote Trailer is an ideal alternative to the handling of drums or pails or relying on a foam tanker during a major flammable liquid incident. With the pre-piped trailer mounted monitor, it can be placed into action immediately upon arrival on the scene, and does not require special positioning since the monitor piping allows for the water supply to be connected to either side of the trailer.

## Specifications

- 7000 GVWR Trailer with electric brakes on both axles. (Surge hydraulic brakes optional)
- 7,000 pound capacity drop-foot front jack and dual 5,000 pound capacity swing-down rear jacks for stabilization.
- Pre-piped MMAM 3 x 2-1/2 aluminum monitor with any 2-1/2" Gladiator Nozzle, 500 to 1000 GPM.
- Water inlet connections either side.
- 3-inch Butterfly Valve with long neck gear operator.
- Quick tote connector for replacing empty tote with full tote.
- Aluminum hose bins either side with capacity for 100 feet of 3 inch hose.



Stainless steel rub rails and quick action clamp



Constructed of bright aluminum tread plate



500, 750 or 1000 gpm Gladiator nozzle for Class A or B foam



Direct Tank Hook-Up to Nozzle



Optional Dual Agent (Foam-Dry Chemical Nozzle)



Optional Vinyl Cover

### Options

- Single Tote Trailer 275 gallon or 330 gallon.
- Red vinyl tote cover.
- 2-1/2" Gladiator Nozzle 500 gpm fixed, metering, or tri-flow.
- 2-1/2" Gladiator Nozzle 750 gpm fixed 1% or 3%.
- 2-1/2" Gladiator Nozzle 1000 gpm fixed 1% or 3%.
- Dry-Chemical Gladiator Nozzle attachment with flows up to 30 pounds per second available.
- Hose bin mounted line proportioners available.
- Monitor inlet piping available in dual Storz connections.

### Notes

- Foam concentrate and tote not included as part of trailer. Foam concentrate and tote must be ordered separately.
- Delivery cost not included.

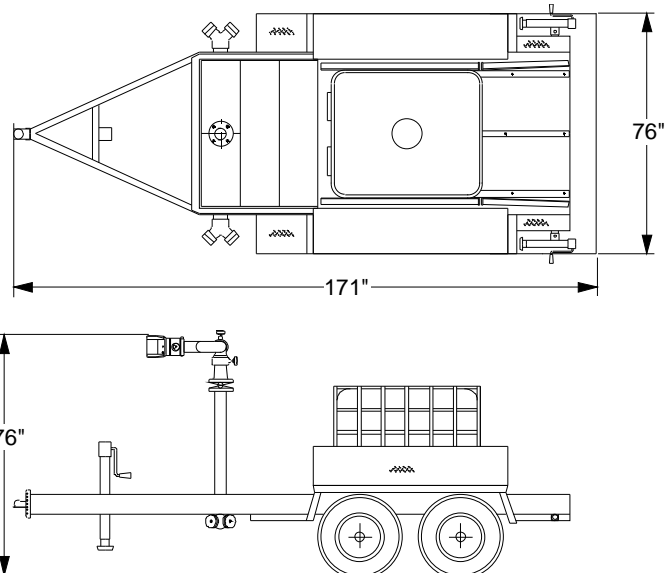

### Ordering Information

**Single Tote Trailer** - Base 7000 GVWR trailer with electric brakes, swing-down jacks, inlet adapters (as noted below with description), pre-piped MMAM 3 x 2-1/2 monitor with any 2-1/2 Gladiator Nozzle 500 to 1000 GPM, 3 inch butterfly valve, quick-connect tote connections, two aluminum hose bins, and pressure/vacuum vent.

**Note:** Trailers noted below do not include foam tote or foam concentrate.

- 5100-1000-1 ..... Single Tote Trailer - (2) Siamese 4" FNPT x 2.5" FSWNH
- 5100-1000-2 ..... Single Tote Trailer - (2) Adapter 4" FNPT x 4" MNH
- 5100-1000-3 ..... Single Tote Trailer - Adapter 4" FIPT Inlet x 4" Storz
- 5100-1000-4 ..... Single Tote Trailer - Adapter 4" FNPSH Inlet x 5" Storz

### Trailer Options:

- 1292-2000-1 ..... Cover, Red Vinyl, for 275 or 330 gallon tote

This information is only a general guideline, and each installation may require modifications to meet the applications or requirements of that situation. The company reserves the right to change any portion of this information without notice. Terms and conditions of sale apply and are available on request.