



MANUFACTURING CORPORATION

REFUSE & RECYCLING BODY COMPANY

Established 1946

ROUTE KING SERIES

Single Axle Front Loader



KANN 26 yd³ Single Axle Full Eject Front Loader for Commercial or Residential Collection of Refuse or Recycling!

For **FREE** Route Demonstration at Your Site Call 800-806-5266

KANN Manufacturing Corporation

210 Regent Street
Post Office Box 400
Guttenberg, IA 52052 USA

Phone 563-252-2035
Fax 563-252-3069
Email sales@kannmfg.com
Web www.kannmfg.com



MANUFACTURING CORPORATION

REFUSE & RECYCLING BODY COMPANY

Established 1946

Route King SERIES

Single Axle Front Loader

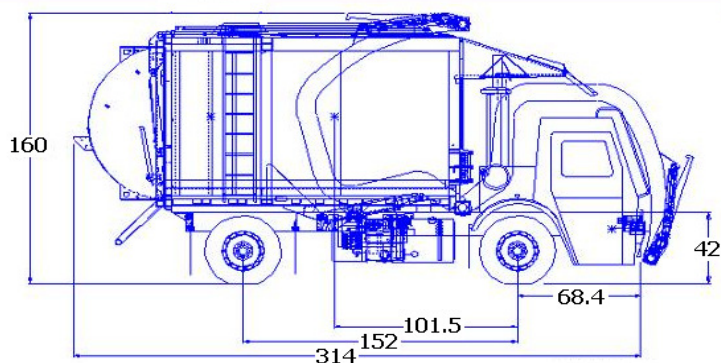

	Front Axle		Front Axle		Total
	lbs.	%	lbs.	%	
Chassis	11,325	72.3%	4,349	27.7%	15,674
Body	5,150	33.2%	10,350	66.8%	15,500
Driver	232	115.8%	-32	-15.8%	200
Empty Weight	16,706	53.2%	14,668	46.8%	31,374
Payload	-789	-10.5%	8,289	110.5%	7,500
Total Weight	15,917	40.9%	22,957	59.1%	38,874

DECLARATIONS:
26 YD BODY
6,000# ARMS
MAX LK 152" WB
AXLES-20,000 FRONT / 26,000 REAR

LIMITS:
FEDERAL BRIDGE LAW = 40,000
FRONT AXLE LIMIT = 20,000
REAR AXLE LIMIT = 20,000



TITLE: CONCEPT
26 CU YD BODY
BRKLE W/ 152" WB
10" BRKLE LAW

NOTE: WEIGHT AND CAPACITY DIMENSIONS ARE ESTIMATED, BASED UPON AVERAGE AVAILABLE. THESE VALUES WILL VARY WITH CHASSIS, BODY, AND TAG SPECIFICATIONS.

Standard Features

Finish Paint Single Color
Front Mount Gear Pump
Auto Lock Tailgate
Cab Shield Canopy Cover
Curved "Uni-Body" Design

Body Side Ladder
Body Sump
Rear Vision Camera
LED Light Package

Side Access Door(s)
Pack-on-the-Go
8000 lb. Arms
Hopper Top Door

Automated Curotto Can Attachment



Semi Automated Kann Carry Can Attachment



Collect Front & Rear Load Bins w/ Kann Adapter



KANN Manufacturing Corporation

210 Regent Street
Post Office Box 400
Guttenberg, IA 52052 USA

FEATURES & SPECIFICATIONS

FUNCTIONS

Load Cycle	23 seconds
Compactor Cycle	25 seconds
Unload Eject Cycle	45 seconds

STANDARD SPECIFICATIONS

* Weights & Dimensions

Body Capacity	14 yd ³
Hopper Capacity	12 yd ³
Body Height	113"
Body Width	96" Maximum
Body Length	
Arms Up	314"
Arms Down	378"
Body Weight	15,500 lbs

* Body Construction

Body Walls	1/8"	AR200
Body Roof	1/8"	80 ksi
Body Floor	3/16"	AR400
Hopper Floor	3/16"	AR400
Hopper Walls	1/8"	AR200
Compactor		
Blade Face	1/4"	AR400
Blade Sides	3/16"	AR200
Tailgate	1/8"	80 ksi
Arms	3/16"	50 ksi
	1/2"	T1 160 ksi

Forks 1" thick T1 160 ksi

* Hydraulics

Operating Pressure	1850 psi
Pump Flow	55 GPM
Oil Reservoir	66 Gallon
Packing Force	88,000
Cylinders	
Compactor	2 x 5.5" Bore
Arm	2 x 5" Bore
Fork	2 x 3.5" Bore
Tailgate	2 x 3" Bore
Hopper Cover	1 x 2.5" Bore
Hydraulic Hose	4 to 1 burst
Return Filter	10 micron

For FREE Route Demonstration at Your Site Call 800-806-5266