

# Specification Sheet

# LR 50

**Series: LR 50 Outdoor Vacuum Collector**

**Date: 23.02.10**

**Subject: Technical Information and Data**

**Drawing: I13233, Rev C**

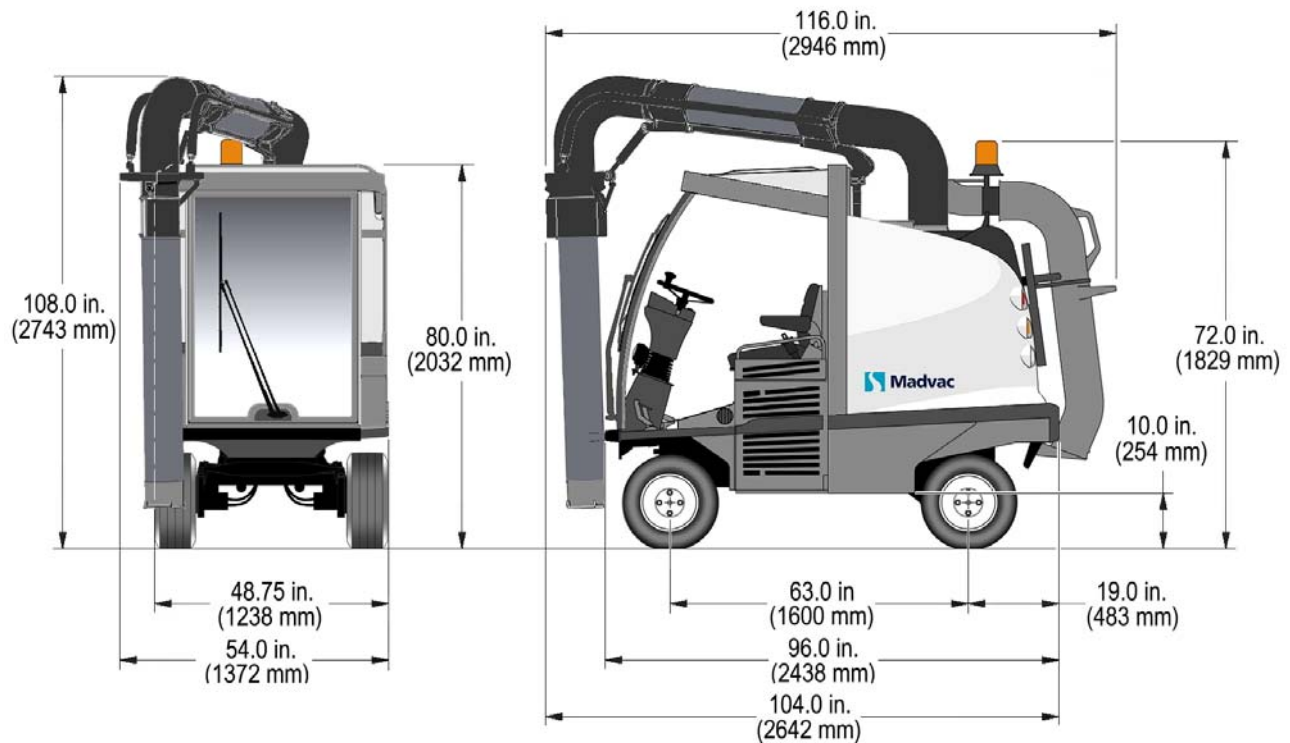

## Data and Performance Information

Capacities		Vacuum System	
Fuel tank	9.3 gal. (35 L)	Vacuum Rating	2,900 CFM
Hydraulic system	12.5 gal. (48 L)	Air Flow Speed	8,400 ft./min
Litter Capacity	100 – 120 gal. (378 L – 454 L)	Static Pressure @ Closed Inlet	20 in. of water gauge
Engine Data		Controls	
Model	Kubota Diesel D1105-E3B	Steering	Automotive type, power assisted
Displacement	68.53 cu in. (1123 cc)	Drive System	Heavy duty hydrostatic
Gross rated power	24.8 hp (18.5 kW) @ 3000 rpm	Traction	
Legislation compliance	EPA Tier 4	Drive	Front wheel drive, optional four-wheel drive
Air Cleaner	2 stage Donaldson with restriction indicator	Maximum Forward Speed	12 mph (19 km/h)
Litter Collection System		Tire	20.5 x 8.0 – 10
Type	"flow through" system, 2 to 1 compaction ratio, with fibrous polypropylene bags	Brakes	Hydrostatic front brake. Rear mechanical disc parking brake.
Container Construction	16 gauge, powder-coated steel	Curb Weight	2770 lbs (1256 Kg) Including Optional Cab
Vacuum Hose	8 in. (203 mm) ø joystick controlled		
Frame/Body			
	-Heavy gauge steel body on a welded 1/4 in. structural steel frame.		
	-Storage compartment		
	-Electrostatic powder-coated paint		

\* Illustration may show optional equipment.

Due to continuous product development Allianz Madvac reserves the right to alter specifications without prior notice.



**Madvac Inc.**  
 1690 Eiffel, Boucherville  
 Québec J4B 7W1, Canada  
 Tel : 1 866 462-3822  
 Fax : 1 (450) 616-8103  
 E-Mail : parts@madvac.com  
 Web : www.madvac.com

