

Convenient and safe, and as multifunctional as ever

The M 27: Maximum efficiency is guaranteed

High performance and versatile

Powerful implement carrier and high transporting performance result in an attractive price-performance ratio: This is the formula for success of our M 27. A real Multicar which includes all of the strengths of its predecessors and is provided with innovative solutions to simplify completion all of today's workloads in municipalities, gardening and landscaping, building industry and waste disposal.

Ergonomic and safe

- The ergonomic space-frame cab provides freedom of movement and optimum visibility of the equipment and surrounding area
- Precise control of the equipment directly from the cab using the joystick
- Simple change to crawling gear when delicate manoeuvring is required

Modular and economic

- The modular vehicle concept ensures it can be used for years to come, optional equipment can be replaced or retrofit later simply and easily
- The high quality of all the assemblies, long periods between servicing and simple diagnosis options guarantee a long service life and low consequential costs

Quality made in Germany

Multicar has been developing and producing in Germany for over 50 years!



Compact and manoeuvrable with a width of 1.62 m and turning radius of just 5.4 m



Robust attachment points at the front, top and rear, quick-change system at the front and equipped with ball coupling system for economic one-man operation





Robust and strong
with up to 2.9 t
load capacity and
7.5 t gross
towing capacity



Variable hydraulic availability
of the tipper with 1-circuit
hydraulics to mobile 2-circuit
and 3-circuit hydraulics for
universal implement carriers



High performance and economic:
Low-noise, 2-litre turbodiesel engine
from VW producing 75 kW (102 Hp),
complies with EURO 5 and EEV
standard for use in all low emission zones



Safe and stays on track
thanks to the independent
suspension at the front,
ventilated disc brakes
and 4-channel ABS on
all four wheels



Compact, high performance and versatile

Three convincing arguments for the M 27



The M 27 B as a three-way tipper

Multicar provides three basic models of the M 27, each one perfectly designed to fulfil your demands and which you can upgrade individually to adapt it to your specific purposes.

Multicar M 27 T

The powerful transporter with high transport capacity. Available as a three-way tipper with short or long wheelbase and alternatively with 4x2 or 4x4 drive.

The ideal vehicle for:

- transporting on roads and in open terrain
- loading debris and package freight on the three-way tipper
- increasing transport capacity by attaching a trailer (trailer load up to 3.5 t)

Multicar M 27 B

The robust transport vehicle with proven 1-circuit hydraulics (up to 45 l/min and 200 bar), perfectly suited for driving stationary operated attachments and devices.

The ideal vehicle for:

- transport with a three-way tipper, skip loader or dumper
- refuse compactor attachment
- aerial work platform
- loading crane
- gully cleaner

Multicar M 27 C

The 4x4 professional implement carrier with 2 or 3-circuit hydraulics and summation circuit. Can drive several devices simultaneously and independently of each other.

The ideal vehicle for:

- winter service (gritter and snow plough or snow sweeper)
- mowing implements and weed brushes
- foliage and waste vacuum
- road sweeper
- sluicing equipment
- drain sluicing

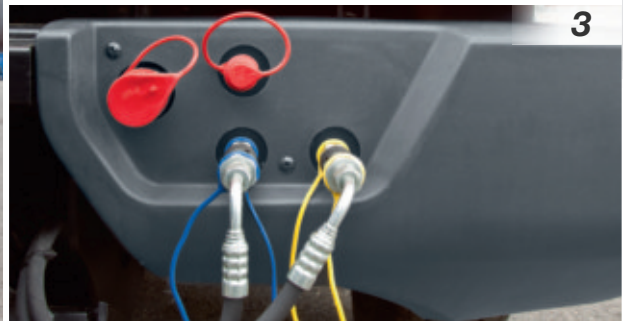

1) Compact

With a width of just 1.62 m and a turning radius of a mere 5.4 m, the M 27 is fast and manoeuvrable in confined pedestrian precincts and parks.

2) High performance

75 kW (102 Hp) enable the M 27 to accelerate fast 90 km/h – with a load capacity up to 2.9 t and permissible trailer load up to 3.5 t!

3) Versatile

The three attachment points and various hydraulics mean that the M 27 provides the best conditions for the widest range of implements and attachments.

The M 27 B
deployed as
a compact
skip loader

Hundreds of tasks, one solution: the multifunctional M 27

High level of flexibility

The wide range of implements available for the max. three attachment points render the M 27 a versatile all-rounder. It can be re-equipped quickly for the next job in just a few steps enabling it to be used all-year-round and round-the-clock on roads, in pedestrian precincts or in parks.

Wide range of deployment

Whether for municipalities or road maintenance, gardening and landscaping, service or building industry: The Multicar M 27 is ideal for use everywhere where compact implement carrier work is necessary.

Excellent efficiency

Deploying the M 27 can pay you back in many ways. The high quality materials used, the first class workmanship and excellent corrosion resistance ensure a long service life. The high-performance turbo diesel engine has low fuel consumption, thus reducing operating costs. The service-friendly design means that maintenance work can be completed quickly and economically.



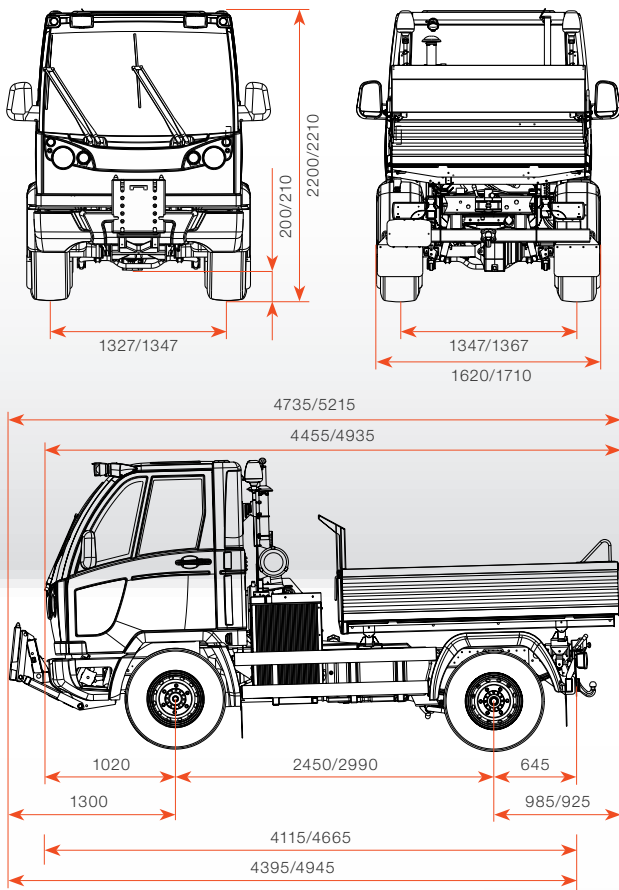

You can count on Multicar at all times

We provide expert advice prior to purchase and excellent financing and leasing options. After purchasing the high quality product, we provide experienced after-sales service 24 hours a day and are close by!

Hydraulics	Multicar M 27 T with tipping hydraulics	Multicar M 27 B with 1-circuit hydraulics	Multicar M 27 C with 2-circuit hydraulics	Multicar M 27 C with 3-circuit hydraulics
Tipping hydraulics	Max. 10 l/min; Max. working pressure 160 bar	Max. 10 l/min; Max. working pressure 160 bar	Max. 10 l/min; Max. working pressure 160 bar	Max. 10 l/min; Max. working pressure 160 bar
Stationary 1-circuit hydraulics*	-	Max. 45 l/min; Max. working pressure 200 bar	-	-
Mobile 2-circuit hydraulics*	-	-	Max. 45 l/min; Max. working pressure 200 bar	-
Mobile 3-circuit hydraulics*	-	-	-	Max. 2 x 45 l/min; Max. working pressure 200 bar
Summation circuit	-	-	-	Max. 1 x 90 l/min; Max. working pressure 200 bar

*including front control functions: raise, lower, floating position and pivot