

sterili[®] **KONO**



ST1175

**Heavy duty mobile column lift
40,000 lbs / 17.500 kg**

FOR LIFTING EXCEPTIONALLY
HEAVY VEHICLES



Active worldwide

Stertil-Koni products are innovative and characterized by excellent value-for-money. This advantage results from an efficient production process by which custom work is accomplished with standard components. The use of welding robots, CAD systems and other advanced techniques lowers production costs while at the same time increasing quality. Stertil-Koni is the world market leader with its mobile column lifts. Stertil-Koni is the first vehicle lift manufacturer to achieve ISO 9001 certification. No wonder that Stertil-Koni products are being exported all over the world.

The company has its sales organizations in the United Kingdom, United States, Germany, France, Poland and the Netherlands.

Throughout the world Stertil-Koni works closely together with its exclusive distributors.

ST1175: mobile c

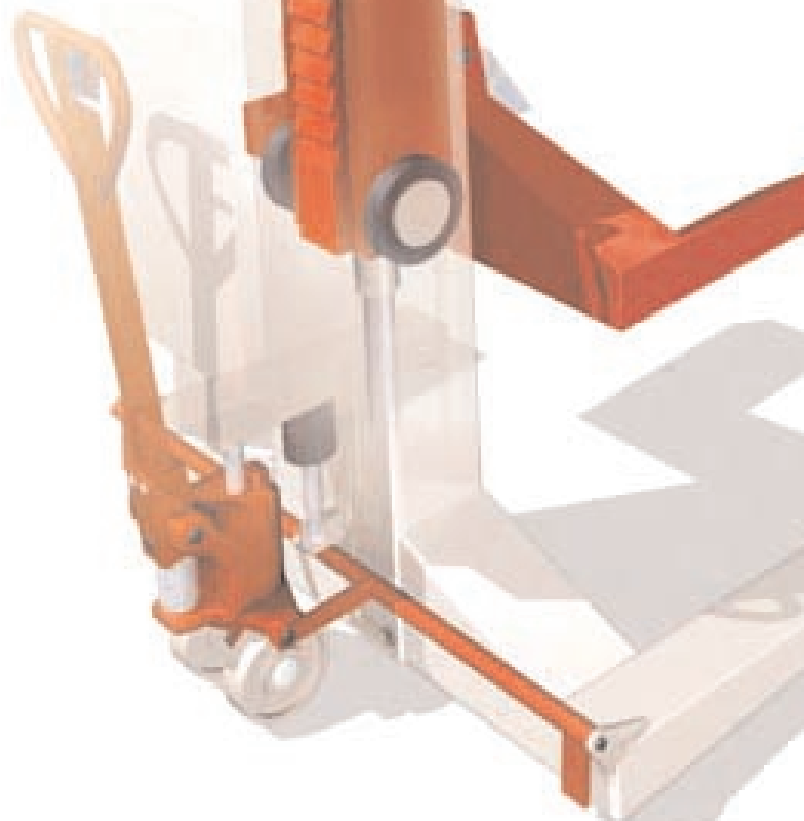

column lift for lifting exceptionally



The flagship of our program is the mobile column lift, which is available with lifting capacity from 10,000 lbs. / 5.500 kg. up to 40,000 lbs. / 17.500 kg. per column. The advanced Stertil-Koni mobile column lift has earned its popularity because it has cleared the way for efficient and flexible workshop management.

The ST 1175 hydraulic mobile column lift is used for lifting exceptionally heavy vehicles, e.g. aircraft tractors, mining vehicles, trains, boxcars, locomotives, etc.

The number of lifting columns required depends on the weight of the vehicle or the number of axles.

Each lifting column has a lifting capacity of 40,000 lbs. / 17.500 kg. Consequently, four columns have a total lifting capacity of 160,000 lbs. / 70.000 kg. The total lifting capacity can be increased by adding more columns up to a maximum of 32. The Stertil-Koni mobile columns are user-friendly and thoroughly reliable. Parts are in stock and available for up to 25 years after production.

Hydraulic lifting system

Hydraulic lifting system with a minimum of moving parts. An important advantage is the absence of parts sensitive to wear such as spindles, nuts or chains, resulting in an exceptionally low maintenance interval and a very long life span.

Superior Engineering

The microprocessor-controlled system on the lifting columns ensures full synchronisation during the raising and lowering of the columns.

Each lifting column is equipped with a position sensor, which transmits the lifting height to the control system. The exact tracking offers unique advantages

- individual and paired operation from the column concerned.
- operation of the system from every column.
- automatic self-diagnosis with LED fault indication.

heavy vehicles

Flexible

Every mobile column lift operates, most importantly of all, safely and quickly, for loads up to 40,000 lbs. / 17.500 kg.

By adding more columns you can increase this lifting capacity up to 1,280,000 lbs. / 560.000 kg.

Lifetime guarantee

The patented, synthetic runner system is self-lubricating and therefore does not require any maintenance. It comes with a lifetime guarantee. The hydraulic system works fast, trouble-free and is tested with 50,000 cycles at maximum load. Stertil-Koni's mobile column lifts are durable and can be used indoors and outdoors.

Easily manoeuvred

The pallet truck mechanism is equipped with a patented automatic overload protection.

When lifting any weight, the pallet truck mechanism lowers automatically to the down position.

Due to its specifically designed base frame with retractable wheels, the Stertil-Koni column is the only heavy-duty column in the world that can be easily moved around by one person.

Short lifting time

With a raising and lowering time of 190 seconds the ST 1175 is very fast, and is the fastest heavy duty



lifting columns in the world. The lifting height is over 2 metres, therefore it is comfortable to work with, even for tall people.

Unique cables

The sturdy connecting cables with steel inside can be disconnected at both ends. They easily withstand the pressure of tyres.

Patented Locking unit

The patented, mechanical locking unit works independently of the lifting system and is always active. In the event of power failure the column lifts can still be lowered.



FLEXIBLE

Wheel adapters

Two adapters are supplied with every mobile column lift, which are necessary when lifting vehicles with smaller diameter wheels.

Two adapters are required for tyre size of R17 (900 mm - 35 1/2") to R22.5 (1140 mm - 45").

One adaptor is required for tyre size 16.00"/25 (1.450 mm - 57")

No adaptors are used for tyre size 18.00"/25 (1.600 mm - 63")

Special Pick-up Points

The Stertil-Koni mobile column lifts are universally applicable. With interchangeable pick-up points it can lift various vehicles. Stertil-Koni is able to manufacture specific custom-made pick-up points to meet the customers lifting requirements.

Options

- Lighting set 2 pieces per column
- Remote control, including 10 metre cable
- Custom-made pick-up points to meet the customers lifting requirements
- Custom-made crossbeams
- Axle support with a capacity of 20 tons. (44.000 lbs)
- RAL colours to customer's specifications



Specifications

Lifting capacity:	17.500 kg. 40,000 lbs per column
Lifting speed:	600 mm. / min. 20" / min.
Lifting height:	2,06 metre 81"
Motor power:	2.2 kW 3 Hp per column
Weight:	1.200 kg. 2,650 lbs per column
Wheel diameter:	1.600 mm. max. 63" max.

Maximum safety

- CE approved
- Low voltage control box
- Automatic overload protection
- Automatic activation of electromagnetic locking system (prevents uncontrolled lowering)
- Microprocessor-controlled tracking system
- Dead-man's operation
- Emergency switch on every column
- Splash-proof electrical system (IP65)
- Cable connections are fully looped, when interrupted the system switches off automatically.

More information?

Should you require more information or more specific data on the ST 1175, or any other Stertil-Koni quality product, please contact us. We shall be glad to be of service to you.

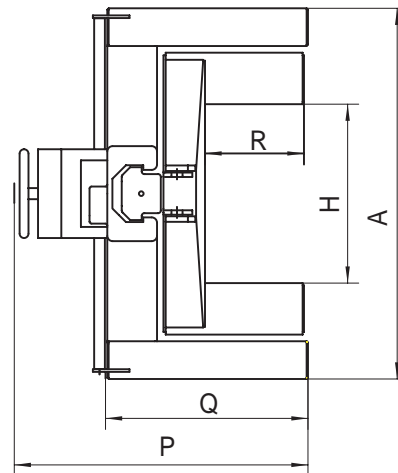
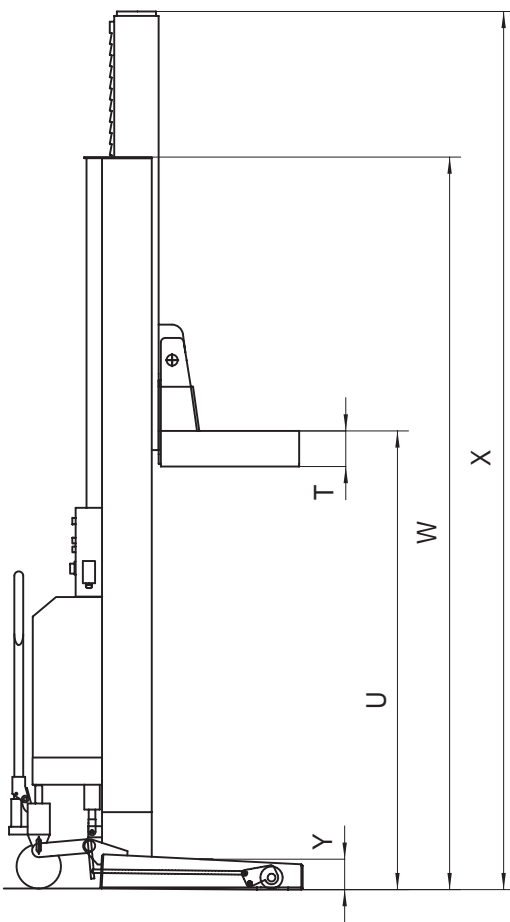

A	H	P	Q	R	T	U	W	X	Y
65 3/4"	31 3/4"	52"	36"	17 3/4"	6 1/4"	81"	130"	155 3/4"	5 3/8"
1670	806	1323	912	450	160	2060	3300	3956	137



UDT

stertil **KONI**

Stertil B.V., P.O.Box 23, 9288 ZG Kootstertille (The Netherlands) Tel. +31(0)512 334444 Telefax +31(0)512 334430

E-mail: info@stertil.nl Internet: www.stertil.nl



A MEMBER OF THE KROYMANS A.R.M.-STOKVIS GROUP