

# SZ & Q Series Turbine Meter Installation Instructions



## **Recommended Piping:**

Isolation Valves upstream and downstream of the meter are recommended. A by-pass will facilitate maintenance or calibration. A “Y” strainer can be installed upstream of the meter run for added protection. SZ and Q Series meters can be installed in Vertical or Horizontal piping.

A minimum of 5 Pipe Diameters UPSTREAM & 3 Pipe Diameters DOWNSTREAM of straight, unobstructed pipe of the same diameter as the meter is required for accurate measurement\*

*For example:* If the meter is a 3” meter, it needs 15” of straight 3” pipe Upstream and 9” of straight 3” pipe Downstream.

\*Turbine meters are inferential meters. They measure gas by inferring the flow from the relative velocity at which the turbine spins. Any obstructions or pipe configuration that severely changes the flow profile of the gas such as reducers, valves, 90° bends can potentially alter the accuracy of the meter.

## **Environmental Considerations:**

SZ Series meters can only be installed Inside

Q Series Meters can be installed Inside or Outside

## **Start Up:**

Pressurize and Depressurize SLOWLY

To prevent over-speeding, the down stream valve should be closed when pressurizing the meter.

When the meter is fully pressurized, SLOWLY open the downstream valve.

## **Maintenance:**

The meters have permanently lubricated bearings and require no maintenance if the gas is clean and dry and the meters are operated within their rated capacities.

## **Pulse Output:**

SZ Series have two connectors on the access that allows access to the E1 Pulser – low frequency reed switch and the E200 Pulser High Frequency Proximity sensor – see attached table for details

The Q Series Meters are equipped with 2 separate form A Reed switches. The switches are enclosed in a snap in enclosure that fits on the index. A magnet embedded in the totalizer passes the switches, causing a closure of the switch and creating a pulse.

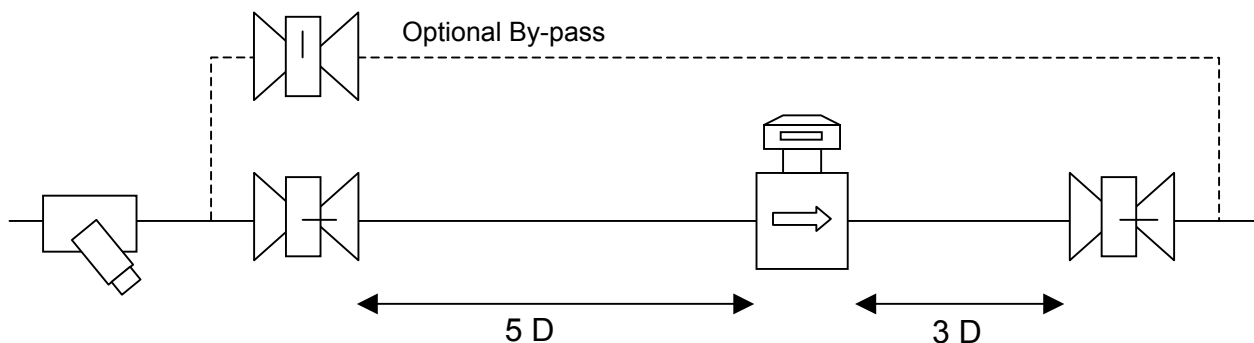

**SZ Series Pulse Output**

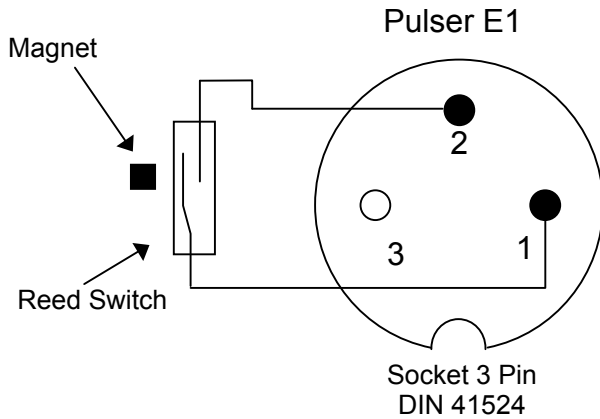

**Low Frequency E1 Reed Contact**

Max Voltage: 24 VDC  
 Max Current: 50 mA  
 Max Capacity: 0.25 Watts

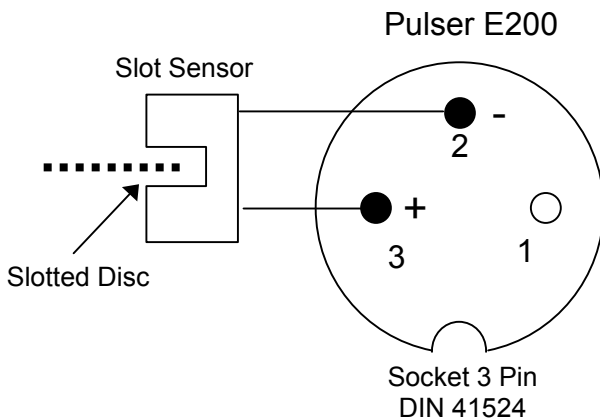

**High Frequency E200 Slot Sensor**

Standard Voltage:  $U_n = 8V_{dc}$   
 Current consumption:  
 Active Surface Open:  $I \geq 3 \text{ mA}$   
 Active Surface Closed:  $I \leq 1 \text{ mA}$

**SZ Pulse Weights**

	<b>SZ-1</b>	<b>SZ-2</b>	<b>SZ-40</b>	<b>SZ-65</b>	<b>SZ-100</b>	<b>SZ-160</b>	<b>SZ-250</b>
E1 Low Frequency Cubic Ft/Pulse	1	1	10	10	100	100	100
E200 High Frequency Pulses/CuFt	500	500	25	25	2.5	2.5	2.5

**Q Series Pulse Output**

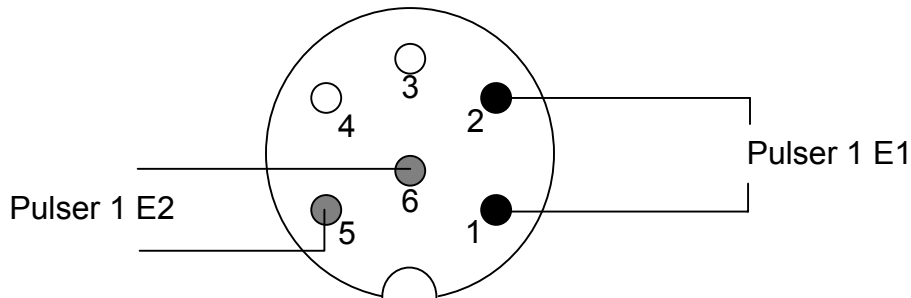

1 Pulse = 100 ACF (Actual Cubic Feet)  
 Max Voltage: 24 VDC  
 Max Current: 50 mA  
 Max Capacity: 0.25 Watts

**Sales & Service:**  
**Istec Corporation**  
**Phone: 973 383 9888 / 973 383 9088**  
**www.istec-corp.com**