

B39 BLUELIFT

The BLUELIFT Series

Back in blue alongside the ReachMaster brand! Meet our new line of aerial lifts from the well-renowned Italian manufacturer Bluelift s.r.l., now exclusively distributed in the US, Canada and Mexico by SKAKO Lift, Inc. Innovation, quality, superior design and above all safety are trademarks of Bluelift s.r.l.. With working heights from 39 to 72 feet, in and outdoor use and access through a single or double door, the BLUELIFT series appeals to a broad range of applications: Rental industry (residential as well as commercial), window cleaners, building maintenance, tree care industry and HVAC operators to mention a few.

- Available in 4 models from 39ft - 72ft
- Pass through a single or double door opening
- Automatic outrigger setting
- Full workheight with 440lbs in the basket
- Remote and wireless control
- 110V to the basket
- Set up on uneven surfaces
- Detachable basket
- FMS (Function Memory System)
- Automatic turret center stop

Model

B39

Working height	39ft
Basket height	33ft
Max outreach	21ft
Basket load	440lbs
Basket dims	4ft7 ³ / ₄ in x 2ft5 ¹ / ₄ in
Basket rotation (opt)	+/-90°
Turret rotation	360°
Height	6ft6 ³ / ₄ in
Length (w/o basket)	11ft1 ³ / ₄ in
Length (w/ basket)	13ft7in
Width (w/o basket)	2ft6 ³ / ₄ in
Footprint	9ft2in
Weight (approx)	4,225lbs
Max pressure, tracks	7.5psi
Max pressure, footplate	65.3psi
Track size (per track)	44in x 6 ¹ / ₂ in
Foot pad size (per pad)	48 ¹ / ₂ sq in
110V drive motor	Standard
Honda, single cylinder	Standard
Hatz diesel engine	Option
Honda upgrade	Option

We reserve the right to alterations

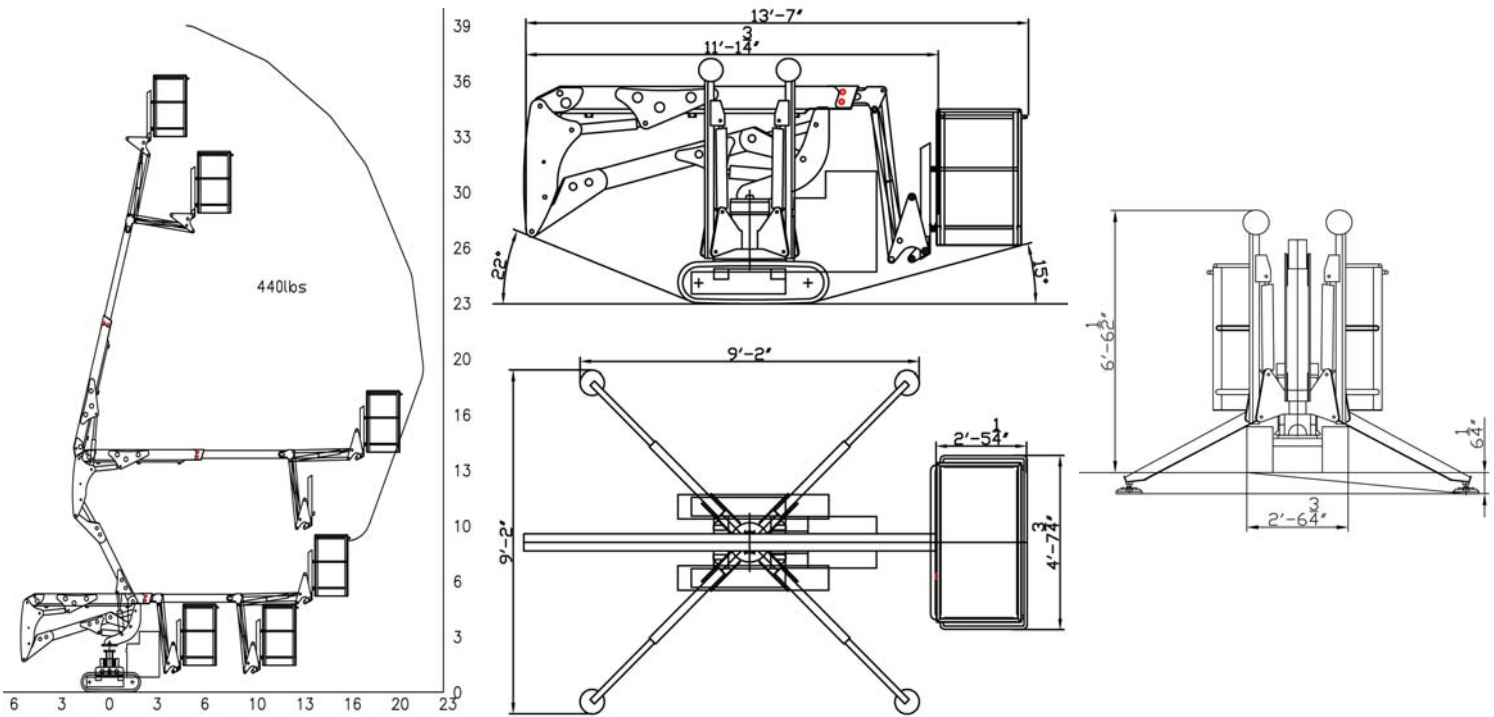

B39 BLUELIFT

Standard Equipment

- Automatic stability & outreach control
- Computer controlled (can-bus)
- Proportional control of all functions
- Self propelled
- 110V drive motor
- Honda single cylinder engine
- 360° non cont. turret rotation
- Manual pump for emergency lowering
- Width of only 2ft7in
- 2 person basket
- Full work height with 440lbs in basket
- Space for tools etc in basket
- 110V to the basket
- Remote control
- FMS (Function Memory System)
- Automatic turret center stop

Optional Equipment

- 180° (+/-90°) basket rotation
- Non marking tracks
- Air/water to the basket
- Hatz diesel engine
- Honda iGX440 15HP engine
- Wireless control

Additional Specifications

Boom angle	0°/ +75°
Oil tank capacity	8gal
Max windspeed	28mph
Operating speed	0.9mph
Travel speed	0.9mph
Drive gradability	15°/28%
Set-up gradability	5°/9%



SKAKO
LIFT

Skako Lift, Inc
1416D Stonehollow Dr.
Kingwood, TX 77339
TF: 1-866-358-7088
Tel: 281-358-7088
Fax: 281-359-3500
www.skakoliftusa.com