



## FLOOR DRAINS

### SUFFIX H - ADJUSTABLE STRAINER WITH ROUND SOLID HINGED COVER



**FUNCTION:** Used in areas where intermittent drain use is required. Solid cover prevents intrusion of chips, sawdust, etc., which are swept up before cover is opened for washdown. The secondary strainer prevents debris from entering the waste line.

<b>OPTIONS:</b>		<b>ADD</b>
-BFV	Ball Float Backwater Valve .....	230.00
-U	Vandal Proof Screws .....	33.00
-V	Flapper Backwater Valve.....	230.00

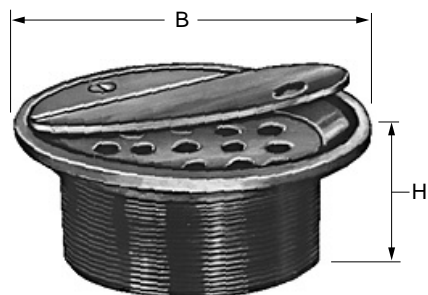

B TOP SIZE	H	PB TOP	†NB TOP	CP TOP	APPROX. WEIGHT LBS
05"	2"	377.00	411.00	449.00	4
06"	2"	404.00	469.00	517.00	5
07"	2 1/4"	641.00	730.00	804.00	6
08"	2 1/2"	675.00	740.00	817.00	7

**REGULARLY FURNISHED:** Adjustable Round Strainer with Hinged Solid Cover and Secondary Strainer.

### SUFFIX J - ADJUSTABLE STRAINER WITH ROUND SPANNER WRENCH COVER

**FUNCTION:** Solid gas tight, vandal proof, threaded cover for areas where intermittent drain use is required.

<b>OPTIONS:</b>		<b>ADD</b>
-BFV	Ball Float Backwater Valve .....	230.00
-SC	Smooth Cover .....	123.00
-SW	Spanner Wrench.....	84.00
-V	Flapper Backwater Valve.....	230.00

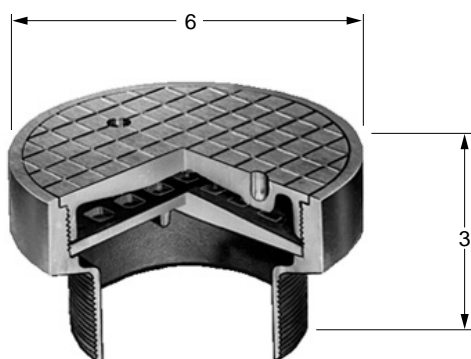

TOP SIZE	PB TOP	†NB TOP	CP TOP	APPROX. WEIGHT LBS
06"	525.00	571.00	629.00	6

**REGULARLY FURNISHED:**  
Adjustable Round Strainer with Spanner Wrench Cover and Secondary Strainer.

