



FLOOR DRAINS

FIG. 2143 HEAVY DUTY FLOOR DRAIN WITH 15" ROUND TOP W/TRACTOR GRATE



FUNCTION: Used in heavy traffic areas where waste water contains no sediment or debris and floor construction requires a shallow body. Large top area permits use where high flow is anticipated.

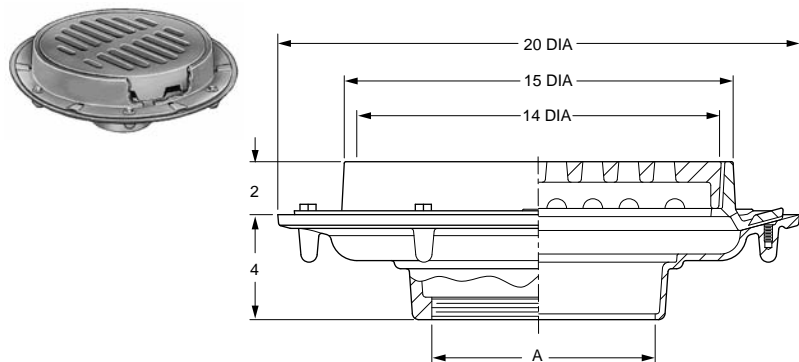

A OUTLET SIZE	TOP SIZE	FREE AREA SQ IN	†DUCO CI	DUCO CI PB TOP	DUCO CI NB TOP	APPROX. WEIGHT LBS
03, 04, 05"	15"	45	1,658.00	2,317.00	2,457.00	71
06, 08"	15"	45	1,658.00	2,317.00	2,457.00	73

REGULARLY FURNISHED: Duco Cast Iron Body and Flashing Collar with Cast Iron Tractor Grate.

OUTLET VARIATIONS (Specify type of outlet and pipe size in inches.)

Outlet Type	Outlet Designation Outlet Type/Pipe Size	Body HT. DIM.	ADD
Inside Caulk	C03, C04, C05, C06, C08	4"	N/C
Threaded	T03, T04, T05, T06, T08	4"	47.00
No-Hub			See Fig. 2646Y

OPTIONS:

		ADD
-D	Dome Grate, CI	244.00
-FBS	Alum Flat Bottom Strainer	59.00
-FBSCI	Flat Bottom Strainer, CI	58.00
-G	Galv CI Body	639.00
-HC4	4" High Collar	275.00
-M	Ductile Iron Grate	400.00
-S	Square Top, CI	286.00
-SNB	Square Top, add to CI	1,198.00
-SPB	Square Top, add to CI	1,036.00
-U	Vandal Proof Grate	89.00

FIG. 2145 HEAVY DUTY FLOOR DRAIN WITH 12" ROUND TOP W/TRACTOR GRATE

FUNCTION: Used in heavy traffic areas where waste water contains no sediment or debris and floor construction requires a shallow drain. Body flange and flashing collar serve as anchor in on-grade locations and as flashing clamp when installed in waterproof floors.

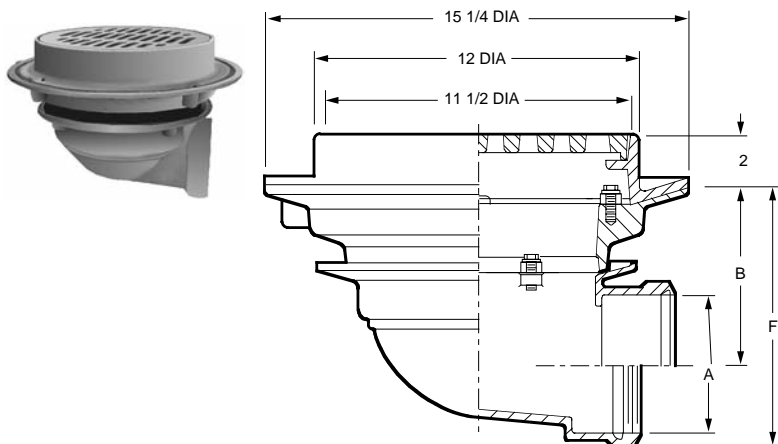

A OUTLET SIZE	TOP SIZE	FREE AREA SQ IN	B	†DUCO CI	DUCO CI PB TOP	DUCO CI NB TOP	APPROX. WEIGHT LBS
02"	12"	29	6 7/8	1,094.00	1,489.00	1,551.00	51
03"	12"	29	6 3/8	1,094.00	1,489.00	1,551.00	51
04"	12"	29	5 7/8	1,094.00	1,489.00	1,551.00	51
05"	12"	29	5	1,094.00	1,489.00	1,551.00	53
06"	12"	29	4 1/2	1,094.00	1,489.00	1,551.00	53

REGULARLY FURNISHED: Duco Cast Iron Body and Flashing Collar with Cast Iron Tractor Grate.

OUTLET VARIATIONS (Specify type of outlet and pipe size in inches.)

Outlet Type	Outlet Designation Outlet Type/Pipe Size	"F" Body HT. DIM.	ADD
Inside Caulk	C02	8 5/8"	N/C
	C03, C04	8 3/4"	N/C
	C05, C06	8 1/2"	N/C
Threaded	T02	8 5/8"	N/C
	T03, T04	8 3/4"	N/C
	T05, T06	8 1/2"	N/C
No-Hub	Y02	8 5/8"	N/C
	Y03, Y04	8 3/4"	N/C
	Y05, Y06		See Fig. 2646Y

OPTIONS:

		ADD
-ARI	ARC Inside	392.00
-ARIO	ARC In and Out	518.00
-B	Sediment Bucket	156.00
-DG	Deflector Grate	242.00
-G	Galvanized CI	444.00
-M	Ductile Iron Grate	157.00
-P	Trap Primer Conn	99.00
-S	Square Top, CI	208.00
-SC	Solid Scoriated Cover	354.00
-SNB	Square Top, add to CI	753.00
-SPB	Square Top, add to CI	654.00
-U	Vandal Proof Grate	89.00

