



FLOOR DRAINS

FIG. DX2005 (A) FLOOR OR SHOWER DRAIN AND ADJ. WIDE FLANGE STRAINER WITH ROUND GRATE
FIG. DX2010 (B) FLOOR OR SHOWER DRAIN AND ADJ. WIDE FLANGE STRAINER WITH SQUARE GRATE



FUNCTION: Used in any floor or shower area. Four inch wide flange allows ample surface adhesion of traffic bearing deck covering.

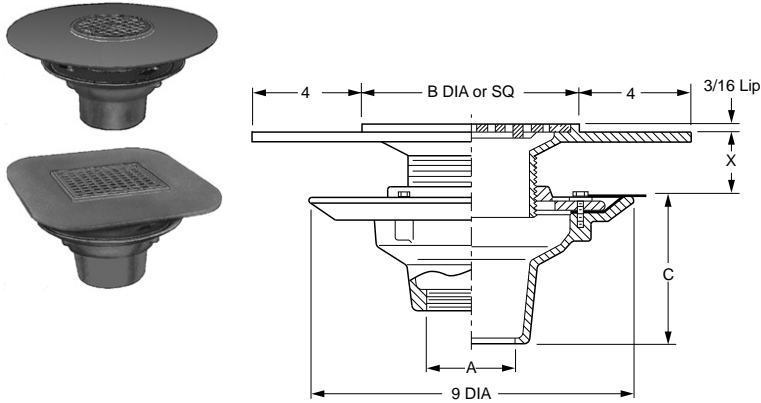

OUTLET VARIATIONS (Specify type of outlet and pipe size in inches.)

Outlet Type	Outlet Designation	Outlet Type/Pipe Size	"C" Body HT. DIM.	ADD
Inside Caulk (2010)	C02, C03, C04		4"	N/C
Speedi-Set SW (2005)	L02, L03, L04		4"	N/C
Speedi-Set XH (2005)	LXH02, LXH03, LXH04		4"	N/C
Threaded (2010)	T02, T03, T04		3"	47.00
No-Hub (2005)	Y02, Y03, Y04		4"	N/C

OPTIONS:

Option	Description	ADD
-ARI	Acid Resistant Inside	102.00
-BB	Bronze Body, 02-04"	734.00
	05-06"	2,255.00
-DID*	Drain Installation Device	83.00
-G	Galvanized Body	119.00
-LWH	Less Weep Holes	N/C
-P	Trap Primer Conn	N/C
-SH	Sec Holes in Flange	74.00
-U	Vandal Proof Screws	33.00

FLOOR DRAINS

A OUTLET SIZE	B STRAINER SIZE	X MIN	X MAX	PB TOP	†NB TOP	CP TOP	APPROX. WEIGHT LBS.
02, 03, 04"	05"	1 1/4	2	814.00	847.00	921.00	27
02, 03, 04"	06"	1 1/4	2	814.00	847.00	921.00	29

*Applies to 2005 only.

REGULARLY FURNISHED: Duco Cast Iron Body, Adjustable Strainer as Indicated by Suffix Letter Selected with 4" Wide Flange and Secondary Flashing Flange.

FIG. 2005(-D) FLOOR DRAIN AND ADJ. STRAINER WITH ROUND REINFORCED TRACTOR GRATE
FIG. 2010(-E) FLOOR DRAIN AND ADJ. STRAINER WITH ROUND REINFORCED TRACTOR GRATE

FUNCTION: Used in finished floors where medium weight wheeled loads are anticipated and loose set non-tilt tractor grate is desired.

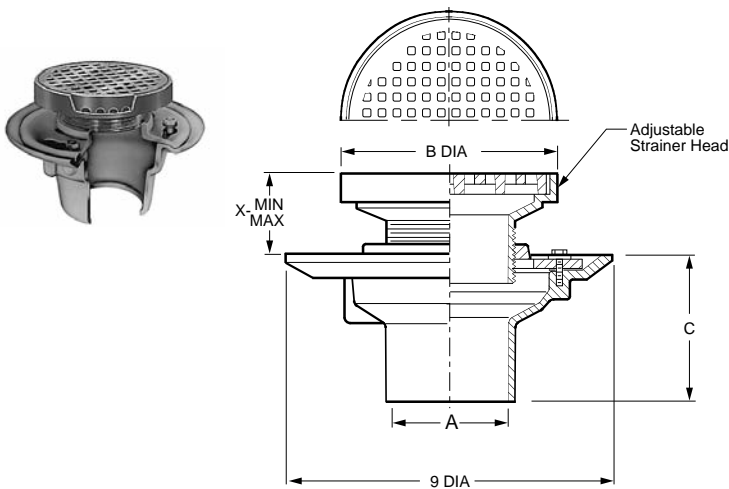

OUTLET VARIATIONS (Specify type of outlet and pipe size in inches.)

Outlet Type	Outlet Designation	Outlet Type/Pipe Size	"C" Body HT. DIM.	ADD
Inside Caulk (2010)	C02, C03, C04		4"	N/C
Speedi-Set SW (2005)	L02, L03, L04		4"	N/C
Speedi-Set XH (2005)	LXH02, LXH03, LXH04		4"	N/C
Threaded (2010)	T02, T03, T04		3"	47.00
No-Hub (2005)	Y02, Y03, Y04		4"	N/C

OPTIONS:

Option	Description	ADD
-ARI	Acid Resistant Inside	102.00
-B	Sediment Bucket	65.00
-BB	Bronze Body, 02-04"	734.00
	05-06"	2,255.00
-BFV	Ball Float Bkwtr Valve	230.00
-DID*	Drain Installation Device	83.00
-G	Galvanized CI Body	119.00
-P	Trap Primer Conn	N/C
-U	Vandal Proof Screws	33.00
-V	Backwater Valve	230.00

*Applies to 2005 only.

A OUTLET SIZE	STRAINER SUFFIX	B TOP SIZE	X MIN	X MAX	CI TOP	PB TOP	†NB TOP	CP TOP	APPROX. WEIGHT LBS.
02, 03, 04"	D	07"	2 1/4	3 1/4	328.00	622.00	678.00	734.00	14
02, 03, 04"	E	09"	2 3/4	3 1/2	403.00	872.00	942.00	1,025.00	6

REGULARLY FURNISHED: Duco Cast Iron Body and Flashing Collar, Adjustable Strainer Head as Indicated by Suffix Letter Selected. Medium Duty Tractor Grate.

When ordering, specify drain body and strainer type, size and finish. Ex. 2005Y04 w/A05NB.

