

MODEL A SINGLE-STAGE TWO STEP MODEL B TWO-STAGE, TWO-STEP FUEL UNITS AND MODEL B TWO-STAGE, HIGH-PRESSURE FUEL UNITS

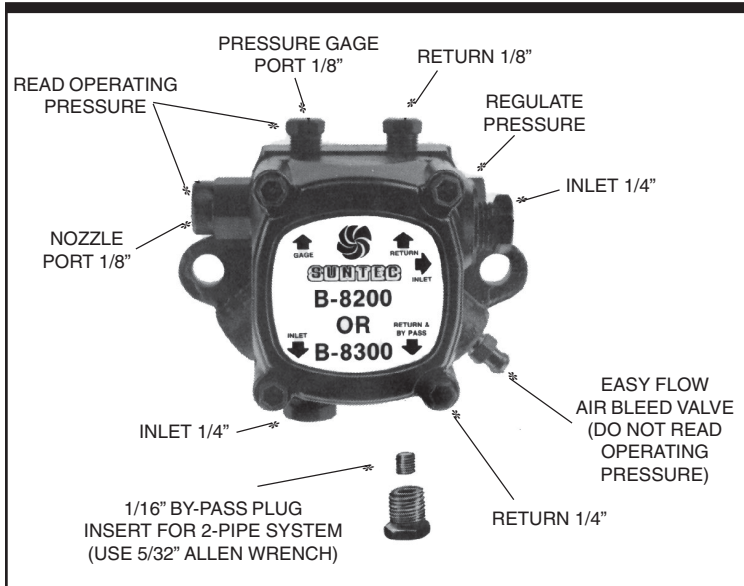

FIGURE 1

GENERAL INFORMATION • ALL SYSTEMS

IMPORTANT INFORMATION Long or oversized inlet lines may require the pump to operate dry during initial bleeding period. In such cases, the priming may be assisted by injecting fuel oil into the pump gearset. Under lift conditions, oil lines and fittings must be air tight. To assure this, "pipe dope" may be applied to both the used and unused inlet and both return fittings. **DO NOT USE TEFLON TAPE!! DO NOT USE COMPRESSION FITTINGS!!**

MOUNTING POSITION Model "A" Single-Stage Fuel Unit may be mounted in any position. Model "B" Two-Stage Fuel Unit may be mounted in any position except upside down (1/8" ports pointed down).

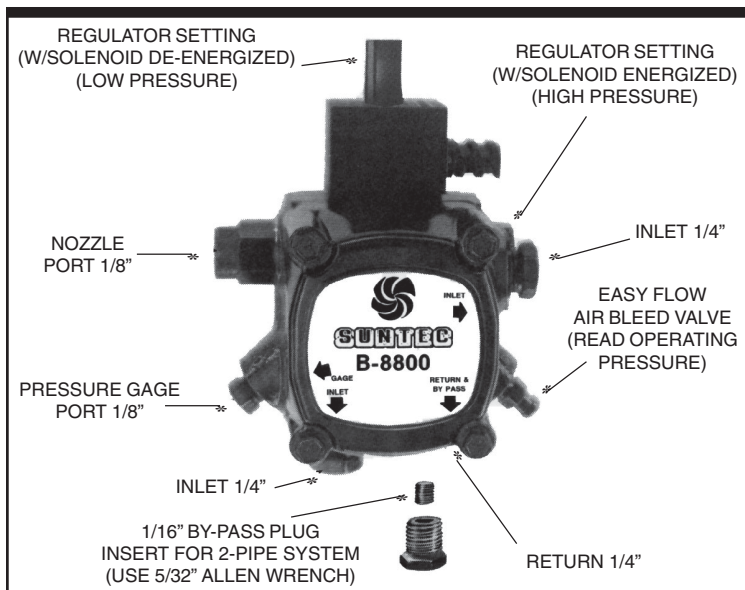

FIGURE 2

VACUUM CHECK A vacuum gage may be installed in either of the 1/4" inlet ports or in the 1/8" return port (on single-pipe installations), whichever is most convenient. The Model "A" pump should be used where the vacuum does not exceed 6" hg. single-pipe and 12" hg. two-pipe. The Model "B" should be used where vacuum does not exceed 17" hg. Running vacuum is the total of all pressure drops (ΔP) from the tank to the inlet of the pump.

CAUTION

Pressurized or gravity feed installations must not exceed 10 P.S.I. on inlet line or return line at the pump. A pressure greater than 10 P.S.I. may cause damage to the shaft seal.

TWO-STEP PUMPS • FIGURE 2

MODEL SHOWN IS RIGHT-HAND ROTATION; ALL PORTS ARE REVERSED FOR LEFT-HAND ROTATION.

SOLENOID WIRING Refer to burner manufacturer's manual for instructions.

REGULATOR SETTING Install pressure gage in gage port (remove after adjustment); proper nozzle in nozzle line.

- Low Fire -- With solenoid de-energized, adjust low-fire regulator to desired pressure. (Range 100 to 200 PSI)
- High Fire -- With solenoid energized, adjust high-fire regulator to desired pressure. (Range 200 to 300 PSI)

NOTE: EXTERNAL CUTOFF VALVE IS REQUIRED.

ONE-PIPE SYSTEM • FIGURE 3

DO NOT INSTALL BY-PASS PLUG! Connect inlet line to pump inlet. Start burner. Arrange primary burner control for continuous operation during purging. Open easy flow bleed valve 1 turn CCW. Bleed unit until all air bubbles disappear -- **HURRIED BLEEDING WILL IMPAIR EFFICIENT OPERATION OF UNIT.** Tighten easy flow bleed valve securely. For additional information, see Single-Pipe Installation Section, page III-1 of this manual.

ONE-PIPE SYSTEM • MODEL A

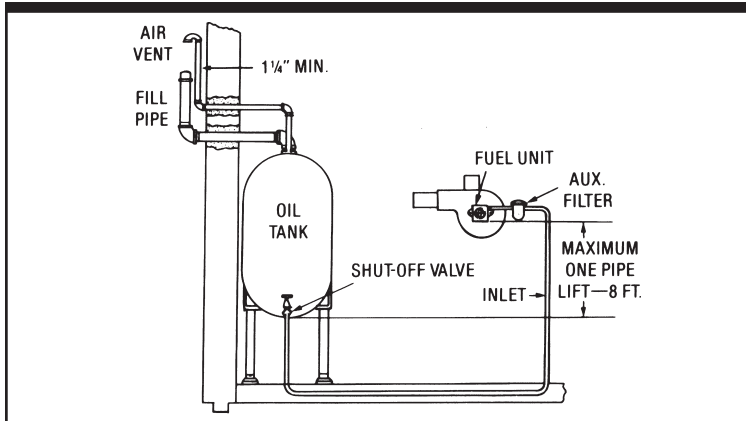

FIGURE 3

The SUNTEC MODEL "A"-70 FUEL UNIT may be installed ONE-PIPE with gravity feed or lift.

The maximum allowable lift is 8 ft. -- see Figure 3.

IMPORTANT: One-pipe installations must be absolutely airtight or leaks or loss of prime may result. Bleed line and fuel unit completely. **Bleed for 15 seconds after last air is seen from easy-flow to be certain lines are air free.**

L=Line Length in Feet	H=Head in Feet	Q=Firing Rate in GPH
$\frac{3}{8}$ " Line $L = \frac{6 \cdot 75H}{.0086 Q}$	$\frac{1}{2}$ " Line $L = \frac{6 \cdot 75H}{.00218 Q}$	

If tank is above pump, change - to +. Fittings, valves, and filters will reduce total length allowed.

TWO-PIPE SYSTEM • FIGURE 4

REMOVE 1/16" BY-PASS PLUG FROM PLASTIC BAG ATTACHED TO UNIT. Remove 1/4" plug from return port. Insert by-pass plug (see Figure 1 or 2), tighten plug. Attach return and inlet lines. Start burner -- air bleeding is automatic. Opening easy flow air bleed valve will allow a faster bleed if desired. Return line must terminate 3-4" above supply line inlet (see Figure 4). Failure to do this may introduce air into the system and could result in loss of prime.

For additional information, see Two-Pipe Installation Section, page III-3 of this manual.

TWO-PIPE SYSTEM • MODEL A AND B

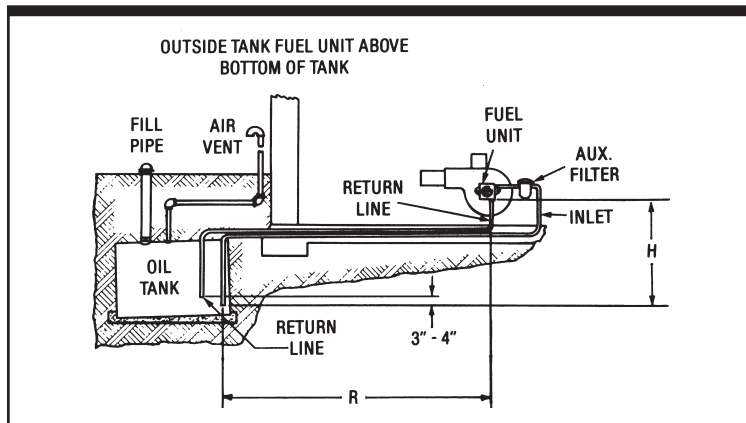

FIGURE 4

Always terminate return line as shown in Figure 4. Line lengths include both vertical and horizontal lengths.

ALL INSTALLATIONS SHOULD BE MADE IN ACCORDANCE WITH LOCAL AND NATIONAL CODES.