



INTERCEPTORS

FIG. 8300GT SER. STEEL GREASE INTERCEPTORS W/SEMI-AUTOMATIC DRAW-OFF & RECEIVING CRADLE



FUNCTION: The all steel receiving cradle provides positive support for the interceptor and vertical adjustability for the inlet and outlet connections to meet the drainage piping. The receiving cradle can be set in the slab at the time of pouring or set in a pre-sleeved opening in the rough slab. The cradle is secured and suspended in the rough slab by its anchoring flange. The semi-automatic draw-off type grease interceptor is lowered into the receiver cradle and adjusted to the elevation of the drainage piping. The interceptor, line shut-off valve and flexible grease draw-off hose are readily accessible for cleaning and inspection simply by removing the cradle cover which sits flush with the floor. The cradle supports the interceptor and has no provisions for waterproofing the interceptor in relation to the cradle and ceiling below.

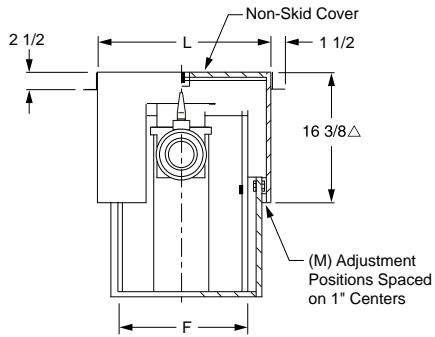

Front View

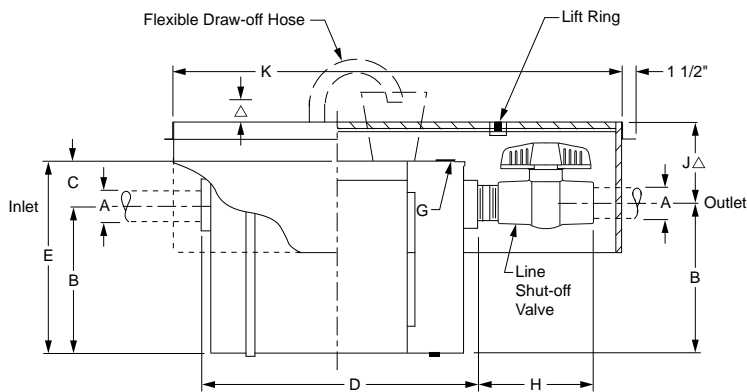

Side View
Fig. 8335GT Shown

Δ NOTE: When tile top is specified, add 1". When Terrazzo top is specified, add 1 1/4".

FIGURE NO.	GPM FLOW RATE	GREASE CAP. LBS.	INLET & OUTLET SIZE A*	ROUGHING DIM			BODY		C.O. PLUG SIZE G	LINE SHUT-OFF VALVE H	CRADLE DIM				†DUCO COAT INSIDE AND OUTSIDE	INTERC. *▲w/ARC IN OR OUT -ARI	INTERC. *▲w/ARC IN AND OUT -ARIO	ADD FOR:		APPROX. WT. LBS.	
				B	C	D	E HEIGHT	F WIDTH			J Δ MIN	MAX	**K LENGTH	L WIDTH				M	▲ -ARC (CRADLE)		DRIP PAN (-W)
8307GT	7	14	02"	8 1/2"	3 1/2"	19"	12"	10 3/4"	2"	6 3/4"	8"	19"	38 1/4"	19 1/4"	12"	10,100.00	12,842.00	15,322.00	2,143.00	1,012.00	180
8310GT	10	20	02"	9 1/2"	3 3/4"	21 1/4"	13 1/4"	13"	2"	6 3/4"	7"	18"	38 1/4"	19 1/4"	12"	11,847.00	14,644.00	17,176.00	2,143.00	1,034.00	215
8315GT	15	30	02"	12"	3 1/2"	25"	15 1/2"	14"	2"	6 3/4"	8 1/2"	20 1/2"	42 3/4"	22 3/4"	13"	12,864.00	16,093.00	18,783.00	2,143.00	1,158.00	245
8320GT	20	40	03"	13"	4"	28 1/2"	17"	15 3/4"	2"	10"	7 1/2"	19 1/2"	42 3/4"	22 3/4"	13"	14,973.00	18,724.00	21,678.00	2,143.00	1,308.00	312
8325GT	25	50	03"	15 1/4"	4 1/2"	30"	19 3/4"	16 3/4"	2"	10"	9 1/2"	21 1/2"	47 3/4"	25 3/4"	13"	16,531.00	20,432.00	23,593.00	3,096.00	1,480.00	386
8335GT	35	70	03"	16"	5"	32 1/2"	21"	18 1/4"	2"	10"	8 3/4"	20 3/4"	47 3/4"	25 3/4"	13"	17,220.00	21,261.00	24,630.00	3,096.00	1,608.00	325
8350GT	50	100	03"	17 1/2"	6 3/4"	35 1/2"	24 1/4"	20 3/4"	2"	10"	10 1/4"	19 1/4"	50 3/4"	28 1/4"	13"	18,808.00	23,051.00	26,722.00	3,096.00	1,822.00	362
8375GT	75	150	04"	21 1/2"	15 1/2"	50"	37"	30 1/2"	3"	12 3/4"	16"	25"	66 1/2"	38 1/4"	13"	22,539.00	26,216.00	31,041.00	3,096.00	2,342.00	419

*Acid Resistant Coating on Interceptor only

**When specifying a larger Inlet & Outlet size, the "K" dimension must be increased.

▲ When Acid Resistant Coating on Cradle is needed, -ARC must also be specified.

REGULARLY FURNISHED: Fabricated Steel Interceptor and Receiving Cradle with Gray Duco Coating Inside and Outside with Steel Cone, Flexible Draw-off Hose and Cap, Line Shut-off Valve and Flow Control Fitting.

