



# INTERCEPTORS

## FIG. 8925 SERIES SEDIMENT/OIL INTERCEPTOR



**FUNCTION:** Used in service stations, parking garages, car and truck washes and industrial plants where discharged water contains oily sediment and sludge. The sediment and sludge are collected in the sediment pan and removable bucket. The oily residue is trapped in the interceptor and can be skimmed off periodically.

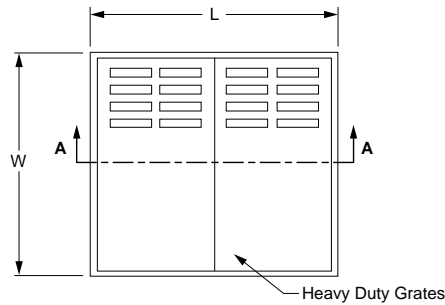

**Top View**

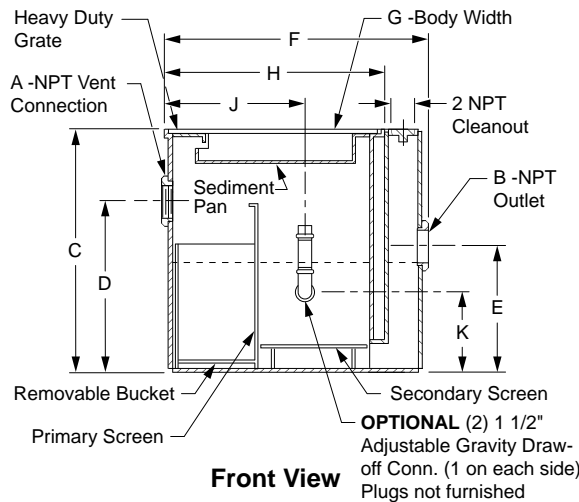

**Front View**

**OPTIONS:**

- OD Oil Draw-off Assembly .....264.00
- SS Stainless Steel Body .....POA

**ADD**

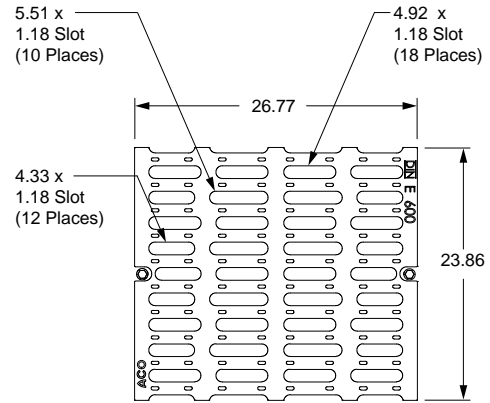

**H20 Ductile Iron Grate Detail\*\***

- NOTE:** Interceptor shall be vented on outlet side per local code requirements
- NOTE:** It is the responsibility of the installer to check all parts (internal and external) to verify they are in their proper operating order and location.
- \*\*NOTE:** When specifying H20 Ductile Iron Slotted Grate, the length and width dimensions may vary when using this Grate.

**INTERCEPTORS**

FIGURE NO.	SLUDGE CAP LBS	A VENT SIZE	B OUTLET SIZE	C	D	E	F	G	H	J	K	NO. OF 12" X 24" GRATES	†STEEL DUCO COATED	ADD FOR:				APPROX. WEIGHT LBS.	
														ARC IN AND OUT (-ARIO)	EXT. (-E) UP TO 6"	EXT. PER INCH OVER 6"	ANCHOR FLANGE (-F)		FLANGE AND FLASHING CLAMP (-FC)
8925-12	12	02"	02"	18"	13"	10 1/2"	17 1/2"	12 1/2"	12 1/2"	9"	6"	*1	2,311.00	481.00	386.00	58.00	481.00	663.00	75
8925-60	60	02"	04"	26"	20"	18"	29 1/2"	12 1/2"	24 1/2"	19"	8"	1	6,235.00	579.00	579.00	87.00	663.00	1,000.00	175
8925-100	100	02"	04"	34"	27"	22"	29 1/2"	24 1/2"	24 1/2"	19"	12"	2	8,858.00	915.00	767.00	124.00	835.00	1,261.00	280
8925-200	200	02"	04"	34"	27"	22"	41 1/2"	24 1/2"	36 1/2"	27"	12"	3	13,128.00	1,923.00	1,154.00	182.00	1,100.00	1,620.00	370

\*Grate is 12 x 12"

**REGULARLY FURNISHED:** Fabricated Steel Body with Duco Coating and Sediment Pan w/Stainless Steel Bucket w/Perforated Back, Secondary Screen and Heavy Duty Cast Iron Grating.

