



FLOOR DRAINS



FIG. 2250 LARGE CAPACITY HEAVY DUTY FLOOR DRAIN WITH 15" TOP W/TRACTOR GRATE AND SLOTTED SEDIMENT BUCKET

FUNCTION: For use in areas where heavy traffic occurs and water contains sediment and debris that must be intercepted. Large free area of top grate and deep sump handles large volume of water. Particularly suited for parking areas and playgrounds.

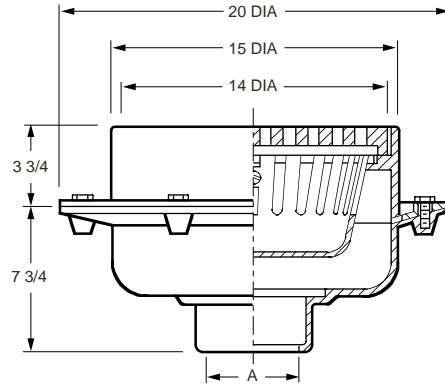

A OUTLET SIZE	TOP SIZE	FREE AREA SQ IN	†DUCO CI	DUCO CI PB TOP	DUCO CI NB TOP	APPROX. WEIGHT LBS
04, 05"	15"	45	1,782.00	3,212.00	3,396.00	110
06, 08"	15"	45	1,782.00	3,212.00	3,396.00	112

REGULARLY FURNISHED: Duco Cast Iron Body and Flashing Collar with Cast Iron Tractor Grate and Slotted Sediment Bucket.

OUTLET VARIATIONS (Specify type of outlet and pipe size in inches.)

Outlet Type	Outlet Designation Outlet Type/Pipe Size	Body HT DIM	ADD
Inside Caulk	C04, C05, C06, C08	7 3/4	N/C
Threaded	T04, T05, T06, T08	7 3/4	47.00

OPTIONS:

Option	Description	ADD
-BS	Bucket w/Mesh Screen	465.00
-D	Dome Grate, CI	244.00
-DNB	Dome Grate, add to CI	2,349.00
-DPB	Dome Grate, add to CI	2,043.00
-G	Galvanized CI	1,195.00
-HC	2" High Collar	N/C
-M	Ductile Iron Grate	400.00
-S	Square Top, CI	286.00
-SNB	Square Top, add to CI	2,014.00
-SPB	Square Top, add to CI	1,808.00
-U	Vandal Proof Grate	124.00

FLOOR DRAINS

FIG. 2253 LARGE CAPACITY HEAVY DUTY FLOOR DRAIN WITH 15" TOP W/TRACTOR GRATE AND SLOTTED SEDIMENT BUCKET

FUNCTION: For use in areas where heavy traffic occurs and water contains sediment and debris that must be intercepted. Large free area of top grate and deep sump handles large volume of water. Particularly suited for parking areas and playgrounds.

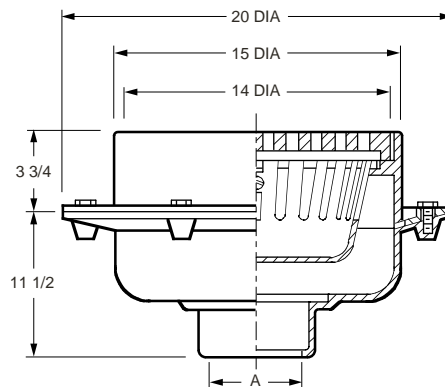

A OUTLET SIZE	TOP SIZE	FREE AREA SQ IN	†DUCO CI	DUCO CI PB TOP	DUCO CI NB TOP	APPROX. WEIGHT LBS
04, 05"	15"	45	2,030.00	3,460.00	3,644.00	110
06"	15"	45	2,030.00	3,460.00	3,644.00	112

REGULARLY FURNISHED: Duco Cast Iron Body and Flashing Collar with Cast Iron Tractor Grate and Slotted Sediment Bucket.

OUTLET VARIATIONS (Specify type of outlet and pipe size in inches.)

Outlet Type	Outlet Designation Outlet Type/Pipe Size	Body HT DIM	ADD
Inside Caulk	C04, C05, C06	11 1/2	N/C
Threaded	T04, T05, T06	11 1/2	47.00

OPTIONS:

Option	Description	ADD
-BS	Bucket w/Mesh Screen	465.00
-D	Dome Grate, CI	244.00
-DNB	Dome Grate, add to CI	2,349.00
-DPB	Dome Grate, add to CI	2,043.00
-FBSCI	Flat Bottom Strainer	58.00
-G	Galvanized CI	1,195.00
-HC	2" High Collar	N/C
-M	Ductile Iron Grate	400.00
-S	Square Top, CI	286.00
-SNB	Square Top, add to CI	2,014.00
-SPB	Square Top, add to CI	1,808.00
-U	Vandal Proof Grate	124.00

