



FLOOR DRAINS



FIG. 2255 LARGE CAPACITY HEAVY DUTY FLOOR DRAIN WITH 15" TOP W/TRACTOR GRATE AND SLOTTED SEDIMENT BUCKET

FUNCTION: For use in areas where heavy traffic occurs and water contains sediment and debris that must be intercepted. Large free area of top grate and deep sump handles large volume of water. Particularly suited for parking areas and playgrounds.

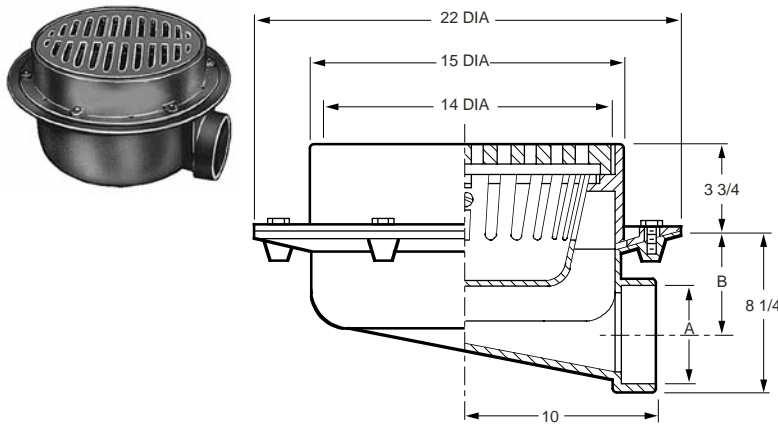

OUTLET VARIATIONS (Specify type of outlet and pipe size in inches.)

Outlet Type	Outlet Designation Outlet Type/Pipe Size	ADD
Inside Caulk OnlyC05, C06N/C

OPTIONS:

Option	Description	ADD
-BS	Bucket w/Mesh Screen465.00
-D	Dome Grate, CI244.00
-DNB	Dome Grate, add to CI2,349.00
-DPB	Dome Grate, add to CI2,043.00
-G	Galvanized CI1,195.00
-HC	2" High CollarN/C
-M	Ductile Iron Grate400.00
-S	Square Top, CI286.00
-SNB	Square Top, add to CI2,014.00
-SPB	Square Top, add to CI1,808.00
-U	Vandal Proof Grate124.00

A OUTLET SIZE	TOP SIZE	FREE AREA SQ IN	B	†DUCO CI	DUCO CI PB TOP	DUCO CI NB TOP	APPROX. WEIGHT LBS
05"	15"	45	4 7/8"	2,187.00	3,617.00	3,801.00	110
06"	15"	45	4 3/8"	2,187.00	3,617.00	3,801.00	112

REGULARLY FURNISHED: Duco Cast Iron Body and Flashing Collar with Cast Iron Tractor Grate and Slotted Sediment Bucket.

FIG. 2270 SMALL AREA MEDIUM DUTY FLOOR DRAIN WITH 8 1/2" ROUND TOP W/BAR GRATE

FUNCTION: Used in areas with moderate traffic and where waste water contains no sediment or debris and construction requires a shallow body drain for on-grade applications.

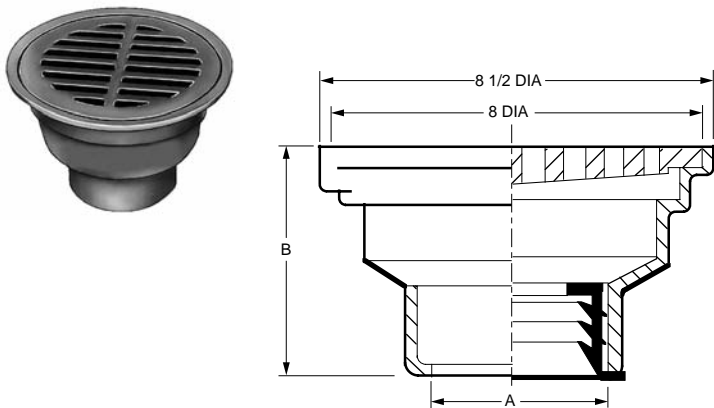

OUTLET VARIATIONS (Specify type of outlet and pipe size in inches.)

Outlet Type	Outlet Designation Outlet Type/Pipe Size	"B" Body HT. DIM.	ADD
Inside CaulkC02, C03, C045"N/C
Speedi-Set SWL02, L03, L045"N/C
Speedi-Set XHLXH02, LXH03, LXH045"N/C
ThreadedT02, T03, T043 1/2"47.00
No-HubY02, Y03, Y045"N/C

OPTIONS:

Option	Description	ADD
-AB	Sediment Bucket, Alum138.00
-B	Sediment Bucket, CI84.00
-D	Dome Grate, CI50.00
-DNB	Dome Grate, add to CI554.00
-DPB	Dome Grate, add to CI441.00
-FBSCI	Flat Bottom Strainer36.00
-G	Galvanized CI259.00
-H	Hinged Grate156.00
-M	Ductile Iron Grate128.00
-P	Trap Primer Conn.99.00
-S	Square Top, CI196.00
-SNB	Square Top, add to CI571.00
-SPB	Square Top, add to CI472.00
-TG	Tractor Grate (Spec Fig. 2271)84.00
-U	Vandal Proof Grate89.00
-XP	Closure Plug, 02, 03" 04"238.00400.00

A OUTLET SIZE	TOP SIZE	FREE AREA SQ IN	†DUCO CI	DUCO CI PB TOP	DUCO CI NB TOP	APPROX. WEIGHT LBS
02, 03, 04"	8 1/2"	14.25	197.00	463.00	526.00	13

REGULARLY FURNISHED: Duco Cast Iron Body and Loose Set Bar Grate.

