



ROOF DRAINS

FIG. 1460 MEDIUM - 11" SQUARE PROMENADE DECK DRAIN



FUNCTION: Medium size deck drain for use in flat roof decks. Body and accessories are compatible for installation in all types of roof construction. Square medium size top fits in with "block" patterns. This drain should only be used in areas of moderate flow requirements.

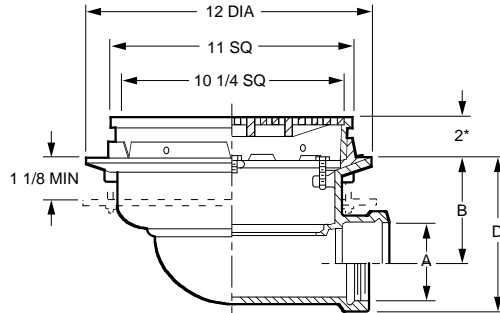

A OUTLET SIZE	TOP SIZE	B	FREE AREA SQ IN	†DUCO CI	DUCO CI PB TOP	DUCO CI NB TOP	APPROX. WEIGHT LBS
02"	11"	4 1/2"	31	767.00	1,158.00	1,218.00	51
03"	11"	4"	31	767.00	1,158.00	1,218.00	51
04"	11"	3 1/2"	31	767.00	1,158.00	1,218.00	51

REGULARLY FURNISHED: Duco Cast Iron Body and Flashing Clamp with Seepage Openings and Secured Square Hole Light Duty Grate.

OUTLET VARIATIONS (Specify type of outlet and pipe size in inches.)

Outlet Type	Outlet Designation Outlet Type/Pipe Size	D Body HT. DIM.	ADD
Inside Caulk	C02	6 1/2"	N/C
	C03, C04	6 5/8"	N/C
Threaded	T02	6 1/2"	N/C
	T03, T04	6 5/8"	N/C
No-Hub	Y02	6 1/2"	N/C
	Y03, Y04	6 5/8"	N/C

OPTIONS:

OPTION	DESCRIPTION	ADD
-C	Underdeck Clamp	90.00
-C2	Sec. Flash. Clamp	112.00
-E	Extension, per inch to 4"	52.00
-E04P	4" Perf SS Extension	383.00
-G	Galvanized Cast Iron	304.00
-HP	Heelproof Grate	N/C
-M	Ductile Iron Grate	330.00
-R	Sump Receiver	156.00
-U	Vandal Proof Grate	89.00

NOTE: Floor drains or area drains used to drain areas subject to rainfall should have an open area equal to twice the cross sectional area of the connecting pipe.

*Add 3/16" when bronze top is specified.

FIG. 1470 SMALL - 8" SQUARE PROMENADE DECK DRAIN

FUNCTION: For use in small roof areas which are designed for promenade or recreational purposes. Square top design is compatible with "block" patterns. This drain should be used for small roof areas only and where light rainfall is expected.

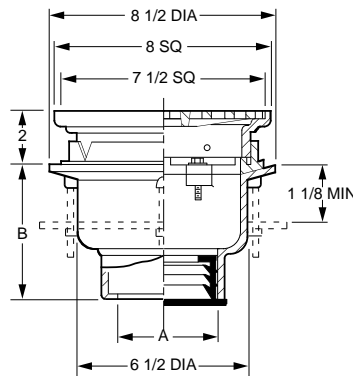

A OUTLET SIZE	TOP SIZE	FREE AREA SQ IN	†DUCO CI	DUCO CI PB TOP	DUCO CI NB TOP	APPROX. WEIGHT LBS
02, 03, 04"	8"	19	499.00	730.00	760.00	21

REGULARLY FURNISHED: Duco Cast Iron Body and Flashing Clamp with Seepage Openings and Secured Square Hole Light Duty Grate.

OUTLET VARIATIONS (Specify type of outlet and pipe size in inches.)

Outlet Type	Outlet Designation Outlet Type/Pipe Size	"B" Body HT. DIM.	ADD	
Inside Caulk	C02, C03, C04	5 1/2"	N/C	
	Speedi-Set SW	L02, L03, L04	5 1/2"	N/C
	Speedi-Set XH	LXH02, LXH03, LXH04	5 1/2"	N/C
Threaded	T02, T03, T04	4 1/4"	47.00	
No-Hub	Y02, Y03, Y04	5 1/2"	N/C	

OPTIONS:

OPTION	DESCRIPTION	ADD
-B	Sediment Bucket	128.00
-C	Underdeck Clamp	90.00
-C2	Sec. Flash. Clamp	112.00
-E	Extension, per inch to 4"	52.00
-E04P	4" Perf SS Extension	383.00
-G	Galvanized Cast Iron	164.00
-HP	Heelproof Grate	N/C
-M	Ductile Iron Grate	290.00
-R	Sump Receiver	156.00
-U	Vandal Proof Grate	89.00

NOTE: Floor drains or area drains used to drain areas subject to rainfall should have an open area equal to twice the cross sectional area of the connecting pipe.

