



CLEANOUTS

FIG. 4420, 4422 SERIES CAULK FERRULE CLEANOUT TAPER THREAD PLUG W/ROUND ACCESS COVER



FUNCTION: Used in hub openings in drainage piping where a cleanout is required. Ribbing on outside of ferrule prevents turning of ferrule in the caulking lead. Face-of-wall cover is desirable on finished walls.

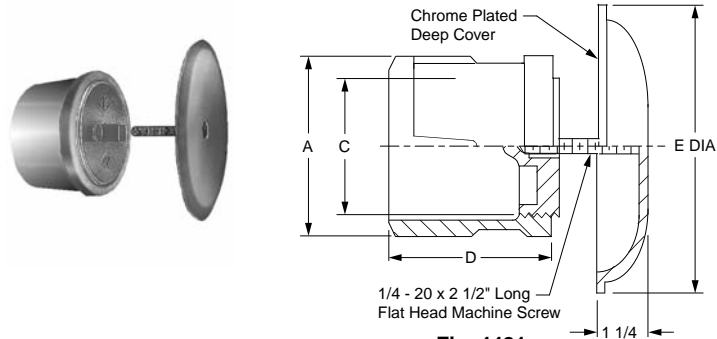

Fig. 4421

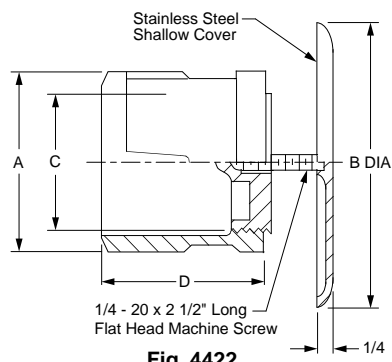

Fig. 4422

OPTIONS:

-LSS	6" Long Center Screw.....	28.00
-TP	"T" Handle for Plug.....	47.00
-U	Vandal Proof Screw.....	58.00

ADD

LESS COVER	PLUG MATERIAL		A - PIPE SIZE:	Δ02"	Δ03"	Δ04"	05"	06"	08"
4420CI	CI Ferrule and Brz Plug			58.00	90.00	124.00	187.00	256.00	474.00
4420BRZ	All Bronze			POA	POA	POA	POA	POA	POA
WITH COVER	PLUG MATERIAL	COVER MATERIAL	A - PIPE SIZE: B - COVER SIZE DIA:	Δ02"	Δ03"	Δ04"	05"	06"	08"
4422	CI Ferrule and Brz Plug	†Stainless Steel (-SS)		141.00	174.00	208.00	292.00	443.00	765.00
		Prime Coated Steel (-PC)		115.00	148.00	182.00	266.00	417.00	739.00
		Polished Bronze (-PB)		115.00	148.00	182.00	266.00	417.00	739.00
			C - SIZE	1 1/2"	2 1/2"	3 1/2"	4"	5"	6"
			D	3 1/2"	3 3/4"	4 1/4"	4 1/4"	4 1/4"	4 1/2"
			E DIA	*7 1/4"	*7 1/4"	*7 1/4"	*7 1/4"	9 1/4"	11 1/4"
			APPROX WT. LBS.	5	8	13	16	21	26

ΔSized for Service Weight and/or NO-HUB

*Die Formed SS Cover Only

REGULARLY FURNISHED: Duco Cast Iron Caulk Ferrule with Cast Bronze Taper Thread Plug with SS Round Cover and Screws. Type of Cover as Indicated by Figure Number Selected.

