



SPECIALTIES, STAINLESS AND CARBON STEEL

FIG. 9775, 9776 WALL CLEANOUTS



FUNCTION: Used in female NPT openings in drainage piping where a cleanout is required. Face-of-wall cover is desirable on finished walls.

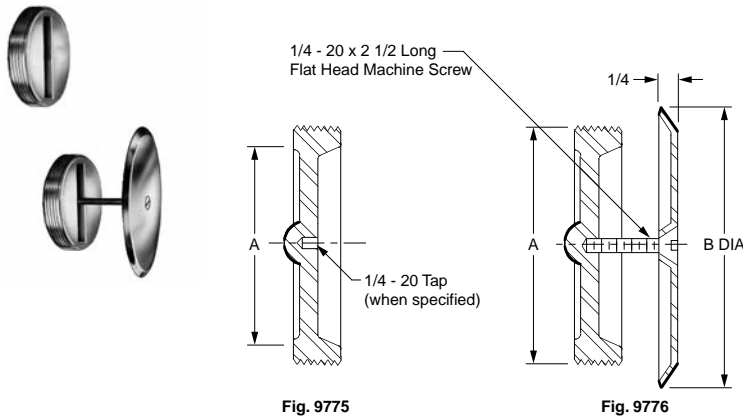

OUTLET VARIATIONS (Specify type of outlet and pipe size in inches.)

Outlet Type	Outlet Designation Outlet Type/Pipe Size	ADD
Threaded.....	T03, T04	POA

OPTIONS:

		ADD
-LS	6" Long Center Screw (Fig 9776)	POA
-TP	Plug Tapped 1/4-20 Thread (Fig 9775)	POA
-U	Vandal Proof Screws (Fig 9776).....	POA

FIGURE NO.	A OUTLET SIZE	B DIA COVER SIZE	†-CF8 (304) STAINLESS STEEL	-CF8M (316) STAINLESS STEEL	-A27 CARBON STEEL	APPROX. WT. LBS
9775	03"	-	POA	POA	POA	3
	04"	-	POA	POA	POA	5
9776	03"	5 1/2"	POA	-	-	3
	04"	7 1/4"	POA	-	-	5

REGULARLY FURNISHED: CF8 (Equivalent to Type 304) Rough Finish Stainless Steel Plug. Screw with Polished Stainless Steel Cover Plate as Indicated by Figure number.

FIG. 9780 LARGE GENERAL PURPOSE ROOF DRAIN

FUNCTION: Used in flat roofs of any construction. Large low profile dome provides sufficient free area for quick drainage of rain water and protects the drain sump and connected piping from the intrusion of debris. Wide clamping surface holds flashing and roofing materials without puncturing.

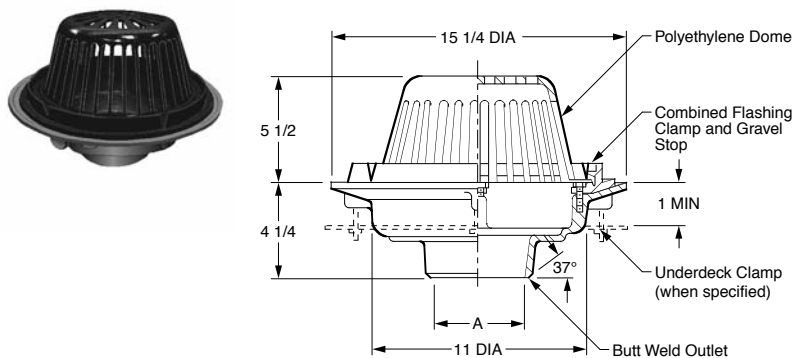

OUTLET VARIATIONS (Specify type of outlet and pipe size in inches.)

Outlet Type	Outlet Designation Outlet Type/Pipe Size	ADD
Butt Weld	BW03, BW04, BW06	POA
	Specify Schedule 5, 10, †40, or 80	

OPTIONS:

		ADD
-A27D	Carbon Steel Dome.....	POA
-C	Underdeck Clamp	POA
-CID	Cast Iron Dome	POA
-SD	Secured Dome	POA
-U	Vandal Proof	POA
-304D	Type 304 Steel Dome	POA
-316D	Type 316 Steel Dome	POA

A OUTLET SIZE	FREE AREA SQ IN	†-CF8 (304) SS BODY, COLLAR POLY DOME	-CF8M (316) SS BODY, COLLAR POLY DOME	-A27 STL BODY, COLLAR POLY DOME	APPROX. WT. LBS
03, 04"	102.5	POA	POA	POA	35
06"	102.5	POA	POA	POA	37

REGULARLY FURNISHED: CF8 (Equivalent to Type 304) Rough Finish Stainless Steel Body. Combined Flashing Collar and Gravel Stop and Polyethylene Dome.

FOR INFORMATION ON POA ITEMS, PLEASE CONTACT YOUR LOCAL JAY R. SMITH REPRESENTATIVE

