



FLOOR DRAINS



FIG. 2005 (-A) FLOOR DRAIN WITH ADJ. ROUND STRAINER
FIG. 2010 (-A) FLOOR DRAIN WITH ADJ. ROUND STRAINER

FUNCTION: General service floor drain for use in showers, toilets, kitchens and other finished areas where foot traffic is expected. The round top strainer head is used for all types of poured finished floors. Reversible flashing collar permits adjustment of the strainer to meet finished floor level.

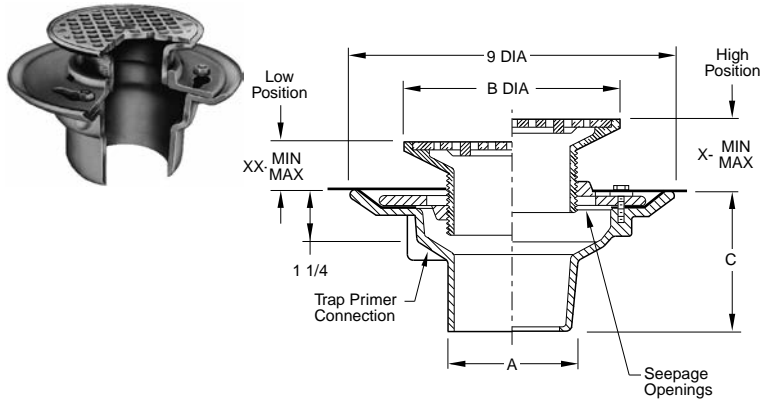

OUTLET VARIATIONS (Specify type of outlet and pipe size in inches.)

Outlet Type	Outlet Designation	Outlet Type/Pipe Size	"C" Body HT. DIM.	ADD
Inside Caulk (2010)	C02, C03, C04		4"	N/C
Speedi-Set SW (2005)	L02, L03, L04		4"	N/C
Speedi-Set XH (2005)	LXH02, LXH03, LXH04		4"	N/C
Threaded(2010)	T02, T03, T04		3"	47.00
No-Hub (2005)	Y02, Y03, Y04		4"	N/C

OPTIONS:

Option	Description	ADD
-ARI	Acid Resistant Inside	102.00
-B	Sediment Bucket	65.00
-BB	Bronze Body, 02-04" 05-06"	734.00 2,255.00
-BFV	Ball Float Bkwtr Valve	230.00
-DID*	Drain Installation Device	83.00
-G	Galvanized Body	119.00
-H	Hinged Grate (6, 7, 8")	168.00
-P	Trap Primer Conn	N/C
-U	Vandal Proof Screws	33.00
-V	Flapper Backwater Valve	230.00

A OUTLET SIZE	B TOP SIZE	X MIN MAX	XX MIN MAX	PB TOP	†NB TOP	CP TOP	APPROX. WEIGHT LBS.
02, 03, 04"	05"	1 1/4 2 1/4	3/4 1 5/8	279.00	294.00	311.00	12
02, 03, 04"	06"	1 1/4 2 1/4	3/4 1 5/8	324.00	359.00	382.00	13
02, 03, 04"	07"	1 1/4 2 1/4	7/8 1 7/8	393.00	413.00	443.00	14
02, 03, 04"	08"	1 1/2 2 1/2	1 1 7/8	491.00	519.00	561.00	15
02, 03, 04"	09"	1 1/2 2 3/8	1 1 7/8	671.00	708.00	767.00	18
02, 03, 04"	10"	1 1/2 2 3/8	1 1 7/8	671.00	708.00	767.00	21

*Applies to 2005 only.

REGULARLY FURNISHED: Duco Cast Iron Body with Flashing Collar and Adjustable Round Strainer Head.

FIG. 2005 (-B) FLOOR DRAIN WITH ADJ. SQUARE STRAINER
FIG. 2010 (-B) FLOOR DRAIN WITH ADJ. SQUARE STRAINER

FUNCTION: General service floor drain for use in showers, toilets, kitchens and other finished areas where foot traffic is expected. The square top is particularly adaptable to floors that are finished in material of square or straight line pattern. Reversible flashing collar permits adjustment of the strainer to meet finished floor level.

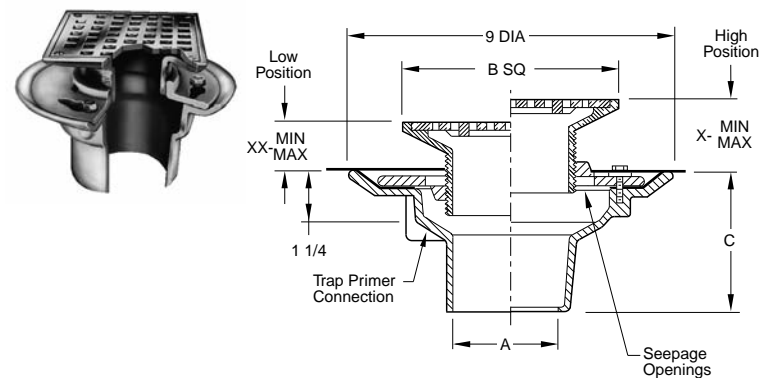

OUTLET VARIATIONS (Specify type of outlet and pipe size in inches.)

Outlet Type	Outlet Designation	Outlet Type/Pipe Size	"C" Body HT. DIM.	ADD
Inside Caulk (2010)	C02, C03, C04		4"	N/C
Speedi-Set SW (2005)	L02, L03, L04		4"	N/C
Speedi-Set XH (2005)	LXH02, LXH03, LXH04		4"	N/C
Threaded (2010)	T02, T03, T04		3"	47.00
No-Hub (2005)	Y02, Y03, Y04		4"	N/C

OPTIONS:

Option	Description	ADD
-ARI	Acid Resistant Inside	102.00
-B	Sediment Bucket	65.00
-BB	Bronze Body, 02-04" 05-06"	734.00 2,255.00
-BFV	Ball Float Bkwtr Valve	230.00
-DID*	Drain Installation Device	83.00
-G	Galvanized Body	119.00
-H	Hinged Grate (6, 7, 8")	168.00
-P	Trap Primer Conn	N/C
-U	Vandal Proof Screws	33.00
-V	Flapper Backwater Valve	230.00

A OUTLET SIZE	B TOP SIZE	X MIN MAX	XX MIN MAX	PB TOP	†NB TOP	CP TOP	APPROX. WEIGHT LBS.
02, 03, 04"	05 x 05"	1 1/4 2 1/4	3/4 1 5/8	359.00	392.00	417.00	12
02, 03, 04"	06 x 06"	1 1/4 2 1/4	3/4 1 5/8	413.00	436.00	470.00	13
02, 03, 04"	07 x 07"	1 1/4 2 1/4	7/8 1 7/8	490.00	524.00	564.00	14
02, 03, 04"	08 x 08"	1 1/2 2 1/2	1 1 7/8	574.00	634.00	681.00	15
02, 03, 04"	09 x 09"	1 1/2 2 3/8	1 1 7/8	734.00	803.00	868.00	18
02, 03, 04"	10 x 10"	1 1/2 2 3/8	1 1 7/8	940.00	1,009.00	1,098.00	21

*Applies to 2005 only.

REGULARLY FURNISHED: Duco Cast Iron Body with Flashing Collar and Adjustable Square Strainer Head.

When ordering, specify drain body and strainer type, size and finish. Ex. 2005Y04 w/A05NB.

†REGULARLY FURNISHED



FLOOR DRAINS