

# Commercial Boxed Ground Hydrants



**BOX TYPE NON-FREEZE POST HYDRANT WITH 3/4" (19) OR 1" (25) INLET AND HOSE CONNECTION AND HEAVY DUTY COVER**



**FIG. # 5950 AND 5951**

Heavy Duty Box Ground Hydrant

## FUNCTION:

Hydrant with heavy duty hinged cover, box, particularly suitable for traffic areas which require a flush with ground non-freeze hydrant. Ideal for parking decks, outside exhibition areas, etc. The closing valve is located below the frost line. When hydrant is shut off water is drained from the casing through the drain hole in the valve housing.

## PRODUCT FEATURES:

- 3/4" (19) or 1" (25) inlet and hose connection
- Loose fit "T" handle key
- Bronze hydrant and casing with cast iron box, heavy duty cover and lifting device
- Commercial and light commercial construction applications
- Ideal for parking decks, outside exhibition areas, etc.
- Replacement parts are available in kit HPRK-41.

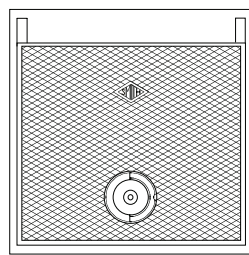

TOP VIEW

Fig. 5950 ... 3/4" (19) INLET  
Fig. 5951 ... 1" (25) INLET

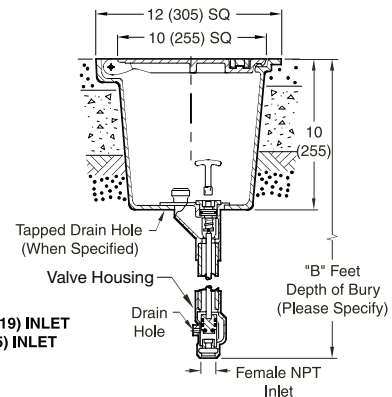

## Regularly Furnished:

Bronze Hydrant with Bronze Casing.  
"T" Handle Key and Cast Iron Hydrant Box with Heavy Duty Cover and Lifting Device.

## Variations:

- 1" (25) Hose Connection Adapter -HC1
- 1/8" (3) NPT Drain Hole in Box -N
- 1/8" (3) NPT Drain Hole in Valve Housing -NV
- "Water" Cast on Cover -W

## Optional Materials:

- Nickel Bronze Top -NB
- Polished Bronze Top -PB
- Rough Bronze Top -RB

**NOTE:** Dimensions shown in parentheses are in millimeters.

**NOTE:** All Jay R. Smith Mfg. Co. hydrants are manufactured with "NO-LEAD" brazing rings and USDA approved lubricants.

**NOTE:** Addition of a vacuum breaker will not allow draining of the casing. Smith is not responsible for any casings that burst or related incidents if the hydrant is supplied with a vacuum breaker.