

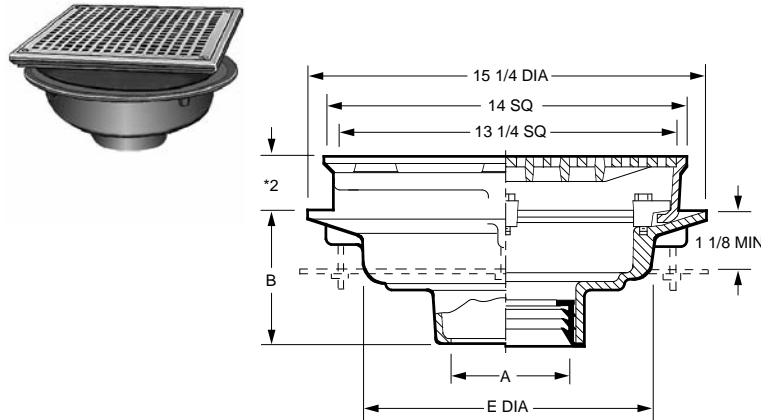

# ROOF DRAINS

## FIG. 1410 LARGE-14" DECK DRAINS

**FUNCTION:** Used in flat roofs and decks which are designed as parking decks or promenades for recreational purposes. Body and accessories are compatible for installation in all types of roof construction. Large square top blends in with "block" patterns and has sufficient open free area for proper drainage.



A OUTLET SIZE	TOP SIZE	E DIA	FREE AREA SQ IN	DUCO CI PB TOP	DUCO CI NB TOP	APPROX. WEIGHT LBS
02, 03, 04"	14"	11"	50.25	734.00	1,230.00	47
05, 06"	14"	11"	50.25	915.00	1,411.00	48
08"	14"	12 1/2"	50.25	1,102.00	1,598.00	65

**REGULARLY FURNISHED:** Duco Cast Iron Body and Flashing Clamp with Seepage Openings and Secured Square Hole Heavy Duty Grate.

**NOTE:** Floor drains or area drains used to drain areas subject to rainfall should have an open area equal to twice the cross sectional area of the connecting pipe.

### OUTLET VARIATIONS (Specify type of outlet and pipe size in inches.)

Outlet Type	Outlet Designation Outlet Type/Pipe Size	"B" Body HT. DIM.	ADD
Inside Caulk	C02, C03, C04, C05, C06	5"	N/C
	C08	6"	N/C
	L02, L03, L04	5"	N/C
Speedi-Set SW	LXH02, LXH03, LXH04	5"	N/C
Threaded	T02, T03, T04, T05, T06	3 3/4"	47.00
	T08	5"	47.00
No-Hub	Y02, Y03, Y04, Y05, Y06	5"	N/C
	Y08	6"	N/C

**OPTIONS:**

OPTION	DESCRIPTION	ADD
-B	Sediment Bucket	156.00
-C	Aluminum Underdeck Clamp	146.00
-C2	Sec Flashing Clamp	112.00
-CL	Angular Underdeck Clamp	296.00
-DE	Deck Elevator Extension	627.00
-DX	Wide Flange	801.00
-E	Extension, Up to 4"	402.00
	per inch over 4"	95.00
-G	Galvanized Cast Iron	540.00
-HP	Heelproof Grate	N/C
-M	Ductile Iron Grate	373.00
-NBM	DI Undergrate with NB Top, add to CI	986.00
-PBM	DI Undergrate with PB Top, add to CI	870.00
-R	Sump Receiver	164.00
-RDP	Roof Deck Plate	264.00
-U	Vandal Proof Grate	89.00
-W	3/8" Weep Holes in Collar (When "Loose-Set" pavers are required)	117.00

\*Add 1/8" when bronze top is specified.

ROOF DRAINS

## FIG. 1415 ADJUSTABLE ROOF DRAIN

**FUNCTION:** Used in roof systems where the insulated membrane assembly of waterproofing is provided. Used where built-up felt and asphalt waterproofing is installed on a flat roof construction which is designed for parking decks or promenades for recreational purposes. Adjustable extension sleeve permits top adjustment.

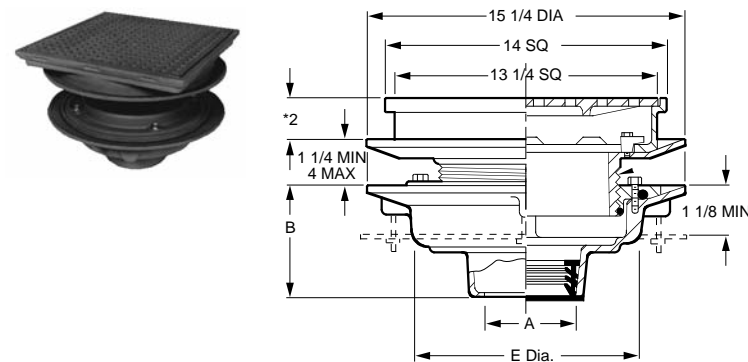

A OUTLET SIZE	TOP SIZE	E DIA.	FREE AREA SQ IN	DUCO CI PB TOP	DUCO CI NB TOP	APPROX. WEIGHT LBS
02, 03, 04"	14"	11"	50.25	1,164.00	1,660.00	65
05, 06"	14"	11"	50.25	1,347.00	1,843.00	72
08"	14"	12 1/2"	50.25	1,530.00	2,026.00	89

**REGULARLY FURNISHED:** Duco Cast Iron Body with Adjustable Extension Sleeve, Reversible Collar, Combined Flashing Collar and Clamp and Secured Square Hole Grate.

**NOTE:** Floor drains or area drains used to drain areas subject to rainfall should have an open area equal to twice the cross sectional area of the connecting pipe.

### OUTLET VARIATIONS (Specify type of outlet and pipe size in inches.)

Outlet Type	Outlet Designation Outlet Type/Pipe Size	"B" Body HT. DIM.	ADD
Inside Caulk	C02, C03, C04, C05, C06	5"	N/C
	C08	6"	N/C
	L02, L03, L04	5"	N/C
Speedi-Set SW	LXH02, LXH03, LXH04	5"	N/C
Threaded	T02, T03, T04, T05, T06	3 3/4"	47.00
	T08	5"	47.00
No-Hub	Y02, Y03, Y04, Y05, Y06	5"	N/C
	Y08	6"	N/C

**OPTIONS:**

OPTION	DESCRIPTION	ADD
-C	Aluminum Underdeck Clamp	146.00
-C2	Sec Flashing Clamp	112.00
-CL	Angular Underdeck Clamp	296.00
-G	Galvanized Cast Iron	540.00
-HP	Heelproof Grate	N/C
-M	Ductile Iron Grate	373.00
-NBM	DI Undergrate with NB Top, add to CI	986.00
-PBM	DI Undergrate with PB Top, add to CI	870.00
-R	Sump Receiver	164.00
-U	Vandal Proof Grate	89.00
-W	3/8" Weep Holes in Collar (When "Loose-Set" pavers are required)	117.00

\*Add 1/8" when bronze top is specified.

