



FLOOR DRAINS

FIG. 2484 WHITFORD STYLE HEAVY DUTY INDUSTRIAL DRAIN



FUNCTION: Used in packing houses and industrial plants where large quantities of water must be drained and heavy traffic is anticipated. Debris and solids are retained in a suspended bucket which is readily and easily emptied.

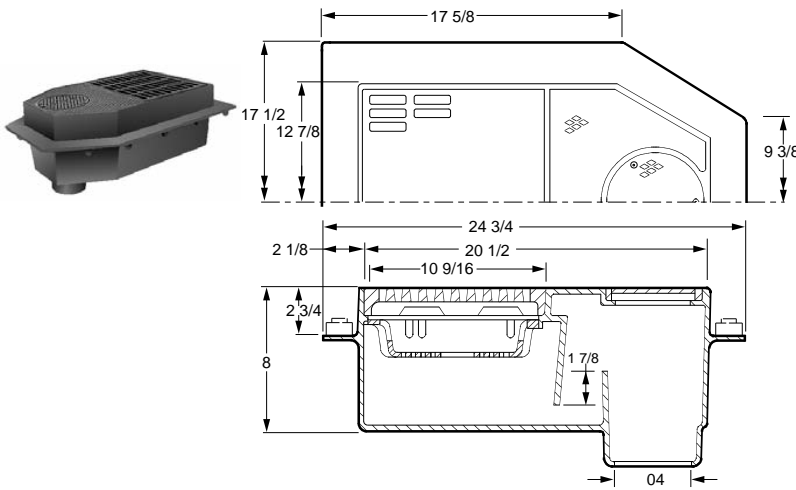

OUTLET SIZE	TOP SIZE	FREE AREA SQ IN	†DUCO CI	APPROX. WEIGHT LBS
04"	13 1/2 x 20 1/2"	38.5	2,158.00	110

REGULARLY FURNISHED:

Fabricated Steel Body with Acid Resistant Coating Inside and Outside with Heavy Duty Cast Iron Tractor Grate, Aluminum Sediment Bucket, and Secured Heavy Duty Cleanout Cover.

OUTLET VARIATIONS (Specify type of outlet and pipe size in inches.)

Outlet Type	Outlet Designation	Outlet Type/Pipe Size	ADD
Inside Caulk	C04N/C

OPTIONS:

-C	Flashing Clamp	239.00
-CIB	Cast Iron Bucket	N/C
-G	Galvanized CI	973.00
-M	Ductile Iron Grate	373.00
-U	Vandal Proof Screws	89.00
-W	With Seepage Holes	90.00

FLOOR DRAINS

FIG. 2488 HEAVY DUTY TRAFFIC PACKING HOUSE FLOOR DRAIN

FUNCTION: Used in packing houses and industrial plants where large quantities of water must be drained and heavy traffic is anticipated. Adjustable top conveniently adapts to different floor thicknesses. Top has four step adjustments in 1/2" increments. Large suspended sediment bucket is essential in packing house applications where considerable debris is anticipated.

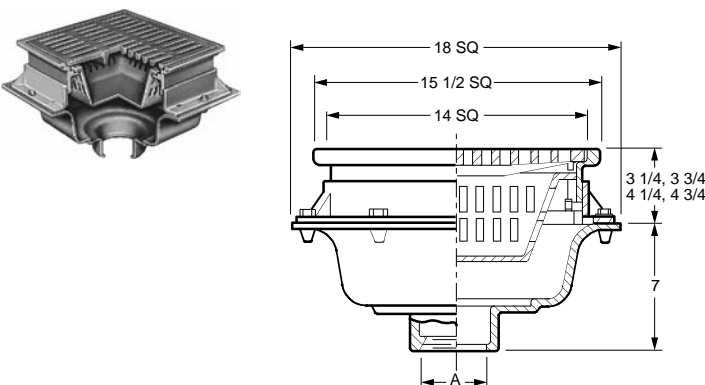

A	OUTLET SIZE	TOP SIZE	FREE AREA SQ IN	†DUCO CI	DUCO CI PB TOP	DUCO CI NB TOP	APPROX. WEIGHT LBS
03, 04"	15 1/2"	15 1/2"	63	1,908.00	2,686.00	2,726.00	105
05, 06"	15 1/2"	15 1/2"	63	1,908.00	2,686.00	2,726.00	109

REGULARLY FURNISHED: Duco Cast Iron Body, Flashing Collar and Adjustable Top with Ductile Iron Grate and Cast Iron Sediment Bucket.

OUTLET VARIATIONS (Specify type of outlet and pipe size in inches.)

Outlet Type	Outlet Designation	Outlet Type/Pipe Size	ADD
Inside Caulk	C03, C04, C05, C06N/C
Threaded	T03, T04, T05, T0647.00
No-Hub	Y03, Y04, Y05, Y06N/C

OPTIONS:

-AB	Aluminum Bucket	230.00
-ARI	ARC Inside	977.00
-ARIO	ARC In and Out	1,086.00
-E	Adj Ext, 5 to 6 1/2"	877.00
-FBSCI	Flat Bottom Strainer	58.00
-G	Galvanized CI	1,031.00
-U	Vandal Proof Screws	89.00

-LB	Less Bucket	111.00
-----	-------------	-------	--------

