



# FLOOR DRAINS

## SUFFIX V, W - ADJUSTABLE STRAINER WITH ANGLE GRATE



**FUNCTION:** Shower room drain set at wall and floor junction. Vertical grate openings prevent drain stoppage should flat surface become covered.

**OPTIONS:**  
 -U Vandal Proof Top ..... **ADD 33.00**

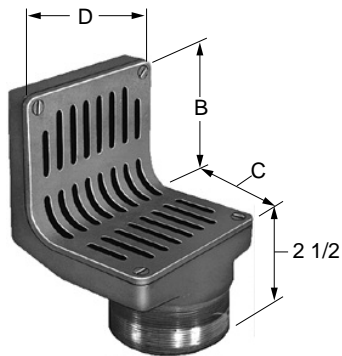

STRAINER SUFFIX	TOP SIZE			PB TOP	†NB TOP	CP TOP	APPROX. WEIGHT LBS
	B	C	D				
V	3 1/2"	3 1/2"	4 1/2"	983.00	1,073.00	1,184.00	10
W	6 3/4"	6 3/4"	6 1/2"	1,259.00	1,373.00	1,507.00	19

**REGULARLY FURNISHED:** Adjustable Angle Strainer with Secured Grate.

## SUFFIX X - ADJUSTABLE STRAINER EXTENSION ADAPTOR

**FUNCTION:** Used when strainer head must be raised to meet deeper floor fill.

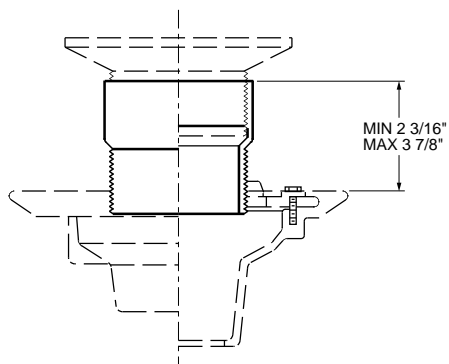

†DUCO CI (2010X)	GALV CI (2010XG)	CAST BRONZE (2010XCB)	APPROX. WEIGHT LBS
84.00	185.00	308.00	5

**REGULARLY FURNISHED:**  
 Duco Cast Iron Adjustable Extension Adaptor.

**NOTE:** Extensions can be stacked for increased maximum adjustment.

