



Commercial Post/Yard Hydrants

COMPRESSION-TYPE POST HYDRANTS WITH 1 1/2" (38) CONNECTIONS



FIG. # 5963

Compression-Type Post Hydrant with Wheel Handle

FUNCTION:

Fig. 5963 delivers year-round service outside or in unheated buildings. To provide freeze resistant functionality, the control valve is located below the frost line. Turning the handle raises or lowers the internal supply-line assembly, controlling the valve. Hydrant must be operated fully "on." Constructed of heavy brass, premium-quality gray iron and steel, the Fig. 5963 is designed for trouble-free reliability and easy maintenance.

PRODUCT FEATURES:

- 1 1/2" (38) bottom connection (available with N.P.T. tapping to connect to draw line).
- Constructed of heavy-duty red brass, quality gray iron and steel
- Freeze resistant
- Specify -BFH for Ball Check Valve and Vacuum Breaker
- Ideal for auxiliary fire protection, waste water treatment plants, railroads, and other areas requiring a large volume of water
- Wheel handle

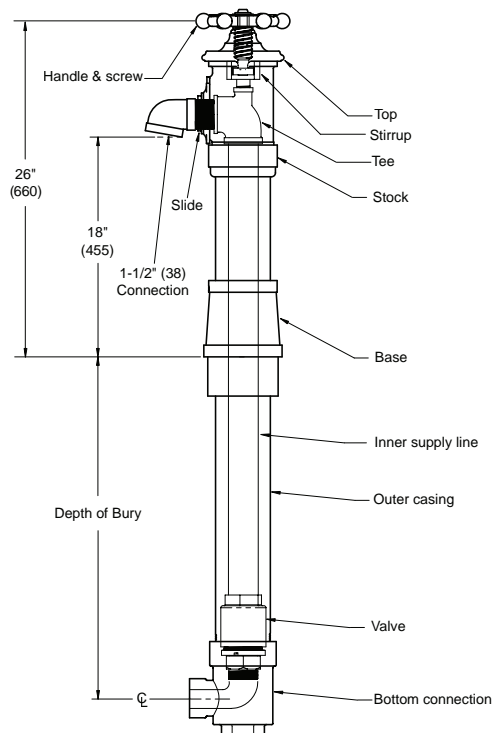

NOTE: Dimensions shown in parentheses are in millimeters.