



FLOOR DRAINS



FIG. 2005 (-F) FLOOR DRAIN AND ADJ. TILE FLANGE STRAINER WITH ROUND GRATE
FIG. 2010 (-F) FLOOR DRAIN AND ADJ. TILE FLANGE STRAINER WITH ROUND GRATE

FUNCTION: Provides integral flange set 5/32" below rim to receive floor covering. Flange may have option of tapped holes for securing pan and gasket.

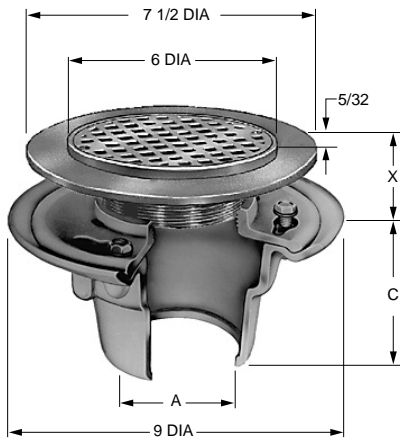

OUTLET VARIATIONS (Specify type of outlet and pipe size in inches.)

Outlet Type	Outlet Designation	Outlet Type/Pipe Size	"C" Body HT. DIM.	ADD
Inside Caulk (2010)	C02, C03, C04	4"	N/C
Speedi-Set SW (2005)	L02, L03, L04	4"	N/C
Speedi-Set XH (2005)	LXH02, LXH03, LXH04	4"	N/C
Threaded(2010)	T02, T03, T04	3"	47.00
No-Hub (2005)	Y02, Y03, Y04	4"	N/C

OPTIONS:

Option	Description	ADD
-ARI	Acid Resistant Inside	102.00
-B	Sediment Bucket	65.00
-BB	Bronze Body, 02-04"	734.00
	05-06"	2,255.00
-BFV	Ball Float Bkwtr Valve	230.00
-DID*	Drain Installation Device	83.00
-G	Galvanized Body	119.00
-P	Trap Primer Conn	N/C
-SH	Tapped Holes in Flange	74.00
-U	Vandal Proof Screws	33.00
-V	Flapper Backwater Valve	230.00

*Applies to 2005 only.

A OUTLET SIZE	STRAINER SIZE	X MIN MAX	DUCO CI PB TOP	DUCO CI †NB TOP	DUCO CI CP TOP	APPROX. WEIGHT LBS.
02, 03, 04"	06"	1 1/4 2 1/8	622.00	679.00	734.00	14

REGULARLY FURNISHED: Duco Cast Iron Body and Flashing Collar, Adjustable Strainer Head as Indicated by Suffix Letter Selected.

FIG. 2005 (-F37) FLOOR DRAIN AND ADJ. STRAINER WITH ROUND RECESSED GRATE
FIG. 2010 (-F38) FLOOR DRAIN AND ADJ. STRAINER WITH ROUND RECESSED GRATE

FUNCTION: Used in a non-traffic area when a funnel type strainer head is required and space does not allow use of the 3500 Series funnel. The extended rim allows use as an anti-flood and anti-splash drip pan.

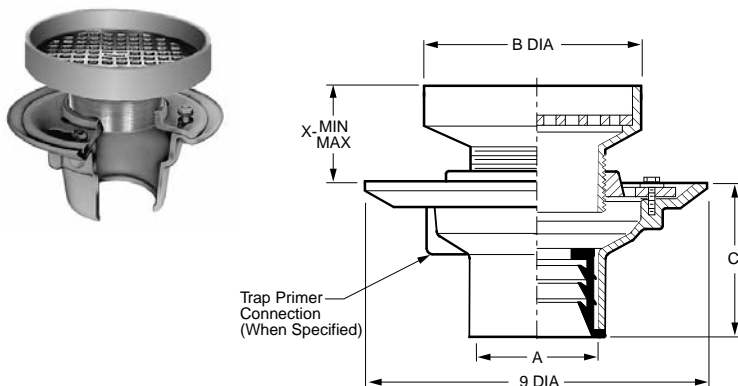

OUTLET VARIATIONS (Specify type of outlet and pipe size in inches.)

Outlet Type	Outlet Designation	Outlet Type/Pipe Size	"C" Body HT. DIM.	ADD
Inside Caulk (2010)	C02, C03, C04	4"	N/C
Speedi-Set SW (2005)	L02, L03, L04	4"	N/C
Speedi-Set XH (2005)	LXH02, LXH03, LXH04	4"	N/C
Threaded (2010)	T02, T03, T04	3"	47.00
No-Hub (2005)	Y02, Y03, Y04	4"	N/C

OPTIONS:

Option	Description	ADD
-ARI	Acid Resistant Inside	102.00
-BB	Bronze Body, 02-04"	734.00
	05-06"	2,255.00
-DID*	Drain Installation Device	83.00
-G	Galvanized CI Body	119.00
-GS	Galvanized Body & Strainer	
	F37 (add to CI)	209.00
	F38 (add to CI)	286.00
-P	Trap Primer Conn	N/C

*Applies to 2005 only.

A OUTLET SIZE	STRAINER SUFFIX	B TOP SIZE	X MIN MAX	CI TOP	PB TOP	†NB TOP	CP TOP	APPROX. WEIGHT LBS.
02, 03, 04"	F37	07"	2 5/8 3 1/2	326.00	622.00	679.00	735.00	19
02, 03, 04"	F38	09"	2 3/4 3 1/2	403.00	872.00	953.00	1,035.00	22

REGULARLY FURNISHED: Duco Cast Iron Body and Flashing Collar, Adjustable Nickel Bronze Strainer Head as Indicated by Suffix Letter Selected. Flush with Floor Funnel with Anti-Splash Rim and Grate.

When ordering, specify drain body and strainer type, size and finish. Ex. 2005Y04 w/A05NB.

