



# FLOOR DRAINS

**FIG. DX2568 SQUARE FLANGE FLOOR DRAIN WITH TRACTOR GRATE FOR WOOD DECK OR CONCRETE CONSTRUCTION**



**FUNCTION:** Used on promenade roof decks and roof recreational areas where waterproof traffic deck covering is to be installed. Wide flange allows adhesion of waterproof traffic deck covering, insuring watertight integrity, for particular use with wood deck construction.

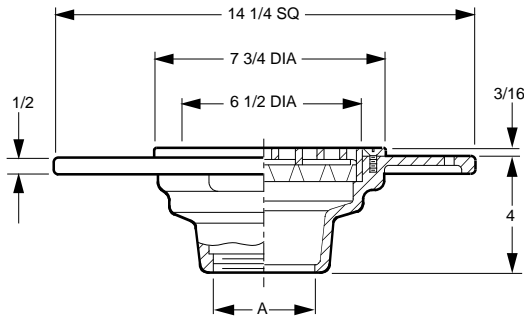

A OUTLET SIZE	TOP SIZE	FREE AREA SQ IN	DUCO CI PB TOP	DUCO CI †NB TOP	APPROX. WEIGHT LBS
02, 03, 04"	7 3/4"	12.5	709.00	847.00	31

**REGULARLY FURNISHED:** Duco Cast Iron Body with Nickel Bronze Tractor Grate and Rim.

**OUTLET VARIATIONS** (Specify type of outlet and pipe size in inches.)

Outlet Type	Outlet Designation Outlet Type/Pipe Size	ADD
Inside Caulk	C02, C03, C04	N/C
Threaded	T02, T03, T04	47.00
No-Hub	Y02, Y03, Y04	See Fig. 2646Y

**OPTIONS:**

Option	Description	ADD
-B	Sediment Bucket	75.00
-C	Underdeck Clamp	138.00
-G	Galvanized CI	414.00
-U	Vandal Proof Screws	89.00

FLOOR DRAINS

**FIG. 2570 HEAVY DUTY ROADWAY DRAIN**

**FUNCTION:** Used in roadways, parking and trucking areas to handle both heavy traffic loads and a large volume of surface water. Internal dome strainer protects the waste system from entrance of debris.

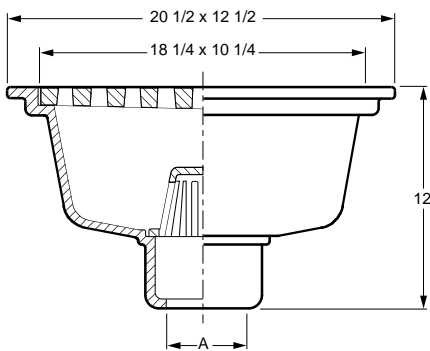

A OUTLET SIZE	TOP SIZE	FREE AREA SQ IN	DUCO CI	APPROX. WEIGHT LBS
03, 04"	20 1/2 x 12 1/2"	47	3,733.00	162
05, 06"	20 1/2 x 12 1/2"	47	3,733.00	162

**REGULARLY FURNISHED:** Duco Cast Iron Body with Loose Set Grate and Dome Bottom Strainer.

**OUTLET VARIATIONS** (Specify type of outlet and pipe size in inches.)

Outlet Type	Outlet Designation Outlet Type/Pipe Size	ADD
Inside Caulk	C03, C04, C05, C06	N/C

**OPTIONS:**

Option	Description	ADD
-B	Sediment Bucket	264.00
-G	Galvanized CI	2,006.00
-M	Ductile Iron Grate	1,202.00
-U	Vandal Proof Screws	145.00

