



FLOOR DRAINS

FIG. 2335 MEDIUM DUTY FLOOR DRAIN WITH 12" ROUND ADJUSTABLE TOP



FUNCTION: Used in medium traffic areas where large top drain is required. Adjustable top collar permits accurate positioning of top grate to meet finished floor level.

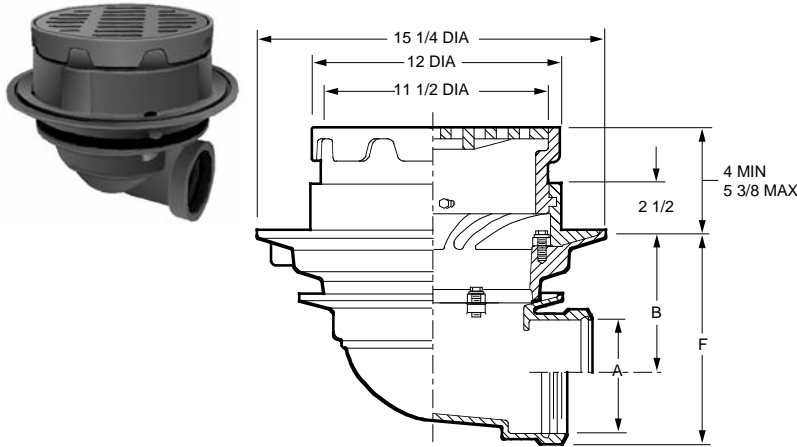

A OUTLET SIZE	TOP SIZE	FREE AREA SQ IN	B	†DUCO CI	DUCO CI PB TOP	DUCO CI NB TOP	APPROX. WEIGHT LBS
02"	12"	28.5	6 7/8"	1,159.00	1,554.00	1,616.00	76
03"	12"	28.5	6 3/8"	1,159.00	1,554.00	1,616.00	76
04"	12"	28.5	5 7/8"	1,159.00	1,554.00	1,616.00	76
05"	12"	28.5	5"	1,159.00	1,554.00	1,616.00	78
06"	12"	28.5	4 1/2"	1,159.00	1,554.00	1,616.00	78

REGULARLY FURNISHED: Duco Cast Iron Body and Flashing Collar with Adjustable Top and Bar Grate.

OUTLET VARIATIONS (Specify type of outlet and pipe size in inches.)

Outlet Type	Outlet Designation Outlet Type/Pipe Size	"F" Body HT. DIM.	ADD
Inside Caulk	C02	8 5/8"	N/C
	C03, C04	8 3/4"	N/C
	C05, C06	8 1/2"	N/C
Threaded	T02	8 5/8"	N/C
	T03, T04	8 3/4"	N/C
	T05, T06	8 1/2"	N/C
No-Hub	Y02	8 5/8"	N/C
	Y03, Y04	8 3/4"	N/C
	Y05, Y06	See Fig. 2646Y	

OPTIONS:	ADD
-B Sediment Bucket	156.00
-D Dome Grate, CI	84.00
-DNB Dome Grate, add to CI	753.00
-DPB Dome Grate, add to CI	647.00
-E Ext, ea 2" or fract	150.00
-G Galvanized CI	492.00
-H Hinged Grate	156.00
-M Ductile Iron Grate	157.00
-S Square Top, CI	208.00
-SNB Square Top, add to CI	753.00
-SPB Square Top, add to CI	654.00
-U Vandal Proof Grate	89.00

FIG. 2340 HEAVY DUTY FLOOR DRAIN WITH 12" ROUND ADJUSTABLE TOP AND TRACTOR GRATE

FUNCTION: Used in heavy duty traffic areas where large top drain is required. Adjustable top collar permits accurate positioning of grate to meet finished floor level.

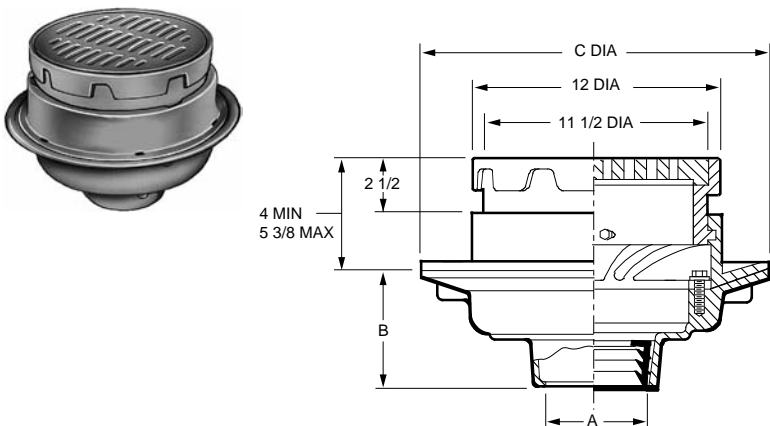

A OUTLET SIZE	TOP SIZE	FREE AREA SQ IN	C DIA	†DUCO CI	DUCO CI PB TOP	DUCO CI NB TOP	APPROX. WEIGHT LBS
02, 03, 04"	12"	29	15 1/4"	1,091.00	1,486.00	1,548.00	62
05, 06"	12"	29	15 1/4"	1,091.00	1,486.00	1,548.00	64

REGULARLY FURNISHED: Duco Cast Iron Body and Flashing Collar with Adjustable Top and Tractor Grate.

OUTLET VARIATIONS (Specify type of outlet and pipe size in inches.)

Outlet Type	Outlet Designation Outlet Type/Pipe Size	"B" Body HT. DIM.	ADD
Inside Caulk	C02, C03, C04, C05, C06	5"	N/C
	Speedi-Set SW	5"	N/C
	Speedi-Set XH	5"	N/C
Threaded	T02, T03, T04, T05, T06	3 3/4"	47.00
No-Hub	Y02, Y03, Y04, Y05, Y06	5"	N/C

OPTIONS:	ADD
-B Sediment Bucket	156.00
-DID Drain Installation Device	125.00
-FBSCI Flat Bottom Strainer, CI	36.00
-FP Frost Proof Bucket	223.00
-E Ext, ea 2" or fract	150.00
-G Galvanized CI	492.00
-M Ductile Iron Grate	157.00
-P Trap Primer Conn	99.00
-S Square Top, CI	208.00
-SNB Square Top, add to CI	753.00
-SPB Square Top, add to CI	654.00
-U Vandal Proof Grate	89.00

