

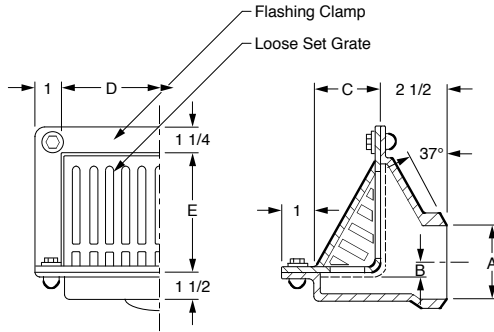

# SPECIALTIES, STAINLESS AND CARBON STEEL

## FIG. 9785 SCUPPER DRAIN

**FUNCTION:** Used at junction of roof and parapet. The angle grate prevents debris from blocking drainage.



### OUTLET VARIATIONS (Specify type of outlet and pipe size in inches.)

Outlet Type	Outlet Designation Outlet Type/Pipe Size	ADD
Butt Weld	BW02, BW03, BW04 BW05, BW06	POA
	Specify Schedule 5, 10, †40 or 80	

### OPTIONS:

Options	ADD
-A27G Carbon Steel Frame and Grate	POA
-U Vandal Proof Screws	POA
-304G Type 304 Frame and Grate (02-04")	POA
-304G Type 304 Frame and Grate (05-06")	POA
-316G Type 316 Frame and Grate (02-04")	POA
-316G Type 316 Frame and Grate (05-06")	POA

A OUTLET SIZE	B	C	D	E	FREE AREA SQ IN	†-CF8 (304) SS BODY, NB FRAME AND GRATE	-CF8M (316) SS BODY, NB FRAME AND GRATE	-A27 STL BODY NB FRAME AND GRATE	APPROX. WT. LBS
02, 03"	1/4"	3 1/4"	8 3/4"	5"	17.87	POA	POA	POA	17
04"	1/2"	3 1/4"	8 3/4"	5"	17.87	POA	POA	POA	17
05, 06"	1 3/4"	4"	10 1/2"	6 1/2"	35	POA	POA	POA	25

**REGULARLY FURNISHED:** CF8 (Equivalent to Type 304) Rough Finish Stainless Steel Body with Nickel Bronze Loose Set Grate and Clamping Collar.

SPECIALTIES

## FIG. 9790 PIT DRAIN WITH BACKWATER VALVE

**FUNCTION:** Used at base of side walls in pits, where low elevation requires a vertical inlet grate and side outlet roughing. Unless obstructed by debris or sludge, SMITH backflow valves prevent backflow which could damage equipment in pit. Used for gravity flow, not for high flow pump applications.

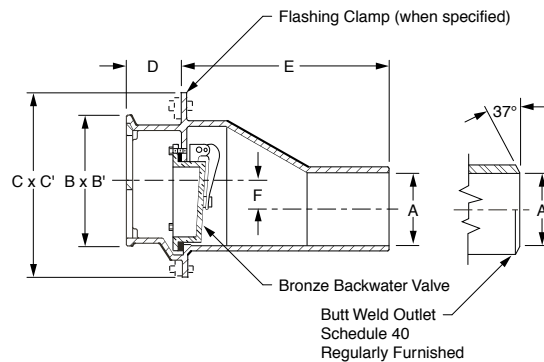
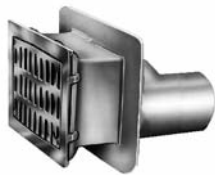

### OUTLET VARIATIONS (Specify type of outlet and pipe size in inches.)

Outlet Type	Outlet Designation Outlet Type/Pipe Size	ADD
Butt Weld	BW03, BW04, BW05 BW06, BW08	POA
	Specify Schedule 5, 10, †40 or 80	
Spigot	S03, S04, S05 S06, S08	POA

### OPTIONS:

Options	ADD
-A27G Carbon Steel Grate	POA
-C Galv. Clamping Collar	POA
-U Vandal Proof	POA
-V Type 304 SS Backwater Valve	POA
-316G Type 316 Grate	POA
	<b>DEDUCT</b>
-CIG Cast Iron Grate	POA

A OUTLET SIZE	B X B'	C X C'	D	E	F	FREE AREA SQ IN	†-CF8 (304) STAINLESS STEEL	-CF8M (316) STAINLESS STEEL	-A27 CARBON STEEL	APPROX. WT. LBS
03, 04"	6 3/4 x 9 1/2"	10 1/4 x 12"	3"	11 1/4"	2 3/4"	15.07	POA	POA	POA	47
05, 06"	7 3/4 x 11	9 3/4 x 13"	4"	13 1/4"	1 1/4"	24.57	POA	POA	POA	76
08"	12 1/2 x 14 1/2"	17 1/4 x 19"	4"	22"	3 1/2"	56.14	POA	POA	POA	164

**REGULARLY FURNISHED:** CF8 (Equivalent to Type 304) Rough Finish Stainless Steel Body with Secured Grate and Bronze Backwater Valve.

FOR INFORMATION ON POA ITEMS, PLEASE CONTACT YOUR LOCAL JAY R. SMITH REPRESENTATIVE

