

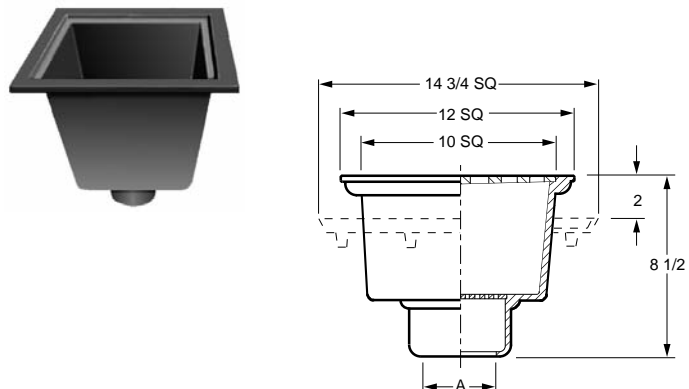

# FLOOR DRAINS

## FIG. 2633 LIGHT DUTY HOPPER DRAIN WITH FLAT BOTTOM STRAINER

**FUNCTION:** Hopper type drain for use in areas not subject to traffic.



**OUTLET VARIATIONS** (Specify type of outlet and pipe size in inches.)

Outlet Type	Outlet Designation	Outlet Type/Pipe Size	ADD
Inside Caulk	C02, C03, C04		N/C
No-Hub	Y02, Y03, Y04		See Fig. 2646Y
Threaded	T02, T03, T04		47.00

**OPTIONS:**

Option	Description	ADD
-DBS	Alum Dome Bottom Strainer	71.00
-F	Flange, Cast Iron	223.00
-FC	Flange w/Flashing Clamp	353.00
-G	Galvanized CI	414.00
-P	Trap Primer Connection	117.00

A OUTLET SIZE	TOP SIZE	FREE AREA SQ IN	†DUCO CI	DUCO CI PB TOP	DUCO CI NB TOP	APPROX. WEIGHT LBS
02, 03, 04"	12" SQ	28	487.00	906.00	952.00	30

**REGULARLY FURNISHED:** Duco Cast Iron Body with Flat Bottom Strainer.

## FIG. 2640 BLOOD AND WATER DRAINS

**FUNCTION:** Used in packing house slaughtering areas. Consists of two individual drains. Slotted grate drain permits drainage of animal blood to separate storage tank while adjacent drain connected to sewer is covered by solid ground joint plug. When area is to be washed down, the solid plug is put on the blood drain and the slotted grate on the sewer water drain, thus water used in the cleaning operation will be directed to sewer and will not enter the blood storage tank.

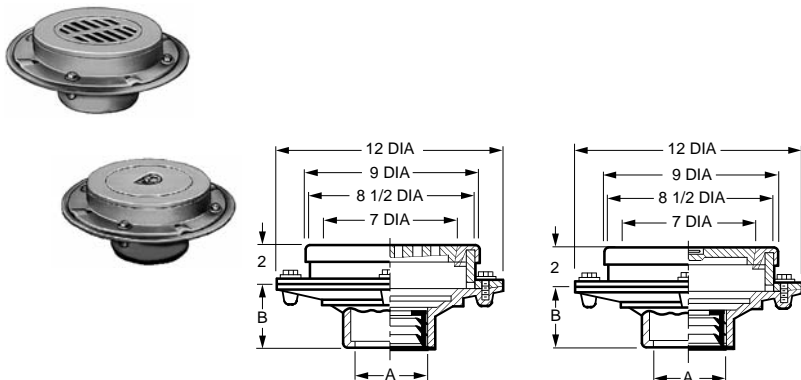

**OUTLET VARIATIONS** (Specify type of outlet and pipe size in inches.)

Outlet Type	Outlet Designation	Outlet Type/Pipe Size	"B" Body HT. DIM.	ADD
Inside Caulk	C02, C03, C04		3 3/4	N/C
Speedi-Set SW	L02, L03, L04		3 3/4	N/C
Speedi-Set XH	LXH02, LXH03, LXH04		3 3/4	N/C
Threaded	T02, T03, T04		2	95.00
No-Hub	Y02, Y03, Y04		3 3/4	N/C

**OPTIONS:**

Option	Description	ADD
-FBSCI	Flat Bottom Strainer, CI, ea	36.00
-G	Galvanized CI	514.00
-M	Ductile Iron Tops	330.00
-RB	RB Grate & Plug	1,360.00

A OUTLET SIZE	TOP SIZE	FREE AREA SQ IN	†DUCO CI GRATE & PLUG	DUCO CI w/BRZ GRATE & PLUG (RB)	DUCO CI w/NB GRATE & PLUG (RNB)	APPROX. WEIGHT LBS
02, 03, 04"	9"	10.3	915.00	2,275.00	2,598.00	50

**REGULARLY FURNISHED:** Two (2) Duco Cast Iron Bodies with Flashing Collar and Bronze Rim, Cast Iron Grate and Ground Joint Plug.

