



FLOOR DRAINS

FIG. 2005 (-G) FLOOR DRAIN AND ADJ. STRAINER WITH ROUND LOW DOME GRATE
FIG. 2010 (-G) FLOOR DRAIN AND ADJ. STRAINER WITH ROUND LOW DOME GRATE



FUNCTION: Used in gutters and recessed areas where excessive debris build-up is expected. Dome insures drainage even when partly covered.

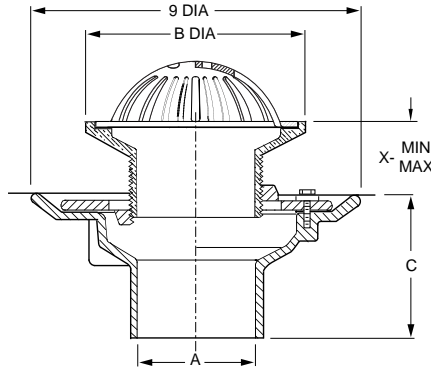

A OUTLET SIZE	B STRAINER SIZE	X MIN MAX	DUCO CI PB TOP	DUCO CI †NB TOP	DUCO CI CP TOP	APPROX. WEIGHT LBS.
02, 03, 04"	05"	1 1/4 2 1/4	392.00	413.00	444.00	11
02, 03, 04"	06"	1 1/4 2 1/4	447.00	495.00	532.00	13
02, 03, 04"	08"	1 1/2 2 1/2	586.00	621.00	671.00	16

REGULARLY FURNISHED: Duco Cast Iron Body with Flashing Collar and Adjustable Low Dome Strainer Head.

OUTLET VARIATIONS (Specify type of outlet and pipe size in inches.)

Outlet Type	Outlet Designation	Outlet Type/Pipe Size	"C" Body HT. DIM.	ADD
Inside Caulk (2010)C02, C03, C04	4"	N/C
Speedi-Set SW (2005)L02, L03, L04	4"	N/C
Speedi-Set XH (2005)LXH02, LXH03, LXH04	4"	N/C
Threaded(2010)T02, T03, T04	3"	47.00
No-Hub (2005)Y02, Y03, Y04	4"	N/C

OPTIONS:

Option	Description	ADD
-B	Sediment Bucket	65.00
-BB	Bronze Body, 02-04"	734.00
	05-06"	2,255.00
-BFV	Ball Float Backwater Valve	230.00
-DID*	Drain Installation Device	83.00
-G	Galvanized Body	119.00
-MS	SS Mesh on Dome	143.00
-P	Trap Primer Conn	N/C
-U	Vandal Proof Screws	33.00
-V	Flapper Type Backwater Valve	230.00

*Applies to 2005 only.

FLOOR DRAINS

FIG. 2005 (-H) FLOOR DRAIN AND ADJ. STRAINER WITH ROUND SOLID HINGED COVER
FIG. 2010 (-H) FLOOR DRAIN AND ADJ. STRAINER WITH ROUND SOLID HINGED COVER

FUNCTION: Used in areas where intermittent drain use is required. Solid cover prevents intrusion of chips, sawdust, etc., which are swept up before cover is opened for washdown. The secondary strainer prevents debris from entering the waste line.

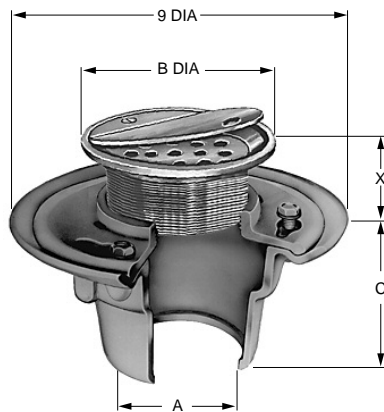

A OUTLET SIZE	B STRAINER SIZE	X MIN MAX	DUCO CI PB TOP	DUCO CI †NB TOP	DUCO CI CP TOP	APPROX. WEIGHT LBS.
02, 03, 04"	05"	1 1/4 2 1/4	495.00	528.00	569.00	13
02, 03, 04"	06"	1 1/4 2 1/4	519.00	586.00	634.00	14
02, 03, 04"	07"	1 1/4 2 1/4	759.00	847.00	921.00	16
02, 03, 04"	08"	1 1/2 2 1/2	792.00	857.00	935.00	16

REGULARLY FURNISHED: Duco Cast Iron Body and Flashing Collar, Adjustable Strainer Head as Indicated by Suffix Letter Selected.

OUTLET VARIATIONS (Specify type of outlet and pipe size in inches.)

Outlet Type	Outlet Designation	Outlet Type/Pipe Size	"C" Body HT. DIM.	ADD
Inside Caulk (2010)C02, C03, C04	4"	N/C
Speedi-Set SW (2005)L02, L03, L04	4"	N/C
Speedi-Set XH (2005)LXH02, LXH03, LXH04	4"	N/C
Threaded(2010)T02, T03, T04	3"	47.00
No-Hub (2005)Y02, Y03, Y04	4"	N/C

OPTIONS:

Option	Description	ADD
-ARI	Acid Resistant Inside	102.00
-BB	Bronze Body, 02-04"	734.00
	05-06"	2,255.00
-BFV	Ball Float Backwater Valve	230.00
-DID*	Drain Installation Device	83.00
-G	Galvanized Body	119.00
-P	Trap Primer Conn	N/C
-U	Vandal Proof Screws	33.00
-V	Flapper Type Backwater Valve	230.00

*Applies to 2005 only.

When ordering, specify drain body and strainer type, size and finish. Ex. 2005Y04 w/A05NB.

†REGULARLY FURNISHED

