

# EcoWash EWH-25

## 25-lb Capacity Soft Mount/350 G-Force Coin Washer/Extractor

### Features and Benefits:

- Coin or Card Ready
- Inverter Driven Motor
- Soft Mount
- Stainless Steel Cabinet
- Easy to Program and Easy to Use Controls
- Load Imbalance Detection Before Spinning
- Large, Convenient Supply Dispenser
- Flexible Water Level Settings
- Ergonomic, Easy-Grip Door Handle

### Why Purchase ADC EcoWash?



#### Soft Mount

EcoWash high spin washer/extractors feature a heavy-duty cast aluminum counter weight and our automatic imbalance detection system. Together these provide maximum stability and gentler movement, prolonging the unit's life.

#### Durable Door Safety Lock and Handle

The durable ergonomic design of the door handle combined with our Easy Lock™ door lock provides maximum convenience and safety.

#### Large, Convenient Supply Dispenser

Easy to use, this large supply dispenser allows you to conveniently load your detergent, bleach and fabric softeners before starting your wash cycle.

#### Disconnect

All Ecowash washers feature a standard quick disconnect for immediate power shutoff to your washer, eliminating the need for any additional cost of an external disconnect. This quick disconnect provides lockout/tagout capability to meet OSHA standards when performing preventative maintenance.



EWH-25 Coin Washer/Extractor

Your local ADC independent authorized distributor



# EcoWash EWH-25

## 350 G-Force High Spin Washer-Extractor

Features	EWH-25
<b>DRUM</b>	
Load Capacity (lb/kg)	25 / 11.3
Drum Volume (cu. ft./liter)	3.53 / 100
Drum Diameter (in/mm)	21 / 533
Drum Depth (in/mm)	16-3/4 / 425
<b>DIMENSIONS</b>	
Width (in/mm)	27-1/4 / 692
Depth (in/mm)	31-1/8 / 790
Height (in/mm)	45-3/4 / 1162
Weight (lb/Kg)	507 / 229.97
<b>DIMENSIONS WITH PACKAGING</b>	
Crated Width (in/mm)	29-1/8 / 739
Crated Depth (in/mm)	39-1/8 / 994
Crated Height (in/mm)	53-3/4 / 1365
Crated Weight (lb/Kg)	522 / 236.78
<b>DOOR</b>	
Height to Bottom of Door	16-3/4 / 425
Door Opening Diameter (in/mm)	11-1/2 / 292
<b>POWER</b>	
Voltage/Phase	208-240 / 1, 3ø
Full load current / Breaker (amps) - 1ø	5.26 / 15
Full load current / Breaker (amps) - 3ø	3.88 / 15
<b>CONNECTIONS</b>	
Water Inlet (in/mm)	3/4 / 19.05
Steam Inlet (in/mm)	1/2 / 12.7
Drain (in/mm)	3 / 76.2
<b>CYLINDER SPEED</b>	
Washing speed (r.p.m.)	50
Spinning speed (r.p.m.)	1000
G-Force	350

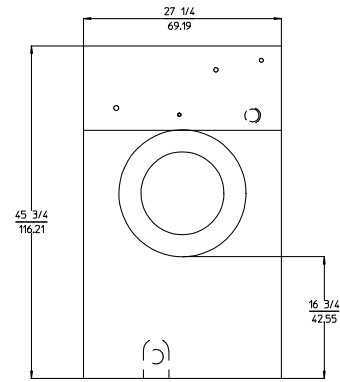

FRONT VIEW  
FRONT VIEW

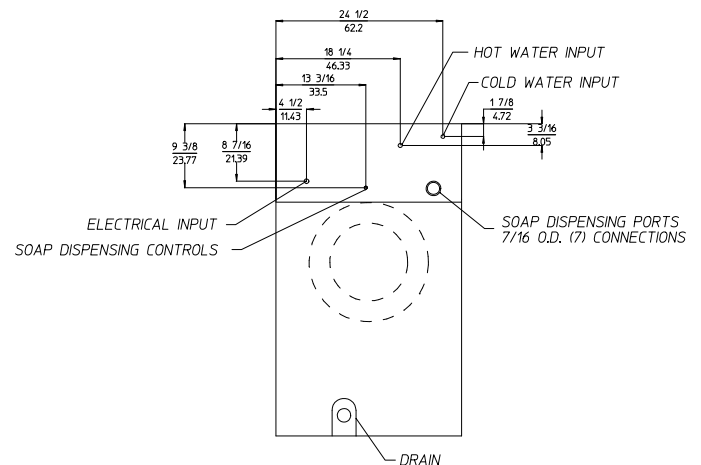

BACK VIEW



## Intuitive Micro Controls (IMC®) That Makes Washing Easy For You and Your Customers

Intuitive Micro Controls (IMC®) is our programmable microprocessor that is customizable, easy to program and easy to use. You can simplify existing programs; modify or delete the temperature and times of each phase of the cycle, as well as modify water levels to achieve maximum savings in your Laundromat. Multi vend pricing capability also enables you to maximize your Laundromat's revenue.



88 Currant Road Fall River, MA 02720-4781 • 508.678.9000 • Fax: 508.678.9447 • Email: sales@amdry.com

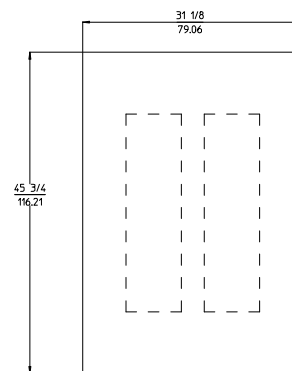

SIDE VIEW

P/N 450621 1/16/12  
REV 3/29/12

\* Specifications are subject to change without notice or obligation. Contact ADC for dimensions not shown or for clarification.

www.amdry.com