

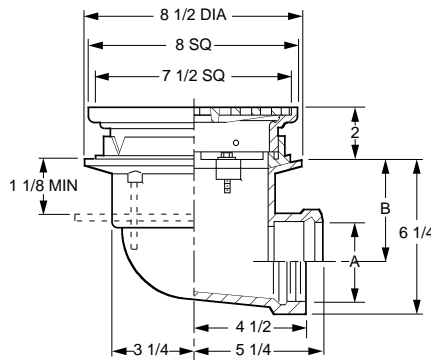

ROOF DRAINS

FIG. 1480 SMALL - 8" SQUARE PROMENADE DECK DRAIN

FUNCTION: Medium size deck drain for use in flat roof decks. Body and accessories are compatible for installation in all types of roof construction. Square medium size top fits in with "block" patterns. This drain should only be used in areas of moderate flow requirements.



OUTLET VARIATIONS (Specify type of outlet and pipe size in inches.)

Outlet Type	Outlet Designation Type/Pipe Size	Body HT. DIM.	ADD
Inside Caulk	C02, C03, C04	6 1/4"	N/C
Threaded	T02, T03, T04	6 1/4"	N/C
No-Hub	Y02, Y03, Y04		See Fig. 2646Y

OPTIONS:

Option	Description	ADD
-B	Sediment Bucket	128.00
-C	Underdeck Clamp	90.00
-C2	Sec. Flash. Clamp	112.00
-E	Extension, per inch to 4"	52.00
-E04P	4" Perf SS Extension	383.00
-G	Galvanized Cast Iron	164.00
-HP	Heelproof Grate	N/C
-M	Ductile Iron Grate	290.00
-R	Sump Receiver	156.00
-U	Vandal Proof Grate	89.00

ROOF DRAINS

A OUTLET SIZE	TOP SIZE	B	FREE AREA SQ IN	†DUCO CI	DUCO CI PB TOP	DUCO CI NB TOP	APPROX. WEIGHT LBS
02"	8"	4 1/2"	19	611.00	842.00	872.00	30
03"	8"	4"	19	611.00	842.00	872.00	30
04"	8"	3 1/2"	19	611.00	842.00	872.00	30

REGULARLY FURNISHED: Duco Cast Iron Body and Flashing Clamp with Seepage Openings and Secured Square Hole Light Duty Grate.

FIG. 1510 SCUPPER DRAIN - ANGLE GRATE

FUNCTION: Used at junction of roof and parapet. Side outlet 90° drains may be connected to outside downspout by using drain in conjunction with Fig. 1550 downspout adaptor. The angle grate prevents debris from blocking drainage.

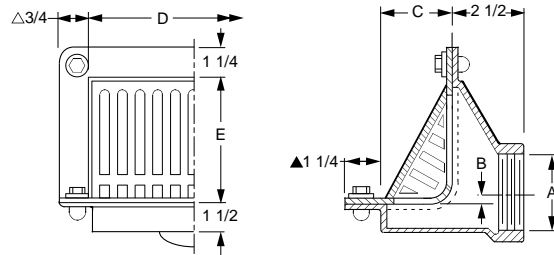

OUTLET VARIATIONS (Specify type of outlet and pipe size in inches.)

Outlet Type	Outlet Designation Type/Pipe Size	ADD
Threaded	T02, T03, T04	N/C
	T05, T06	N/C

OPTIONS:

Option	Description	ADD
-G	Galvanized Cast Iron	
	02, 03, 04"	145.00
	05, 06"	293.00
-SEC	Secured Grate	33.00
-U	Vandal Proof Grate	33.00

A OUTLET SIZE	B	C	D	E	FREE AREA SQ IN	†DUCO CI	DUCO CI RB FACE	DUCO CI PB FACE	DUCO CI NB FACE	APPROX. WEIGHT LBS
02"	*	3 1/4"	8 3/4"	5	17.75	377.00	638.00	835.00	992.00	16
03"	1/4"	3 1/4"	8 3/4"	5	17.75	377.00	638.00	835.00	992.00	16
04"	1"	3 1/4"	8 3/4"	5	17.75	377.00	638.00	835.00	992.00	16
05"	1 3/4"	4 1/4"	10 1/2"	6 1/2"	35	730.00	1,156.00	1,353.00	1,510.00	23
06"	1 3/4"	4 1/4"	10 1/2"	6 1/2"	35	730.00	1,156.00	1,353.00	1,510.00	23

* 02" Size "B" Dimension is 1/4" below flange, not above as shown.
 △For 05 & 06" size, add 1/2".
 ▲For 05 & 06" size, reduce by 3/16".

REGULARLY FURNISHED:

Duco Cast Iron Body, Flashing Clamp and Loose Set Grate.

