



# INTERCEPTORS

## FIG. 8560, 8560E SERIES LARGE CAPACITY STEEL OIL INTERCEPTORS



**FUNCTION:** Large capacity oil interceptors are used in large garages, service areas and industrial plants where waste laden with oil and sediment must be intercepted. The intercepted oils are drawn off by gravity to a storage tank or container. Any sediment which is included in the discharge is collected in a large sediment bucket and periodically removed. Interceptors should not be located directly in traffic areas. If required, specify extra heavy duty traffic cover.



**OPTIONS:**

- AC Aluminum Cover on Interceptor ..... **ADD POA**
- Y No-Hub Adaptor (4 req'd) ..... **See Fig. 2646Y**
- \*Inlet & Outlet, One Size Larger ..... **438.00**

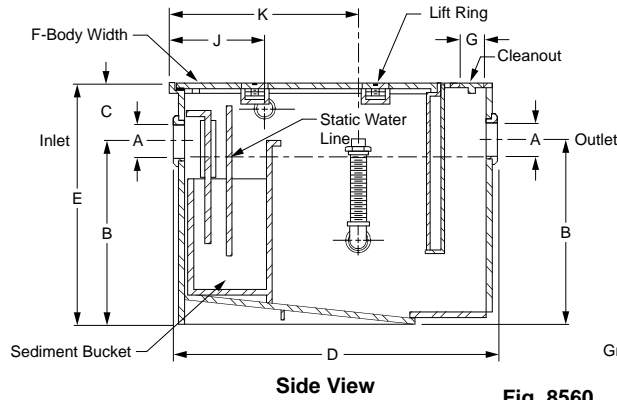

**Fig. 8560**

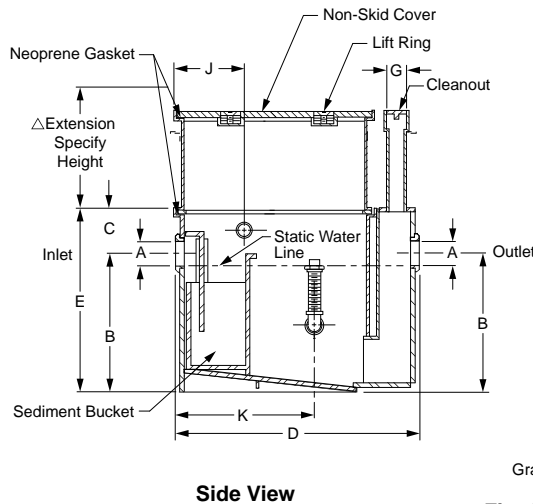
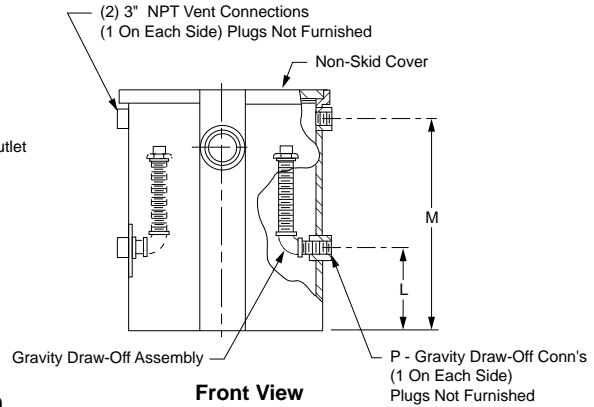

**Fig. 8560E**

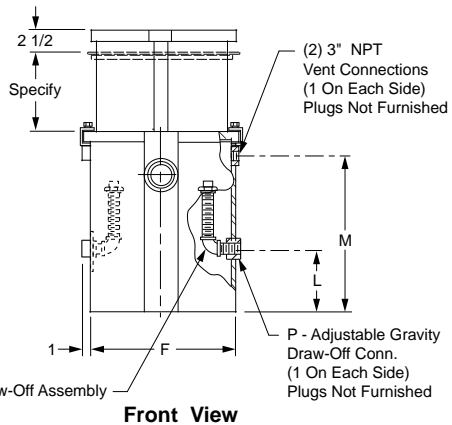

FIGURE NO.	GPM FLOW RATE	INLET & OUTLET SIZE *A	ROUGHING DIM			BODY		C.O. PLUG SIZE G	J	K	L	M	DRAW-OFF P	†STEEL DUCO COATED	ADD FOR:					APPROX. WT. LBS.
			B	C	D	E HEIGHT	F WIDTH								INTERC. Δ WITH UP TO 10" EXT. (-E)	EA 1" EXT. OVER 10"	H2O COVER	ANCHOR FLANGE (-F) (W/EXT ONLY)	FLANGE AND FLASH CLAMP (-FC) (W/EXT ONLY)	
8560	75	04"	21 1/2"	15 1/2"	50 3/4"	37"	30 1/2"	3"	21"	28 1/4"	13"	32 3/4"	2"	19,516.00	21,567.00	161.00	5,490.00	1,261.00	2,290.00	470
8565	100	04"	27"	16 1/2"	54 3/4"	43 1/2"	33 1/2"	3"	23"	30 1/4"	18 1/2"	39 1/4"	2"	21,877.00	24,182.00	172.00	7,555.00	1,410.00	2,562.00	690
8570	150	05"	33"	17 1/2"	60 3/4"	50 1/2"	38 1/2"	4"	25 1/2"	34 1/4"	23 1/2"	46 1/4"	2 1/2"	24,147.00	26,711.00	197.00	9,700.00	1,970.00	3,173.00	860
8575	200	05"	37"	17 1/2"	67 3/4"	54 1/2"	43 1/2"	4"	29"	38 1/4"	27 1/2"	50 1/4"	2 1/2"	33,993.00	38,609.00	207.00	11,064.00	2,112.00	3,706.00	1,310
8580	250	05"	40"	18"	73 3/4"	58"	47 1/2"	4"	32"	42 1/4"	30 1/2"	53 3/4"	2 1/2"	39,280.00	45,016.00	227.00	15,273.00	2,814.00	5,000.00	1,620
8585	350	05"	43 1/2"	18"	85 3/4"	61 1/2"	54 1/2"	4"	38"	50 1/4"	34"	57 1/4"	2 1/2"	51,265.00	59,227.00	286.00	23,119.00	3,560.00	5,978.00	2,030
8590	500	06"	48"	18"	103 1/4"	66"	64 1/2"	5"	46"	62 1/4"	38"	61 3/4"	2 1/2"	66,415.00	78,384.00	342.00	32,533.00	4,226.00	7,109.00	2,540

\*Available with larger inlet and outlet when specified.

Δ Specify Extension Height when ordering, measuring from top of interceptor to top of extension.

**REGULARLY FURNISHED:** Steel Interceptor with Gray Duco Coating Inside and Outside and Flow Control Fitting.

