



Roland

P-10 VISUAL SAMPLER

V-LINK USB 2.0 



Record to, and Playback from,
standard **SD** or **SDHC** Memory Cards.
Solid state reliability

Built-in
3.5 inch color LCD display
Eliminates the need for an external monitor

Press visual pads
to trigger video clips
Up to 864 clips can be assigned

Hi-Speed USB
for rapid data transfer
Direct transfer of media files from a computer

V-LINK ready
MIDI controllable from Roland V-LINK products

Enjoy easy-to-use, reliable playback of video and still images with the affordable video presenter from EDIROL.

Activate movies or stills with a simple touch. V-LINK support delivers automated control via MIDI.



P-10 VISUAL SAMPLER

V-LINK USB 2.0 SD Windows Vista®/Windows®XP Mac OS X

All-in-one, Easy-to-use

The P-10 is the latest compact visual tool from EDIROL. It is a standalone unit with all the necessary features to create a compelling visual presentation, such as real-time capture, special visual effects and an integrated LCD display. The P-10 employs SD or SDHC memory cards for fast, reliable storage and playback of media.

Easily Assign Clips to Pads

Capturing media from various sources (video decks, DVD players, digital cameras, etc) is extremely easy. Video is stored as Motion JPEG and still images as JPEGs. 72 banks with 12 pad sets offer the storage and quick recall of up to 864 clips.

Link your Audio & Video with V-LINK

Linking with V-LINK devices is easy. With one simple connection, real-time multi-media performance from a variety of instruments is yours.

Play Modes & Effects

Playback modes like Reverse, Strobe or Motion Control provide impressive effects for your audience. Slide Show enables animation from multiple still images.

Movie Play Modes

Mode	Description	Gate	Function
Forward Loop	Loops playback	Gate 1	Plays while a pad is pressed. Pauses the frame when the pad is released. Press again to start from the paused frame.
Alternative Loop	Repeats forward and reverse playback		
One Shot 1	Stops at final frame and pauses	Gate 2	Plays while a pad is pressed. Output is stopped when the pad is released.
One Shot 2	Stops at final frame without pausing		

Hi-Speed Data Transfer via USB

Import or export media files via USB. Free software for format conversion is included enabling easy conversion to P-10 compatible video files.

Illuminated Pads and Buttons

The sampler-like interface of the P-10 lets you perform visuals as if they were music. Self-lit pad buttons enhance playability on dark stages or at Front of House.

Affordable Visuals for your Application



Clubs (VJ)

Concerts & Houses of Worship

Sports & Events

Monitor Display

Brilliant 3.5inch color LCD provides playback monitoring and menu display.

MENU Button

Press to show the menu screen on the LCD display.

SPEED Dial

Adjusts playback speed of video clips from 0% to 400%.

AUDIO VOLUME Dial

Adjusts the audio output level.

PAD PARAM Button

Setup the playback parameter for each pad.

Movie Pad Parameter

Movie File	Select Movie to assign to a pad
Play Mode	Select playback mode
Start Frame	Select first frame of playback
End Frame	Select final frame of playback
Audio Sync	Turning this On enables audio effects such as reverse, speed adjust and repeat between AB markers.
Additional Audio File	Set audio file
Audio Level	Set audio output level
Strobe Time	Set strobe time between 0.5 - 2.0 sec.

Still Pad Parameter

Still Image File	Select still image to assign to a pad
Additional Audio File	Set audio file
Audio Level	Set audio output level
Effect SW	Select a visual effect from Slide Show, Strobe or Off
Slide Show Set	Select a type of slide show from 10 presets
Strobe Time	Set strobe time between 0.5 - 2.0 sec.



VALUE Dial and ENTER/EXIT Buttons

Enables quick selection of menu and setup

COLOR Dial

Adjust the saturation level of output color

VIDEO OUTPUT FADE Dial

Fades the output image to black or white. Blue or yellow can also be selected as color fades.

CAPTURE Buttons

Press STILL to capture still images or MOVIE for video. Captured images can be deleted with the DELETE button.

PAD COPY Button

Copies the data assigned to one pad and pastes it to another pad.

REPEAT AB Button

Enables loop playback of a portion of a video clip.

REVERSE/SLIDE SHOW Button

Starts reverse playback while a movie is played. Makes a Slide Show when a still image is being output.

STROBE Button

Applies a strobe effect to the movie clip.

EXT SOURCE Button

Shows the image being sourced via the INPUT jacks on the rear panel (like a DVD player, camera, etc).

BANK Buttons

Select a pad bank from A to F. One bank can have up to 12 variations.

Visual Pads

Press to play a movie or still. Red when a movie is assigned or blue when a still is assigned.

MIDI IN and OUT/THRU Jack (V-LINK ready)

Connect external MIDI device to remotely control P-10 or to receive control from P-10. Instant setup is possible if V-LINK compatible musical instrument is connected.



ANALOG INPUT Jacks (L/R Audio, Video and S-Video)

For connection with source devices like DVD players, cameras or video decks.

ANALOG OUTPUT Jacks (L/R Audio, Video and S-Video)

For connection with output devices like projectors, plasmas, etc. Video and Audio mixers are ideally connected to these.

INPUT LEVEL Dial

Adjusts audio input level. Input level can be displayed on built-in monitor.

MEMORY CARD Slot

Insert SD Card or large capacity SDHC card as recording media.

* 1GB SD card with demo clips is included.



USB Port

Data transfer of movie, still or audio from/to computer via USB 2.0

Capture and replay the media in your world.

You can easily capture video or still image materials from digital still cameras, video cameras or computers.

Enjoy real-time visual performance with your captured media. The P-10 provides easy and intuitive playback with its pads and bank selections.

V-LINK enables synchronized performance of audio and visuals. For example, synchronized playback with a sampler like the Roland SP-555 enables visual output in sync with the sampler's audio output. Cleverly synchronized sounds and visuals will deliver compelling and dramatic presentations.



Specifications			
Video Format	NTSC or PAL (selectable)	Visual Effects	Repeat, Reverse, Strobe, Speed, Color, Output Fade, Slide Show
Data Format	Movie : Motion JPEG (640 x 480 pixels) Stills : JPEG (640 x 480 pixels) Audio : WAV (16-bit/44.1 kHz)	Input and Output	Video Input : Composite (RCA pin type) x 1 S-Video Input : 4 pin mini DIN type x 1 Audio Input : RCA pin type (L/R) Video Output : Composite (RCA pin type) x 1 S-Video Output : 4 pin mini DIN type x 1 Audio Output : RCA pin type (L/R) Headphones : Stereo Phone type (1/4 inch)
Recording Time*	1GB : 15 minutes 2GB : 30 minutes 4GB : 60 minutes 8GB : 120 minutes 16GB : 240 minutes * These recording times are approximate. Your actual result may vary somewhat.	Other Terminals	MIDI In : 5 pin DIN type x 1 MIDI Out/ Thru : 5 pin DIN type x 1 USB Port : USB 1.1 or 2.0 High Speed (Mass Storage Class)
Storage Media	SD or SDHC memory card (compatible with 512 MB – 16 GB*) * As of March 2008.	Others	Display : 320 x 240 dots QVGA Color Display Power Supply : DC 9V (AC Adaptor) Current Draw : 900 mA Dimensions : 215 (W) x 300 (D) x 91 (H) mm (8.6 (W) x 12 (D) x 3.64 (H) inches) Weight : 1.9 kg (4.19 lbs)
Number of Clips	Movies only : 864 clips (12 pads x 72 banks) Stills only : 86,400 clips (100 images x 12 pads x 72 banks) * Total number of clips differs when both movies and stills are assigned to pads. * One project can contain up to 9,999 clips regardless to movie or still.	Accessories	Owner's Manual, AC adaptor, CD-ROM (P-10 Image Converter), SD Card (1 GB), SD Card Holder
Video Playback Mode	Forward Loop, Alternate Loop, One Shot (2 types), Gate (2 types)		

Block Diagram	Dimensions
---------------	------------

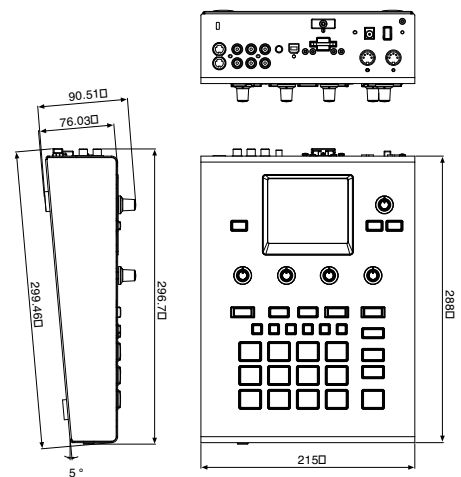
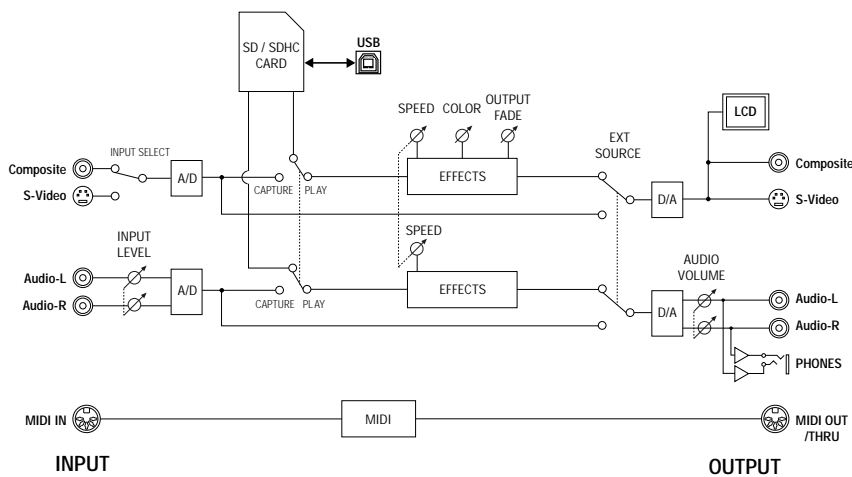

Unit: mm



Link your Audio & Video performances

V-LINK

■ Related Items

V-4 4-Channel Video Mixer
V-LINK

The world standard in compact video mixers. Four SD inputs and high-quality video effects at an affordable price.



V-8 8-Channel Video Mixer
V-LINK

Eight channel video mixer including built-in scan converter allowing direct connection from a computer. All the features of V-4 with more inputs and more effects.



●SDHC Logo is a trademark. ●Microsoft and Windows are registered trademarks of Microsoft Corporation. Windows® is known officially as : "Microsoft® Windows® operating system." Windows Vista is a registered trademark of Microsoft Corporation. ●Mac OS is a trademark of Apple Computer, Inc. ●All product names mentioned in this document are trademarks or registered trademarks of their respective owners.