

Raised Floor Enclosure Support System™

Simplifies The Installation of Enclosures onto a Raised Floor or Slab

Time-saving and practical, the Raised Floor Enclosure Support System consists of riser bases 2-1/2" high which provide the ability to perform field rough-in procedures prior to the arrival of the racks and enclosures. Also handy as a lower cable chase for passing cables between racks in multi-bay applications, riser bases feature 1/8" thick fully welded construction and an attractive black powder coat finish. Riser bases feature knockouts for passing cable between joined riser bases. Riser feet bring top of riser bases to a 12" height (or custom height) for use with raised floors. Raised floor support angles support floor tiles when used with riser bases and feet. Custom width, depth and height RIB Series riser bases are also available, please call for details.



Spec. #
96-923
for full
product
info.



RIB Series Riser Base
shown with MRK racks
and custom cable chase

accommodates DRK, MRK,
VMRK, VRK, WMRK, and WRK
Series racks and enclosures

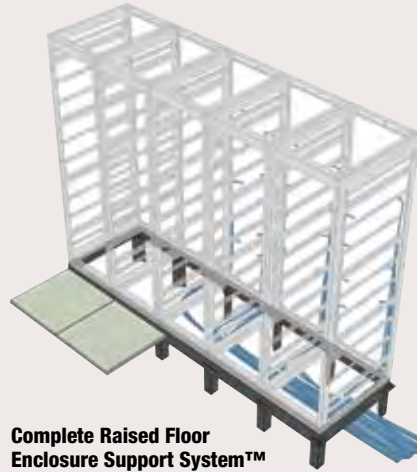

**Complete Raised Floor
Enclosure Support System™**
shown in typical raised
floor installation

example of riser
base in a raised
floor installation



photo courtesy of VT Group,
Charleston S.C., Gary Bridge, Project Manager

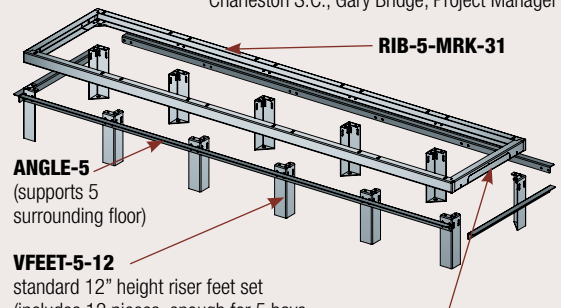

RIB-5-MRK-31
ANGLE-5
(supports 5
surrounding floor)
VFEET-5-12
standard 12" height riser feet set
(includes 12 pieces, enough for 5 bays)

custom height riser feet available,
please call for details

riser bases feature
cable pass-through laser
knockouts for use when
joining multiple bases

| RIB Series Riser Bases Part # | # of Bays | Raised Floor Riser Feet Part # | Raised Floor Support Angles Part # | Accommodates |
|-------------------------------|-----------|--------------------------------|------------------------------------|----------------------|
| RIB-1-WRK-27 | 1 | VFEET-1-12 | WANGLE-1 | WRK 27" deep racks |
| RIB-2-WRK-27 | 2 | VFEET-2-12 | WANGLE-2 | WRK 27" deep racks |
| RIB-3-WRK-27 | 3 | VFEET-3-12 | WANGLE-3 | WRK 27" deep racks |
| RIB-4-WRK-27 | 4 | VFEET-4-12 | WANGLE-4 | WRK 27" deep racks |
| RIB-5-WRK-27 | 5 | VFEET-5-12 | WANGLE-5 | WRK 27" deep racks |
| RIB-1-WRK-32 | 1 | VFEET-1-12 | WANGLE-1 | WRK 32" deep racks |
| RIB-2-WRK-32 | 2 | VFEET-2-12 | WANGLE-2 | WRK 32" deep racks |
| RIB-3-WRK-32 | 3 | VFEET-3-12 | WANGLE-3 | WRK 32" deep racks |
| RIB-4-WRK-32 | 4 | VFEET-4-12 | WANGLE-4 | WRK 32" deep racks |
| RIB-5-WRK-32 | 5 | VFEET-5-12 | WANGLE-5 | WRK 32" deep racks |
| RIB-1-WMRK-36 | 1 | VFEET-1-12 | WMANGLE-1-3642 | WMRK 36" depth racks |
| RIB-2-WMRK-36 | 2 | VFEET-2-12 | WMANGLE-2-3642 | WMRK 36" depth racks |
| RIB-3-WMRK-36 | 3 | VFEET-3-12 | WMANGLE-3-3642 | WMRK 36" depth racks |
| RIB-1-WMRK-42 | 1 | VFEET-1-12 | WMANGLE-1-3642 | WMRK 42" depth racks |
| RIB-2-WMRK-42 | 2 | VFEET-2-12 | WMANGLE-2-3642 | WMRK 42" depth racks |
| RIB-3-WMRK-42 | 3 | VFEET-3-12 | WMANGLE-3-3642 | WMRK 42" depth racks |
| RIB-1-WMRK-48 | 1 | VFEET-1-12 | WMANGLE-1-48 | WMRK 48" depth racks |
| RIB-2-WMRK-48 | 2 | VFEET-2-12 | WMANGLE-2-48 | WMRK 48" depth racks |
| RIB-3-WMRK-48 | 3 | VFEET-3-12 | WMANGLE-3-48 | WMRK 48" depth racks |
| RIB-1-MRK-26 | 1 | VFEET-1-12 | ANGLE-1 | MRK 26" depth racks |
| RIB-2-MRK-26 | 2 | VFEET-2-12 | ANGLE-2 | MRK 26" depth racks |
| RIB-3-MRK-26 | 3 | VFEET-3-12 | ANGLE-3 | MRK 26" depth racks |
| RIB-4-MRK-26 | 4 | VFEET-4-12 | ANGLE-4 | MRK 26" depth racks |

| RIB Series Riser Bases Part # | # of Bays | Raised Floor Riser Feet Part # | Raised Floor Support Angles Part # | Accommodates |
|-------------------------------|-----------|--------------------------------|------------------------------------|------------------------------|
| RIB-5-MRK-26 | 5 | VFEET-5-12 | ANGLE-5 | MRK 26" depth racks |
| RIB-1-MRK-31 | 1 | VFEET-1-12 | ANGLE-1 | MRK/VMRK/VRK 31" depth racks |
| RIB-2-MRK-31 | 2 | VFEET-2-12 | ANGLE-2 | MRK/VMRK/VRK 31" depth racks |
| RIB-3-MRK-31 | 3 | VFEET-3-12 | ANGLE-3 | MRK/VMRK/VRK 31" depth racks |
| RIB-4-MRK-31 | 4 | VFEET-4-12 | ANGLE-4 | MRK/VMRK/VRK 31" depth racks |
| RIB-5-MRK-31 | 5 | VFEET-5-12 | ANGLE-5 | MRK/VMRK/VRK 31" depth racks |
| RIB-1-MRK-36 | 1 | VFEET-1-12 | ANGLE-1-36 | MRK/VRK 36" depth racks |
| RIB-2-MRK-36 | 2 | VFEET-2-12 | ANGLE-2-36 | MRK/VRK 36" depth racks |
| RIB-3-MRK-36 | 3 | VFEET-3-12 | ANGLE-3-36 | MRK/VRK 36" depth racks |
| RIB-4-MRK-36 | 4 | VFEET-4-12 | ANGLE-4-36 | MRK/VRK 36" depth racks |
| RIB-5-MRK-36 | 5 | VFEET-5-12 | ANGLE-5-36 | MRK/VRK 36" depth racks |
| RIB-1-MRK-42 | 1 | VFEET-1-12 | ANGLE-1-42 | MRK/VRK 42" depth racks |
| RIB-2-MRK-42 | 2 | VFEET-2-12 | ANGLE-2-42 | MRK/VRK 42" depth racks |
| RIB-3-MRK-42 | 3 | VFEET-3-12 | ANGLE-3-42 | MRK/VRK 42" depth racks |
| RIB-1-DRK-31 | 1 | VFEET-1-12 | DANGLE-1-31 | DRK 31" depth racks |
| RIB-2-DRK-31 | 2 | VFEET-2-12 | DANGLE-2-31 | DRK 31" depth racks |
| RIB-3-DRK-31 | 3 | VFEET-3-12 | DANGLE-3-31 | DRK 31" depth racks |
| RIB-1-DRK-36 | 1 | VFEET-1-12 | DANGLE-1-3642 | DRK 36" depth racks |
| RIB-2-DRK-36 | 2 | VFEET-2-12 | DANGLE-2-3642 | DRK 36" depth racks |
| RIB-3-DRK-36 | 3 | VFEET-3-12 | DANGLE-3-3642 | DRK 36" depth racks |
| RIB-1-DRK-42 | 1 | VFEET-1-12 | DANGLE-1-3642 | DRK 42" depth racks |
| RIB-2-DRK-42 | 2 | VFEET-2-12 | DANGLE-2-3642 | DRK 42" depth racks |
| RIB-3-DRK-42 | 3 | VFEET-3-12 | DANGLE-3-3642 | DRK 42" depth racks |

BGR and EGR options are shown on rack series pgs.



SRB Series Seismic Certified Riser Base and Accessories

SRB Series Seismic Certified Riser Base

Designed to provide the same cable management facilities as our standard riser bases, but may be used in areas of high seismicity – Zone 4 or Seismic Design Category (SDC) “D”. The SRB Series seismic certified riser bases have been rigorously tested to satisfy the following codes and standards: 2007 & 2010 CBC; 2006, 2009 & 2012 IBC; ASCE 7-05 (2005 Edition) & ASCE 7-10 (2010 Edition) and the 2006 & 2009 editions of NFPA 5000 for use in areas of high seismicity – Zone 4 or Seismic Design Category (SDC) “D”. These are designed for Mission Critical and/or High-Importance Installations in locations with the highest level of seismicity and top floor or rooftop installations including those within UBC and CBC Essential facilities or IBC, ASCE 7, and NFPA 5000 Seismic Use Group III facilities. For all codes, the Importance factor I_p is 1.5.

With standard 24" height (custom heights available upon request), these riser bases are constructed of substantial 11-gauge steel. Accepts standard angles to support surrounding raised floor tiles. Available for select enclosures, these riser bases require the use of seismic brackets (see below for part #s). Seismic certified riser bases on MRK, VRK, DRK, WMRK and WRK Series



| Part # | Description | Accommodates | Seismic Brackets (1) set required per rack | Part # | Description | Accommodates | Seismic Brackets (1) set required per rack |
|----------------|------------------|-------------------------------|--|-----------------|------------------|----------------------|--|
| SRB-1-MRK-2624 | 1 bay riser base | MRK 26" depth racks | MRK-Z4 | SRB-2-WRK-3224 | 2 bay riser base | WRK 32" depth racks | WRK-Z4 |
| SRB-2-MRK-2624 | 2 bay riser base | MRK 26" depth racks | MRK-Z4 | SRB-3-WRK-3224 | 3 bay riser base | WRK 32" depth racks | WRK-Z4 |
| SRB-3-MRK-2624 | 3 bay riser base | MRK 26" depth racks | MRK-Z4 | SRB-1-WMRK-3124 | 1 bay riser base | WMRK 31" depth racks | WMRK-Z4 |
| SRB-1-MRK-3124 | 1 bay riser base | MRK 31" & VRK 31" depth racks | MRK-Z4, VRK-Z4 | SRB-2-WMRK-3124 | 2 bay riser base | WMRK 31" depth racks | WMRK-Z4 |
| SRB-2-MRK-3124 | 2 bay riser base | MRK 31" & VRK 31" depth racks | MRK-Z4, VRK-Z4 | SRB-1-WMRK-3624 | 1 bay riser base | WMRK 36" depth racks | WMRK-Z4 |
| SRB-3-MRK-3124 | 3 bay riser base | MRK 31" & VRK 31" depth racks | MRK-Z4, VRK-Z4 | SRB-2-WMRK-3624 | 2 bay riser base | WMRK 36" depth racks | WMRK-Z4 |
| SRB-1-MRK-3624 | 1 bay riser base | MRK 36" & VRK 36" depth racks | MRK-Z4, VRK-Z4 | SRB-1-WMRK-4224 | 1 bay riser base | WMRK 42" depth racks | WMRK-Z4 |
| SRB-2-MRK-3624 | 2 bay riser base | MRK 36" & VRK 36" depth racks | MRK-Z4, VRK-Z4 | SRB-2-WMRK-4224 | 2 bay riser base | WMRK 42" depth racks | WMRK-Z4 |
| SRB-3-MRK-3624 | 3 bay riser base | MRK 36" & VRK 36" depth racks | MRK-Z4, VRK-Z4 | SRB-1-WMRK-4824 | 1 bay riser base | WMRK 48" depth racks | WMRK-Z4 |
| SRB-1-MRK-4224 | 1 bay riser base | MRK 42" & VRK 42" depth racks | MRK-Z4, VRK-Z4 | SRB-2-WMRK-4824 | 2 bay riser base | WMRK 48" depth racks | WMRK-Z4 |
| SRB-2-MRK-4224 | 2 bay riser base | MRK 42" & VRK 42" depth racks | MRK-Z4, VRK-Z4 | SRB-1-DRK-3124 | 1 bay riser base | DRK 31" depth racks | MRK-Z4 |
| SRB-3-MRK-4224 | 3 bay riser base | MRK 42" & VRK 42" depth racks | MRK-Z4, VRK-Z4 | SRB-2-DRK-3124 | 2 bay riser base | DRK 31" depth racks | MRK-Z4 |
| SRB-1-MRK-4824 | 1 bay riser base | MRK 48" & VRK 48" depth racks | MRK-Z4, VRK-Z4 | SRB-1-DRK-3624 | 1 bay riser base | DRK 36" depth racks | MRK-Z4 |
| SRB-2-MRK-4824 | 2 bay riser base | MRK 48" & VRK 48" depth racks | MRK-Z4, VRK-Z4 | SRB-2-DRK-3624 | 2 bay riser base | DRK 36" depth racks | MRK-Z4 |
| SRB-3-MRK-4824 | 3 bay riser base | MRK 48" & VRK 48" depth racks | MRK-Z4, VRK-Z4 | SRB-1-DRK-4224 | 1 bay riser base | DRK 42" depth racks | MRK-Z4 |
| SRB-1-WRK-2724 | 1 bay riser base | WRK 27" depth racks | WRK-Z4 | SRB-2-DRK-4224 | 2 bay riser base | DRK 42" depth racks | MRK-Z4 |
| SRB-2-WRK-2724 | 2 bay riser base | WRK 27" depth racks | WRK-Z4 | SRB-1-DRK-4824 | 1 bay riser base | DRK 48" depth racks | MRK-Z4 |
| SRB-3-WRK-2724 | 3 bay riser base | WRK 27" depth racks | WRK-Z4 | SRB-2-DRK-4824 | 2 bay riser base | DRK 48" depth racks | MRK-Z4 |
| SRB-1-WRK-3224 | 1 bay riser base | WRK 32" depth racks | WRK-Z4 | | | | |

Custom heights & depths available on request 9"- 24"

Protective Grommet Strip

Place this flexible grommet material around openings and knockouts for additional cable protection. Fits any material up to 1/8" thick. Includes 30 ft. of black grommet.



| Part # | Description |
|--------|------------------|
| GR-30 | grommet, 30 feet |

Grommets

Grommets protect cables, and can be used on any 4" trade-size electrical knockout or used on 4-1/2" fan knockouts on Middle Atlantic Products top options. Allows for ganging without using expensive electrical fittings. GK-4G gland grommet blocks dust and helps control airflow.



Grommet Ring - GK4



Gland Grommet - GK-4G shown mounted on MW-4FT top option

| Part # | Description | Qty |
|---------|----------------------------|-----|
| GK-1X7G | 1" x 7" gland grommet ring | 4 |
| GK-3G | 3" gland grommet ring | 4 |
| GK-4G | 4" gland grommet | 4 |
| GK4 | 4" grommet ring | 4 |

