

KICKSTAND™

The KickStand™ is a microphone boom-arm isolator that combines a massive stabilizing base with an isolation pad to prevent resonance from the stage, riser or studio floor from entering the microphone. The KickStand helps eliminate this problem by decoupling the microphone stand from the stage, while providing a stable base to hold the microphone firmly in place.

The design begins with a thick, high-density acoustic foam isolation pad that covers the entire bottom plate. The special shape of the steel platform prevents the stand from resonating, and provides sufficient height to allow the boom arm and microphone to be articulated into an ideal position. The combination of soft foam to decouple and heavy steel to stabilize the microphone results in greater clarity and improved transient response.

Although originally developed for bass drums the KickStand is very effective on electric guitar, bass and other instruments that may be subject to floor resonance and other low frequency noise.

Features

- High density open cell acoustic foam base
- Laser cut steel platform for mass and stability
- Innovative design for the boom attachment
- Small footprint for drum riser

Benefits

- Stops floor, stage and drum riser resonance from entering the microphone
- Getting a great kick drum sound is quick and easy
- Makes it easier to set the kick drum sound
- Delivers a better sounding drum kit and overall mix

Cool Stuff

- Compact, fits any stage or drum riser
- Holds mic in place for better transient attack
- Makes it easier to get the job done
- Like a Recoil Stabilizer for drums!

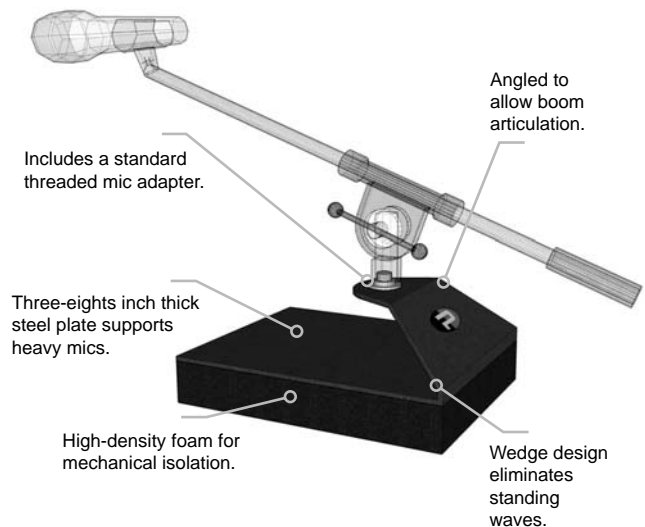

SPECIFICATIONS:

MATERIAL	3/8th" Steel and high-density acoustic foam
DIMENSIONS	7.5" (190mm) x 9.75" (248mm) x 4.5" (114mm)
ORDER NUMBER	P300-0200-00
COLOR	Steel: Black finish, paintable; Foam: charcoal

APPLICATIONS:

