

3", 4" and 5" Bottom Connected Industrial Thermometers

A sturdy straight form design commonly used for industrial applications and OEM equipment.

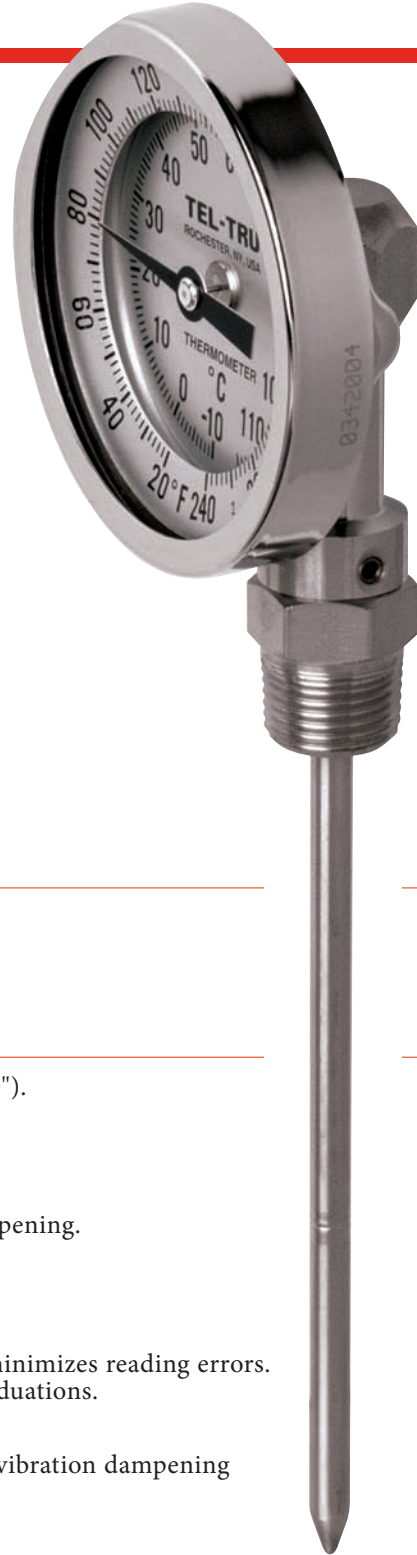

► MODEL CODES:

BC-350R	3" diameter head with calibration feature
BC-450R	4" diameter head with calibration feature
BC-550R	5" diameter head with calibration feature

► SPECIFICATIONS:

Stem Lengths:	2½", 4", 6", 9", 12", 15", 18" and 24" (available up to 120").
Stem Diameter:	.250" standard up to 42" stem. .375" standard over 42" stem.
Connection:	½" NPT.
External Reset:	Easy to calibrate by inserting Allen wrench into reset opening.
Construction:	304 stainless steel external parts. Welded construction. Corrosion resistant to most chemicals.
Hermetic seal:	Per ASME B40.3 dustproof and leakproof.
Dial:	True Anti-Parallax dial, easy-to-read from any angle, minimizes reading errors. Anodized aluminum with large black numbers and graduations.
Lens:	Glass.
Bimetal Coil:	Helix coil is silicone coated on ranges below 500°F for vibration dampening and to maximize heat transfer and response time.
Accuracy:	±1% full span per ASME B40.3 Grade A.
Over Temperature Limits:	Up to 250°F 100%; 250°F to 550°F, 50%; 550°F to 1000°F, continuous use up to 800°F, intermittent use over 800°F.





Tel-Tru® Manufacturing Company

408 St. Paul St., Rochester, New York 14605 USA

Phone: 585.232.1440 • 800.232.5335 • Fax: 585.232.3857 • E-mail: info@teltru.com • Web: www.teltru.com

➤ **STANDARD RANGES:**

Fahrenheit	°/Div.	Celsius	°/Div.	Dual	
				Fahrenheit	Celsius
-100/100	2°	-75/175	5°	-100/100	-75/40
-50/120	2°	-70/70	1°	-40/160	-40/70
-40/160	2°	-50/100	1°	0/140	-18/60
0/140	1°	-50/25	1°	0/180	-18/82
0/180	2°	-50/50	1°	0/220	-10/100
0/200	2°	-40/70	1°	0/250	-20/120
0/220	2°	-20/120	1°	20/240	-10/110
0/250	2°	-10/110	1°	25/125	-5/50
0/300	5°	0/50	1/2°	50/300	10/150
0/500	10°	0/60	1°	50/400	0/200
20/240	2°	0/80	1/2°	50/500	10/260
25/125	1°	0/100	1°	150/750	50/400
50/250	2°	0/150	1°	* 200/1000	*100/550
50/300	2°	0/200	2°		
50/400	5°	0/250	2°		
50/500	5°	0/300	5°		
50/550	5°	0/400	5°		
100/800	10°	0/450	5°		
150/750	10°	100/400	5°		
* 200/1000	10°	* 100/550	5°		

(Additional Ranges Available – Consult factory)

* Thermometers with temperature ranges 200/1000°F and 100/550°C are NOT RECOMMENDED FOR CONTINUOUS USE ABOVE 800°F/425°C (FOR INTERMITTENT USE ONLY).

➤ **OPTIONS:**

- Stem Position available in TOP (12:00), RIGHT (3:00), or LEFT (9:00) side connections (specify position of stem when ordering).
- Union connection or other connection types and sizes.
- Silicone filled.
- Other lenses are acrylic, polycarbonate, shatterproof glass or tempered glass.
- Other stem diameters .236" (6mm), .315" (8mm), .375" (9.5mm).
- 316SS wetted parts.
- Other configuration combinations available upon request.

Estimated Shipping Weights		
MODEL	DRY	SILICONE FILLED
BC-350R	. 14 oz.	1 lb. 1 oz.
BC-450R	. 1 lb. 3 oz. . . .	1 lb. 9 oz.
BC-550R	. 1 lb. 10 oz. . .	2 lb. 4 oz.

➤ **FOR HOW TO ORDER, SEE PAGE 6**

➤ **IMPORTANT NOTES:**

- 1) Thermowells are recommended for pressure, corrosive fluid or high velocity applications.
- 2) ASME B40.3— Bimetal thermometers manufactured by Tel-Tru and offered in this brochure are designed to meet or exceed this Standard issued by the American Society of Mechanical Engineers.

➤ **BC-350R, BC-450R AND BC-550R**

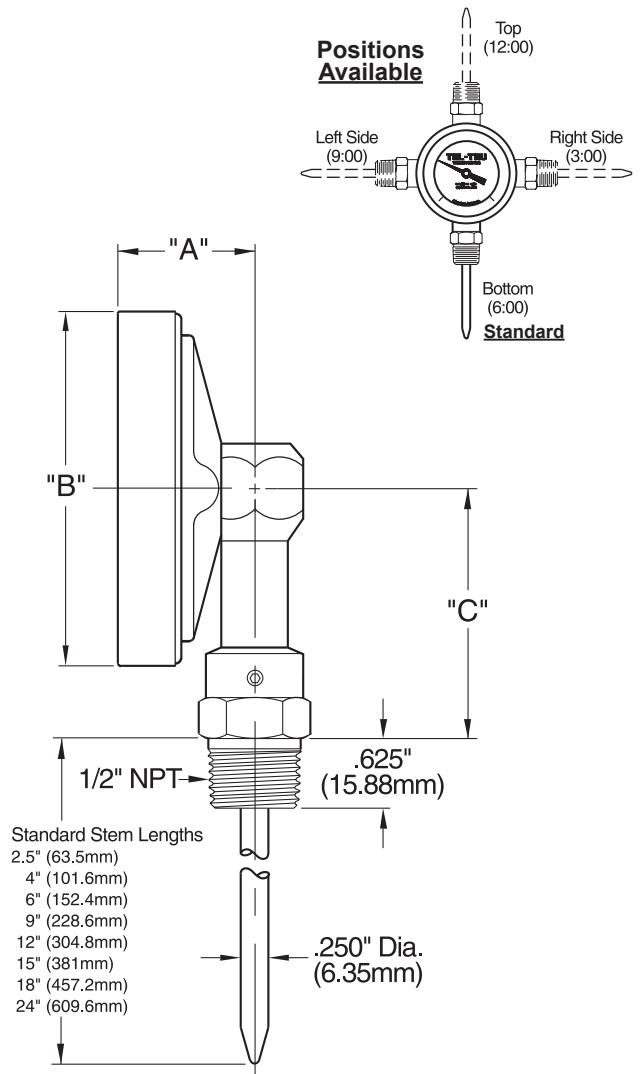

MODEL	"A"	"B"	"C"
BC-350R	1.187" (30.15mm)	3.187" (80.95mm)	2.300" (58.42mm)
BC-450R	1.187" (30.15mm)	4.115" (104.50mm)	3.000" (76.20mm)
BC-550R	1.625" (41.28mm)	5.040" (128.02mm)	3.000" (76.20mm)