

# MODEL 33

## INDUSTRIAL/HYDRAULIC PRESSURE GAUGES-DRY OR LIQUID FILLED

*Typically used in OEM applications.*



### SPECIFICATIONS:

Dial Size:	1-1/2", 2", 2-1/2" or 4"
Accuracy:	±3-2-3% ANSI Grade B ±2-1-2% ANSI Grade A (4" SS only)
Case:	304SS
Bezel:	304SS Crimped
Socket:	Brass or 316SS
Bourdon Tube:	Brass or 316SS
Movement:	Brass or 316SS
Lens:	Polycarbonate
Pointer:	Aluminum
Dial:	Heavy Gage Aluminum
Connection:	See <i>How To Order Chart</i>
Restrictor:	Brass only
Range:	See <i>Range Chart</i>
Scales:	See <i>Range Chart</i>

### ▶ AVAILABLE OPTIONS:

- Fill
- U-Clamp
- Front Flange (sold separately)
- Restrictor (SS)

**Note:** U-Clamp and Front Flange NOT available on 4"

Estimated Shipping Weights		
DIAL SIZE	DRY	FILLED
1-1/2"	4 oz.	5 oz.
2"	4 oz.	6 oz.
2-1/2"	5 oz.	9 oz.
4"	1 lb. 3 oz.	2 lbs.

### ▶ AVAILABLE CASE STYLES AND DIMENSIONS:

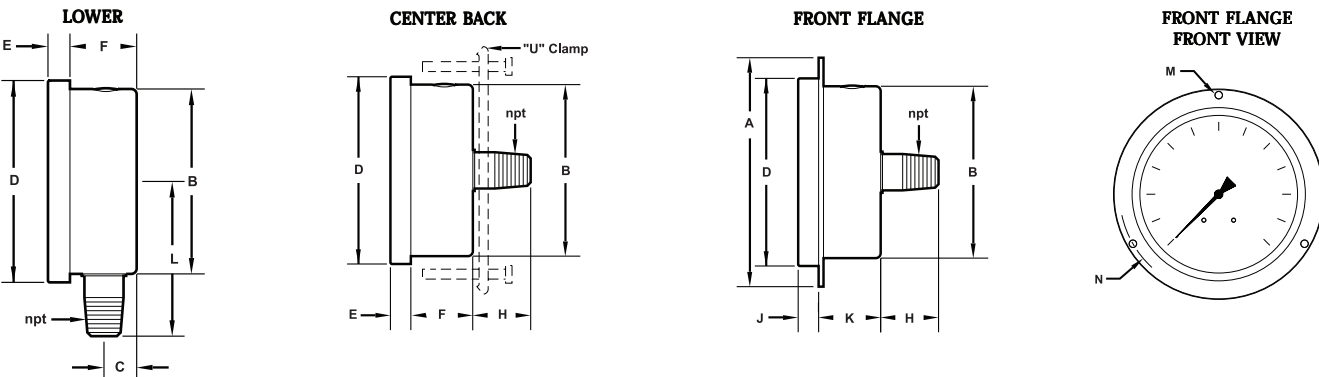

DIAL	A	B	C	D	E	F	H	J	K	L	M	N
1-1/2"	2.42" (62mm)	1.61" (41mm)	.34" (9mm)	1.77" (45mm)	.21" (5mm)	.79" (20mm)	.73" (19mm)	.21" (5mm)	.80" (20mm)	1.50" (38mm)	.14" (4mm)	1.97" (50mm)
2"	2.87" (73mm)	2.04" (52mm)	.40" (10mm)	2.21" (56mm)	.20" (5mm)	.90" (23mm)	.95" (24mm)	.19" (5mm)	.91" (23mm)	1.93" (49mm)	.14" (4mm)	2.44" (62mm)
2-1/2"	3.43" (87mm)	2.47" (63mm)	.41" (10mm)	2.68" (68mm)	.24" (6mm)	.94" (24mm)	.87" (22mm)	.18" (5mm)	1.00" (25mm)	2.20" (56mm)	.14" (4mm)	2.99" (76mm)
4"	5.12" (130mm)	3.88" (99mm)	.47" (12mm)	4.29" (109mm)	.30" (8mm)	1.12" (28mm)	1.38" (35mm)	.37" (9mm)	1.05" (27mm)	3.14" (80mm)	.17" (4mm)	4.57" (116mm)



Tel-Tru Manufacturing Company  
 408 St. Paul Street, Rochester, New York 14605 USA  
 Phone: 585.232.1440 • 800.232.5335 • Fax: 585.232.3857 • E-mail: info@teltru.com • Web: www.teltru.com

► HOW TO ORDER:

To Build A Part Number: Select one code from each column to build your gauge.

DIAL	MODEL CODE	TUBE & SOCKET	CASE	CONN. SIZE	CONN. LOCATION	CONN. TYPE	RANGE & SCALE	OPTIONS
1-1/2"	<b>15 33</b>	<b>B</b> = Brass <b>S</b> = SS	<b>S</b> = Stainless Steel	<b>1</b> = 1/8"	<b>L</b> = Lower <b>C</b> = Center Back	<b>1</b> = NPT	See Range Chart	Front Flange* <b>T</b> = Dry (No Fill) <b>G</b> = Glycerine Fill <b>S</b> = Silicone fill
2"	<b>20 33</b>	<b>B</b> = Brass <b>S</b> = SS	<b>S</b> = Stainless Steel	<b>4</b> = 1/4"	<b>L</b> = Lower <b>C</b> = Center Back	<b>1</b> = NPT	See Range Chart	Front Flange* <b>T</b> = Dry (No Fill) <b>G</b> = Glycerine Fill <b>S</b> = Silicone fill
2-1/2"	<b>25 33</b>	<b>B</b> = Brass <b>S</b> = SS	<b>S</b> = Stainless Steel	<b>4</b> = 1/4"	<b>L</b> = Lower <b>C</b> = Center Back	<b>1</b> = NPT	See Range Chart	Front Flange* U-Clamp** (sold separately) <b>T</b> = Dry (No Fill) <b>G</b> = Glycerine Fill <b>S</b> = Silicone fill
4"	<b>40 33</b>	<b>B</b> = Brass	<b>S</b> = Stainless Steel	<b>4</b> = 1/4"	<b>L</b> = Lower	<b>1</b> = NPT	See Range Chart	<b>T</b> = Dry (No Fill) <b>G</b> = Glycerine Fill <b>S</b> = Silicone fill
		<b>S</b> = SS	<b>S</b> = Stainless Steel	<b>2</b> = 1/2"				

\* Front Flange available on Back Mount only. When ordering specify part number 1-1/2" = 95-1726, 2" = 95-1727, or 2-1/2" = 95-1728

\*\* U-clamp on 2-1/2" dial is sold separately. Order part number 95-1701

Example:

**Specs:** 2-1/2", Model 33B, Brass, 1/4"Center Back, NPT, 0-60 psi/bar, Dry (no fill) and with Front Flange

**Select:**

25 33	B	S	4	C	1	D6F	T
-------	---	---	---	---	---	-----	---

**Ordering Format:** 2533BS4C1D6FT and 95-1728

► 33B STANDARD RANGES:

Note--Dual Scale: psi/bar/kpa

CODE = RANGE (psi)	INTERVALS (Hg) (psi)	DIVISIONS (Hg) (psi)
<b>V1Z</b> = 30" Hg	5"	.5"
<b>Z2Z</b> = 30-0-30	10" 5	1" .5
<b>Z3Z</b> = 30-0-60	10" 10	2" 1
<b>Z4Z</b> = 30-0-100	30" 10	2" 2
<b>Z5Z</b> = 30-0-160	30" 20	10" 5

CODE = RANGE (psi)	INTERVALS (psi)	DIVISIONS (psi)
<b>B7F</b> = 0-15	2	.2
<b>C6F</b> = 0-30	3	.5
<b>D6F</b> = 0-60	5	1
<b>D9F</b> = 0-100	10	1
<b>E4F</b> = 0-160	20	2
<b>E5F</b> = 0-200	20	2
<b>E8F</b> = 0-300	30	5
<b>F2F</b> = 0-400	50	5
<b>F4F</b> = 0-600	50	10

CODE = RANGE (psi)	INTERVALS (psi)	DIVISIONS (psi)
<b>F8F</b> = 0-1000	100	10
<b>H2F</b> = 0-1500	200	20
<b>H5F</b> = 0-2000	200	20
<b>H9F</b> = 0-3000	300	100
<b>J8F</b> = 0-5000	500	100

► 33S STANDARD RANGES:

Note--Single Scale: psi

CODE = RANGE (psi)	INTERVALS (Hg) (psi)	DIVISIONS (Hg) (psi)
<b>V1A</b> = 30" Hg	5"	.5"
<b>Z2A</b> = 30-0-30	10" 5	1" .5
<b>Z3A</b> = 30-0-60	10" 10	2" 1
<b>Z4A</b> = 30-0-100	30" 10	2" 2
<b>Z5A</b> = 30-0-160	30" 20	10" 5
<b>Z6A</b> = 30-0-200	30" 20	10" 5
<b>Z7A</b> = 30-0-300	30" 30	10" 5

CODE = RANGE (psi)	INTERVALS (psi)	DIVISIONS (psi)
<b>B7A</b> = 0-15	2	.2
<b>C6A</b> = 0-30	5	.5
<b>D6A</b> = 0-60	10	1
<b>D9A</b> = 0-100	10	2
<b>E4A</b> = 0-160	20	2
<b>E5A</b> = 0-200	20	2
<b>E8A</b> = 0-300	50	5
<b>F2A</b> = 0-400	50	5
<b>F4A</b> = 0-600	100	10

CODE = RANGE (psi)	INTERVALS (psi)	DIVISIONS (psi)
<b>F8A</b> = 0-1000	100	20
<b>H2A</b> = 0-1500	300	20
<b>H5A</b> = 0-2000	200	20
<b>H9A</b> = 0-3000	500	50
<b>J8A</b> = 0-5000	1000	100
<b>K1A</b> = 0-6000	1000	100
<b>K2A</b> = 0-7500	1500	100
<b>K4A</b> = 0-10,000	1000	200

IMPORTANT NOTES:

- Intervals and division based on 4" dial size--SPECS MAY VARY.
- Other ranges available, minimum quantities required.