

Jay R. Smith Mfg. Co.®

FloodGate®

Automatic
Backwater
Valve



FLOOD-GATE® VALVE, DIMENSIONS AND OPTIONS



FLOOD-GATE VALVE

7140Y04 4 in. (100 mm), 60 lbs.

7140Y06 6 in. (150 mm), 90 lbs.

U.S. Patent No. 5,538,032
Other U.S. and foreign patents pending

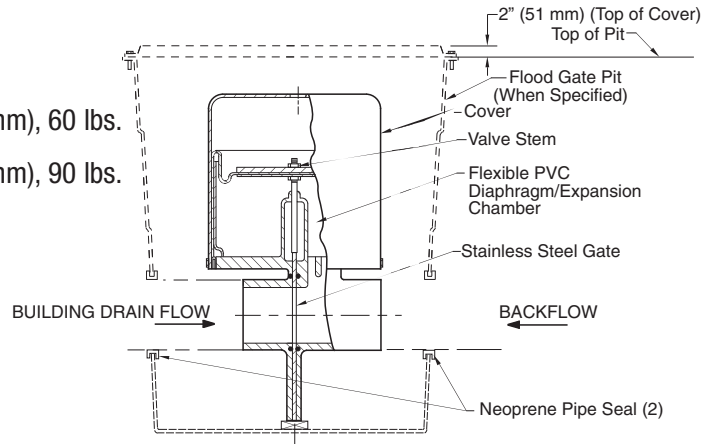

See back cover for dimensions

OPTIONS

FLOOD-GATE PIT

-FGP (Poly Pit, secured, Gasketed Poly Lid, Hardware), 25 lbs.

-FGS (Poly Pit, secured, Gasketed Steel Lid, Hardware), 69 lbs.

-FGSL Steel Lid Only, 42 lbs.

NOTE: All Flood-Gate Pits (are furnished with two pipe gasket seals) - designate 4" or 6" valve.

Pit can only be located in non-traffic areas.

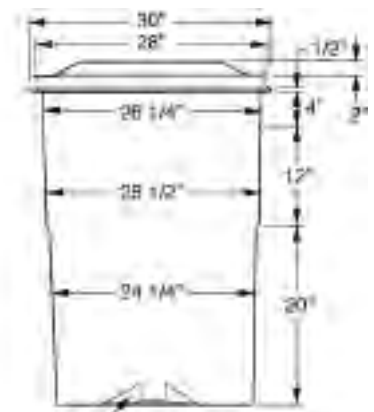

Integral Valve Support Block to position Valve in pit.



FLOOD-GATE ALARM

-FGA

- Alarm Control Box
- 35 ft. of Cable
- Sensor
- One (1) 9 volt battery* and/or 120 volt A/C power plug

*9 volt battery not included

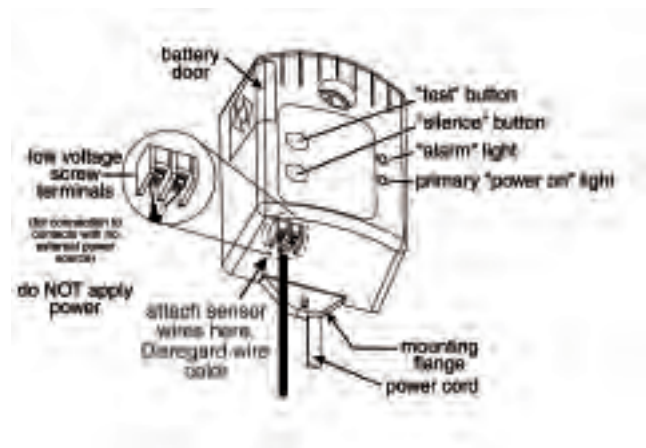

FLOOD-GATE® SYSTEM SPECIAL INSTALLATIONS

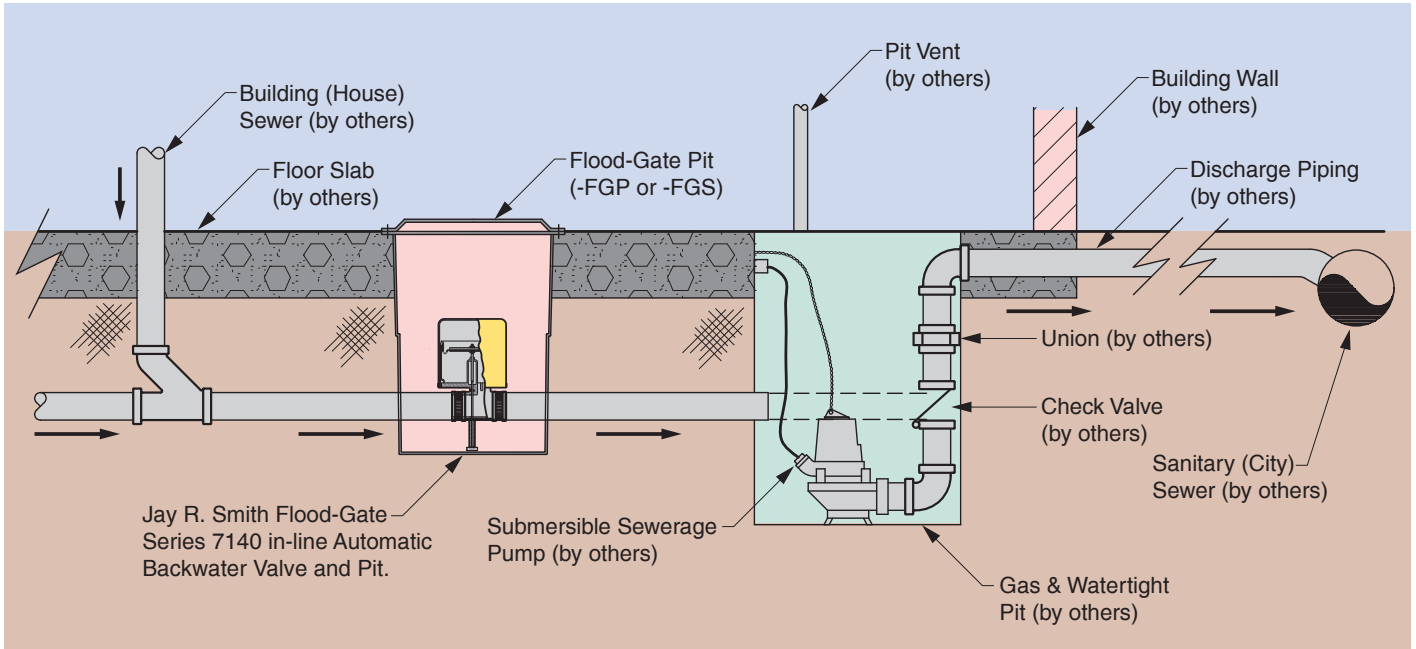

Detail - in-line backwater valve and sewage pump

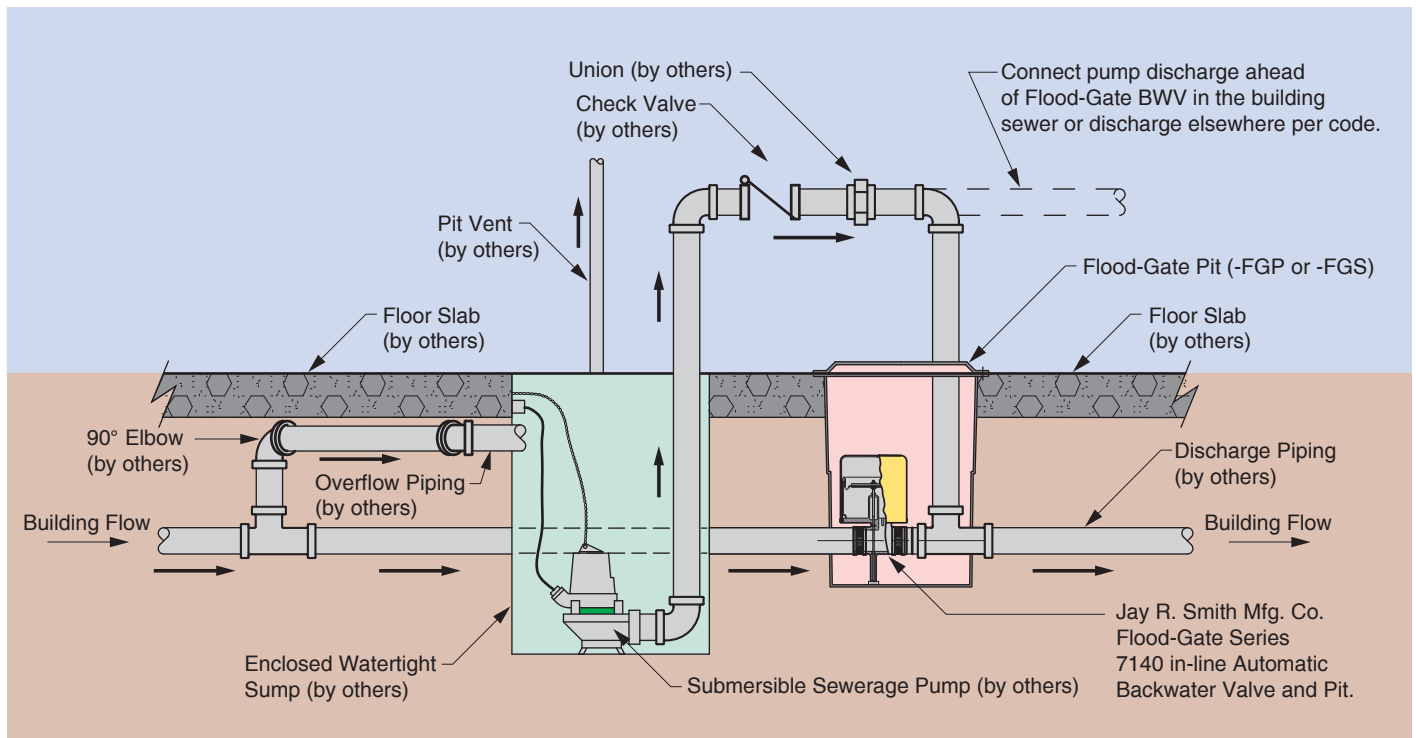

Detail - in-line backwater valve with emergency sewage pump

FLOOD-GATE® SPECIFICATIONS

Application

Backwater Valve for gravity sanitary drainage system connected to municipal sanitary sewers or septic tanks.

Material Specifications

The assembly comprises numerous parts. The following is a brief description of the main components.

1. **Gate** - Manufactured from stainless steel type 304 with full port opening and integral closing stopper.
2. **Body** - Two cast iron halves, designed to bolt together to enclose gate. Cast iron shall be Class 25 to ASTM A48. Both sections are equipped with barrels suitable for mechanical coupling to upstream and downstream sections of pipe. Out (or downstream) fitting equipped with full port opening. Each half incorporates a continuous groove around the circumference of the opening to accept an O-ring. These O-rings act to seal against the gate.
3. **Spacer** - Stainless steel gasket placed between the two body halves to permit the (thinner) gate to slide within the two halves of the body.
4. **Expansion chamber** - Flexible PVC diaphragm.

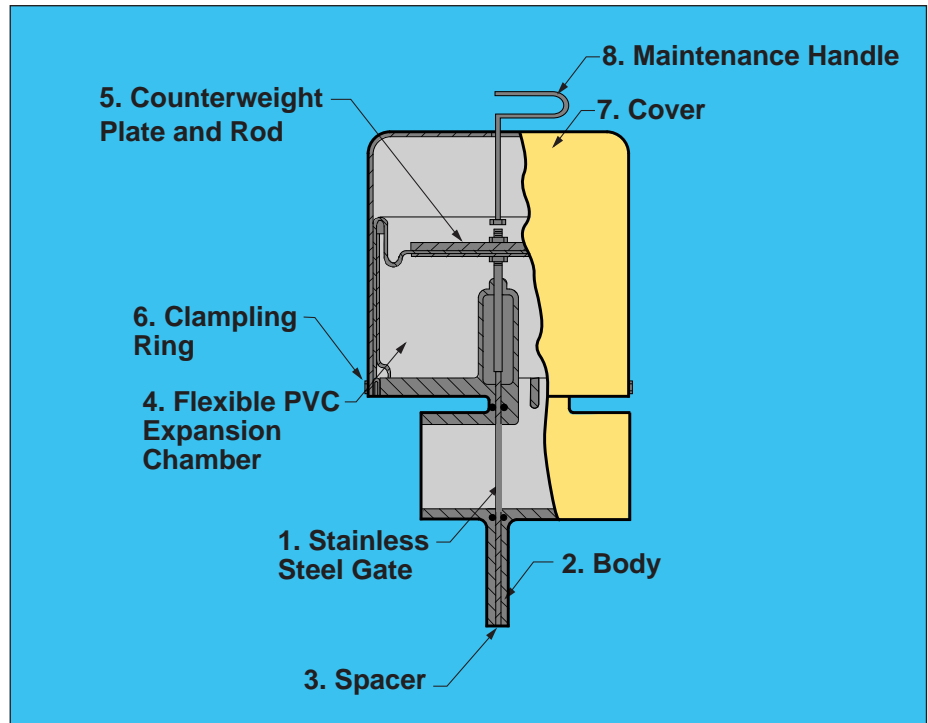

5. **Counterweight Plate, Plate Weight Holder, and Rod** - Counterweight Plate is affixed to the top of the expansion chamber using a threaded rod equipped with nuts. The nuts compress the top surface of the expansion chamber between the counterweight plate on top and the plate weight holder on the bottom. The rod is connected to the top of the gate. Expansion chamber Counterweight Plate is made of cast iron.
6. **Clamping Ring** - Clamps the bottom skirt of the expansion chamber to the circumference of the body, forming a water-tight seal. This seal prevents

waste water which enters the expansion chamber through the downstream port under surcharge conditions from leaking out of the expansion chamber.

7. **Cover** - Polyethylene cylinder which is positioned over the expansion chamber to protect it and constrain its expansion under surcharge conditions.
8. **Maintenance Handle** - Tee shaped handle used to attach to stem in center of counter weight plate to exercise valve during quarterly maintenance. The maintenance handle **MUST** be removed at the completion of required maintenance or the unit will not function properly.

FLOOD-GATE® ILLUSTRATION

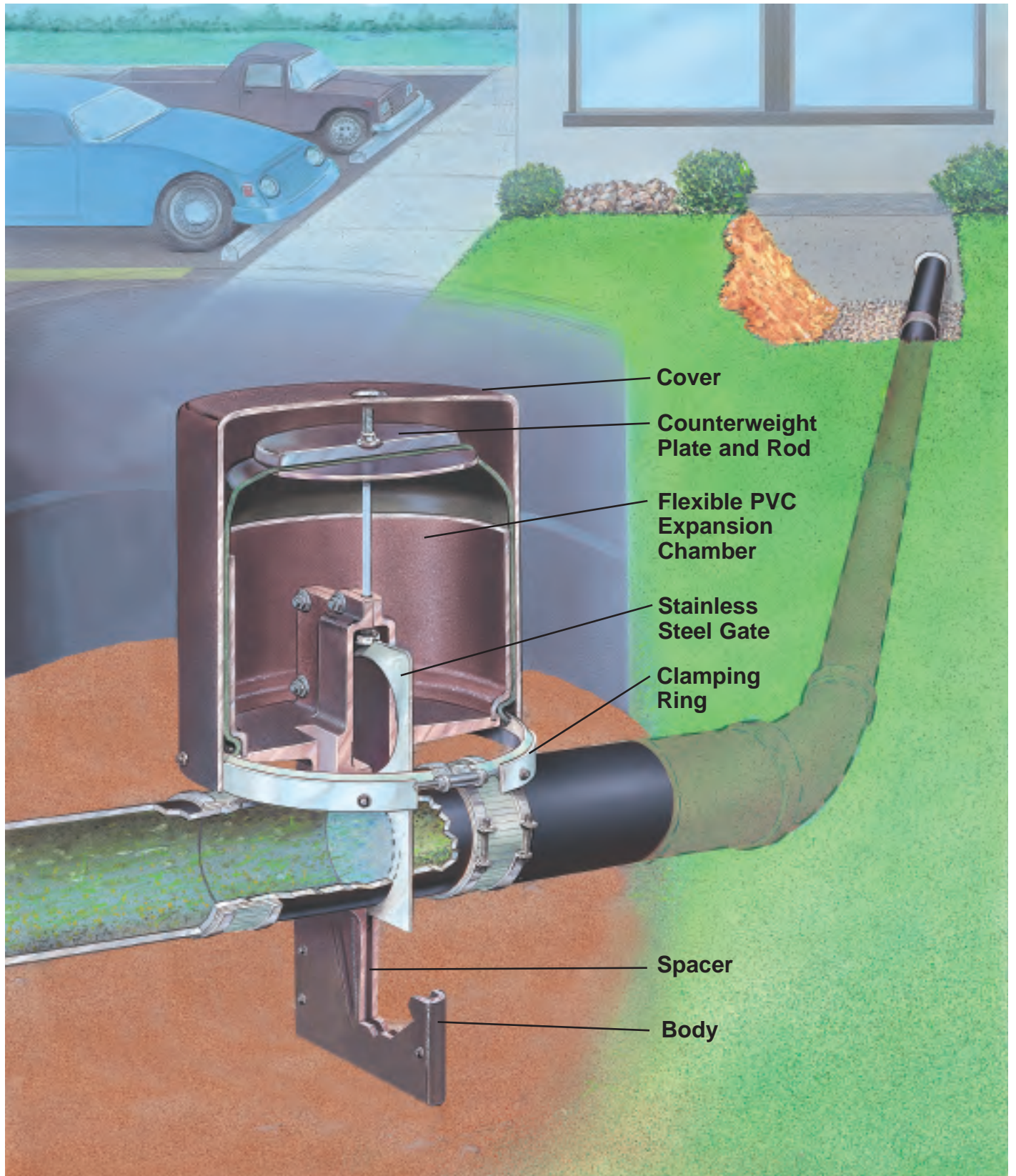

FLOOD-GATE® BACKWATER VALVE

IN-LINE AUTOMATIC BACKWATER VALVE

FUNCTION: Functions as a drainage control valve providing "closure" protection during emergency storm conditions or when building is completely shut down. The FLOOD-GATE® does not have to be activated as no electronics are required for valve operation. The valve is completely automatic both closing and resetting. Once closed it prevents any leakage beyond the gate. Applications include all commercial, institutional, residential and industrial installations including basements and elevator pits.

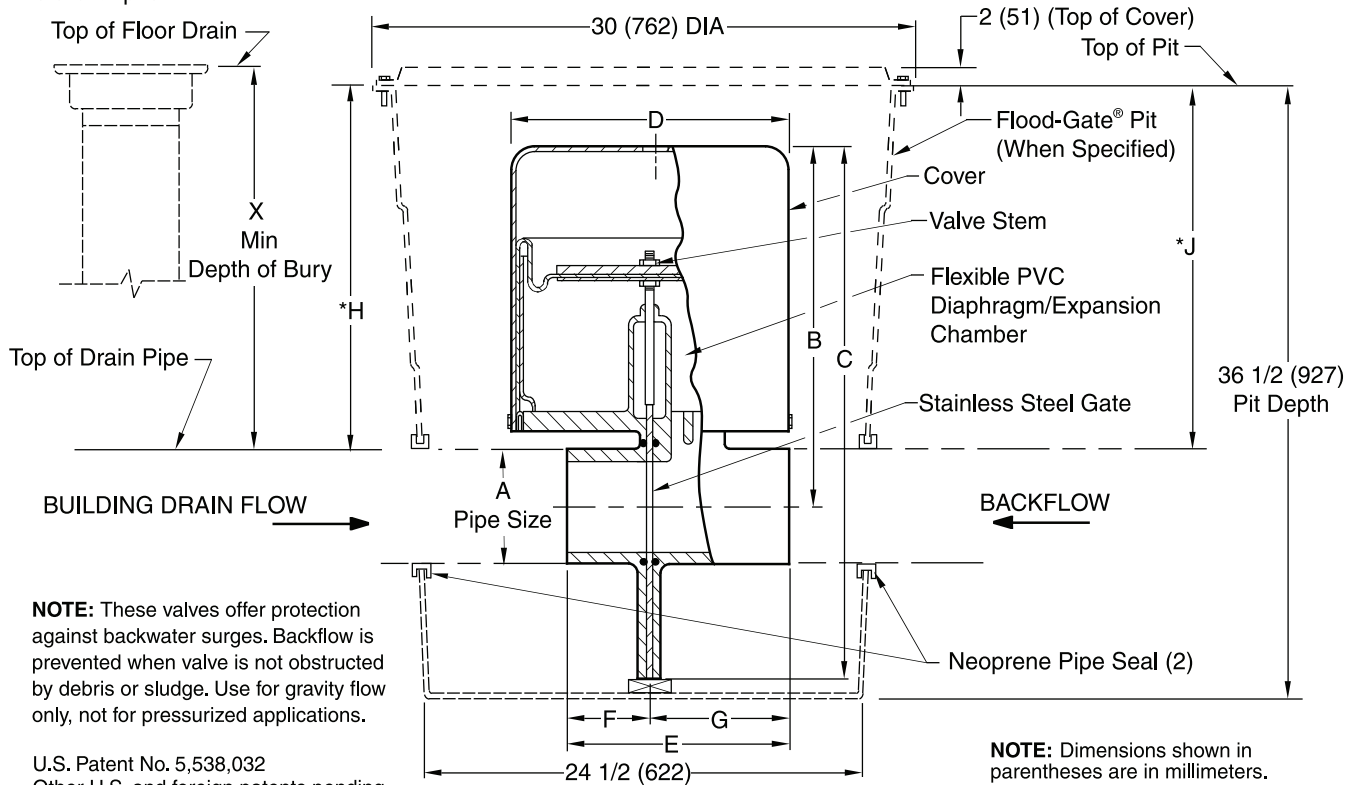

A DIA NO-HUB (-Y) IN/OUT SIZE	B CENTERLINE TO TOP	C OVERALL HEIGHT	D DIA WIDTH	E LENGTH	F INLET LENGTH	G OUTLET LENGTH	*H	*J	X MIN BURY DEPTH	BASE WIDTH
04 (100)	15 (380)	22 15/16 (583)	12 5/8 (321)	6 5/8 (168)	2 3/8 (60)	4 1/4 (110)	26 (660)	26 1/2(675)	9 (230)	7 1/2 (190)
06 (150)	20 3/8 (518)	31 1/4 (795)	13 1/4 (335)	8 3/16 (208)	3 3/16 (85)	5 (125)	22 (560)	22 1/2(570)	14 (355)	9 1/2 (240)

*Dimension can be decreased by up to 10 (254) for the 4 (100) size and 3 (76) for the 6 (150) size by cutting the pit and telescoping the 2 sections to meet required depth. See instructions supplied with pit.
See Operation & Maintenance Manual for required maintenance.

REGULARLY FURNISHED:

Duco Coated Cast Iron Body Complete with Stainless Steel Gate and Flexible PVC Diaphragm/Expansion Chamber.

VARIATIONS:

- Flood-Gate® Alarm
(-FGA, Alarm Control Box, Sensor and 35' Connecting Wire)
- Flood-Gate® Pits (**FOR NON TRAFFIC AREAS ONLY!**)
(-FGP, Poly Pit, Secured, Gasketed Poly Lid and Hardware)
(-FGS, Poly Pit, Secured, Gasketed Steel Cover and Hardware)
(-FGSL, Steel Cover only)

Conforms to ASME A112.14.1
IAPMO Listed, File No. 2696



JAY R. SMITH MFG. CO.®
DIVISION OF SMITH INDUSTRIES, INC.
POST OFFICE BOX 3237
MONTGOMERY, ALABAMA 36109-0237 (USA)
TEL: 334-277-8520 FAX: 334-272-7396 www.jrsmith.com



Visit www.jrsmith.com