



The new degree of comfort.™

C^oNTINUOUS

HOT WATER



Tankless Mid-Efficiency:

Rheem RTG series of ultra low NOx tankless gas water heaters

- 82% energy efficient with all copper heat exchanger
- Indoor direct vent and outdoor models
- For 3, 2 to 3 and 1 to 2 bathroom homes
- 12-Year limited warranty on heat exchanger

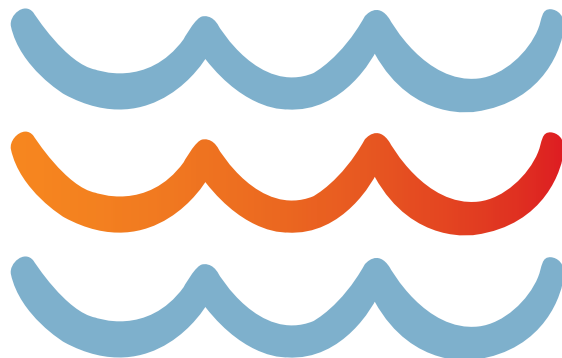

Get continuous hot water with the energy saving Rheem tankless mid-efficiency ultra low NOx indoor and outdoor models

Rheem uses sophisticated technology to create the most efficient whole home tankless water heating solution available from Rheem. The popularity of luxury bathrooms and oversize tubs is growing, and so is the demand for large volumes of low-cost hot water. Rheem's mid-efficiency tankless design offers unparalleled convenience and low-cost operation.

Efficiency

- 82% energy efficient with all copper heat exchanger
- Intelligent electronic controls designed to increase energy efficiency and safety
- Third party efficiency listed by AHRI

Performance

- Industry First! 0.26 GPM minimum flow rate, 0.40 GPM minimum activation flow rate
- RTG-95 for 3 bathroom homes* – 8.4 gal./min. at 35°F rise max., 8.4 gal./min. at 45°F rise
- RTG-84 for 2-3 bathroom homes* – 8.4 gal./min. at 35°F rise max., 6.6 gal./min. at 45°F rise
- RTG-64 for 1-2 bathroom homes* – 6.4 gal./min. at 35°F rise max., 5.6 gal./min. at 45°F rise

Compact Size

- Compact space saving design – about the size of a medicine cabinet

Self-Diagnostic System

- Self-diagnostic system for easy installation and service
- Digital display shows temperature setting and maintenance codes

High Altitude Compliant

- High-altitude capability – up to 9,840 ft. elevation above sea level

* Based on simultaneous showers using 2.5 gallons per minute. Flow rates vary depending on temperature of cold water supply.

Technology

- 3"/5" concentric vent system with Integrated condensate collector
- Hot start programming helps minimize fluctuation in water temperature, referred to as "cold water sandwich", during periods of frequent on/off operation
- Connects to Metal Fab. Inc., 3"/5" concentric venting without an adapter
- Built-in electric blower
- Exclusive! Guardian overhear film wrap (OFW)
- EZ-Link cable available for higher demand applications to connect two tankless units to operate as one
- Manifold up to six units with an optional MIC-6 manifold control board
- Manifold up to 20 units with the optional MIC-185 plus the MICS-180 manifold control assembly

Plus...

- Digital remote control and 10 ft. of thermostat wire included
- Supplied with a 120 volt power cord (indoor models only)
- Freeze protection to -30°F
- EZ- Spec™ Sizing Software – advanced online tool that takes the guess work out of sizing tankless applications – available at www.rheem.com/tankless

Warranty

- 12-Year on heat exchanger, 5-year on parts and 1-year on labor

See Residential Warranty Certificate for complete information



Commercial Applications

RTG Tankless Series can be upgraded for high-volume commercial use

- Temperature range is 85°F to 185°F

RTG-95 Upgrade Kits

- RTG20236A for RTG-95DVLN
- RTG20236B for RTG-95DVLP
- RTG20236C for RTG-95XLN
- RTG20236D for RTG-95XLP

RTG-84 Upgrade Kits

- RTG20237A for RTG-84DVLN
- RTG20237B for RTG-84DVLP
- RTG20237C for RTG-84XLN
- RTG20237D for RTG-84XLP

Note: These upgrade kits are not compatible with previous models. See the 2012 Tankless Parts Catalog for a complete listing.



LEED Points = 2

Superior Construction and Reliability

Venting Options and Installations

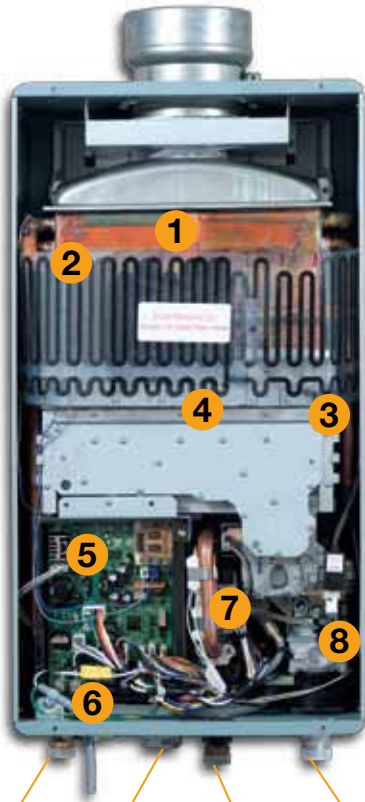

Indoor Direct Vent

- 1 All-Copper Heat Exchanger
- 2 Over Heat Film Wrap
- 3 Electronic Spark Ignition
- 4 150,000 - 199,900 Btu/h Modulating Burner
- 5 Electronic Control Board
- 6 Built-in Electric Blower
- 7 Water Flow Control System
- 8 Modulating Gas Valve



3\"/>

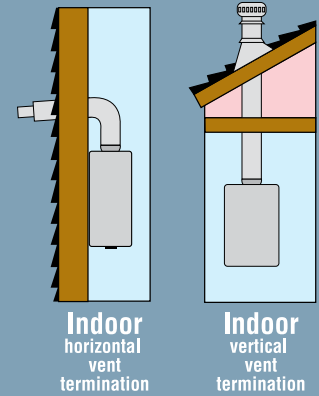

Indoor
horizontal
vent
termination

Indoor
vertical
vent
termination

All indoor tankless units must be vented vertically or horizontally to the outdoors using manufacturer approved venting material. See the installation instructions for each specific model. (ULCS636 Pipe must be used for Canada.)

3/4" Hot Water Outlet
External Connection for Remote Control Cable
3/4" Cold Water Inlet
3/4" Gas Connection

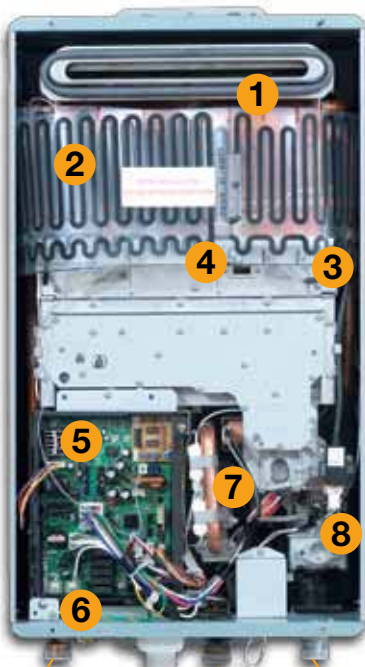

Outdoor

- 1 All-Copper Heat Exchanger
- 2 Over Heat Film Wrap
- 3 Electronic Spark Ignition
- 4 150,000 - 199,900 Btu/h Modulating Burner
- 5 Electronic Control Board
- 6 Built-in Electric Blower
- 7 Water Flow Control System
- 8 Modulating Gas Valve

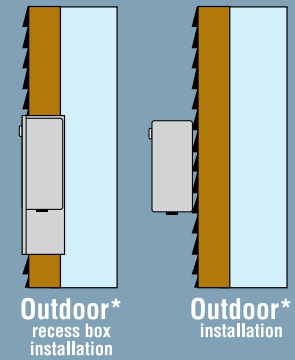

Outdoor*
recess box
installation

Outdoor*
installation

*Outdoor units do not require venting materials.

Venting details, including clearances and diagrams can be found in the "Use & Care Manual" of Rheem indoor tankless water heaters.

3/4" Hot Water Outlet
External Connection for Remote Control Cable
3/4" Cold Water Inlet
3/4" Gas Connection





The new degree of comfort.™



Residential Gas
Mid-Efficiency Tankless Water Heaters

Specifications

DESCRIPTION			FEATURES						ROUGHING IN DIMENSIONS (SHOWN IN INCHES)					ENERGY INFO.			
MODEL NUMBER	GAS INPUT BTU/H	TYPE	TEMP. RANGE	MIN. FLOW/ACTIVATION GPM	GPM @ 77° RISE MAX.	GPM @ 45° RISE MAX.	MAX. GPM	CONNECTION		HEIGHT	WIDTH	DEPTH	VENT DIAM.	SHIP. WEIGHT (LBS.)	ENERGY FACTOR	% OF THERM. EFFICIENCY	D.O.E. ANN. OP. COST NAT/LP
								WATER	GAS								
RTG-95 ULTRA LOW NO_x SERIES FOR 3 BATHROOM HOMES																	
RTG-95DVLN	11,000-199,900	Indoor Direct Vent	85° to 140° F*	0.26/0.40	4.3	7.4	9.5	3/4	3/4	25-5/8	13-7/8	9-7/8	3 by 5 CONCENTRIC	54	.82	82%	\$223/374
RTG-95XLN	11,000-199,900	Outdoor	85° to 140° F*	0.26/0.40	4.3	7.4	9.5	3/4	3/4	23-5/8	13-7/8	8-7/8	N/A	54	.82	82%	\$223/374
RTG-84 ULTRA LOW NO_x SERIES FOR 2-3 BATHROOM HOMES																	
RTG-84DVLN	11,000-180,000	Indoor Direct Vent	85° to 140° F	0.26/0.40	3.9	6.7	8.4	3/4	3/4	25-5/8	13-7/8	9-7/8	3 by 5 CONCENTRIC	54	.82	82%	\$223/374
RTG-84XLN	11,000-180,000	Outdoor	85° to 140° F	0.26/0.40	3.9	6.7	8.4	3/4	3/4	23-5/8	13-7/8	8-7/8	N/A	54	.82	82%	\$223/374
RTG-64 ULTRA LOW NO_x SERIES FOR 1-2 BATHROOM HOMES																	
RTG-64DVLN	11,000 - 150,000	Indoor Direct Vent	85° to 140° F	0.26/0.40	3.3	5.6	6.4	3/4	3/4	25-5/8	13-7/8	9-7/8	3 by 5 CONCENTRIC	54	.82	82%	\$223/374
RTG-64XLN	11,000 - 150,000	Outdoor	85° to 140° F	0.26/0.40	3.3	5.6	6.4	3/4	3/4	23-5/8	13-7/8	8-7/8	N/A	54	.82	82%	\$223/374

Energy Factor and Average Annual Operating Costs based on D.O.E. (Department of Energy) test procedures. D.O.E. national average fuel rate natural gas \$1.218/therm; LP \$1.87/gallon.

All models are available in Natural Gas and Propane (LP). For Propane replace the N with P when ordering.

- SCQAMD rule 1146.2 compliant.
- Factory set maximum temperature is 120° F. See Use and Care Manual for setting.
- Consult factory for information on sizing the application.
- Add a "C" to the model number when ordering Canadian models. Outdoor models are only for seasonal use in Canada. Please contact Rheem Canada Ltd. for details.

Vent Termination Kits are required for Direct Vent models. Contact your distributor for details.

Proper gas pressure must be ensured to supply tankless gas water heaters – up to 199,900 Btu/h for RTG-95 models, up to 180,000 Btu/h for RTG-84 models and up to 150,000 Btu/h for RTG-64 models. (Consult your gas supplier)

Temperature Rise (° F)

Model Number	35°	45°	50°	60°	70°	77°	80°	90°	100°
RTG-95 Water Flow (GPM)	9.5	7.4	6.6	5.5	4.7	4.3	4.1	3.7	3.3
RTG-84 Water Flow (GPM)	8.4	6.7	6.1	5.1	4.3	3.9	3.8	3.4	3.0
RTG-64 Water Flow (GPM)	6.4	5.6	5.1	4.2	3.6	3.3	3.2	2.8	2.5

Above estimates are for sizing purposes only.

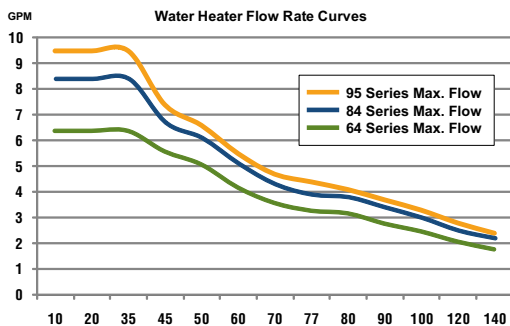

Maximum Vent Length (intake/outlet):

Number of 90° Elbows	Maximum Length of Straight Pipe
1	39.0 ft. (12.0 m)
2	37.5 ft. (11.5 m)
3	36 ft. (11 m)
4	34.5 ft. (10.5 m)
5	33.0 ft. (10.0 m)
6	31.5 ft. (9.5 m)

(Manufacturer approved venting required)

Indoor Direct Vent

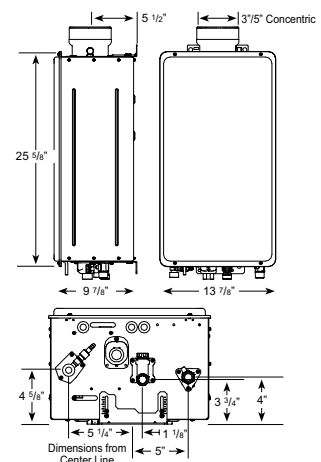

Outdoor

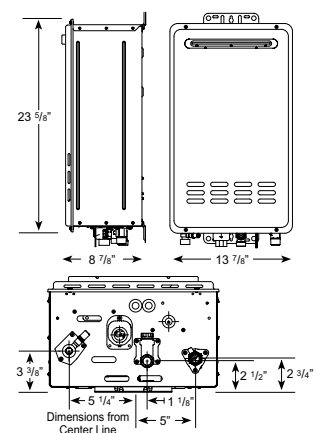

Parts and Accessories

Venting & terminations, recess boxes, pipe covers, extra remote controls, EZ-Link, manifolds and cables, service valve kits, service parts, flush kits

For more information on Tankless parts and accessories, see the Parts and Accessories catalog or call 866-720-2076.

In keeping with its policy of continuous progress and product improvement, Rheem reserves the right to make changes without notice.

Rheem Water Heating • 101 Bell Road
Montgomery, Alabama 36117-4305 • 1.800.621.5622

Rheem Canada Ltd./Ltée • 125 Edgeware Road, Unit 1
Brampton, Ontario L6Y 0P5 • 1.800.268.6966



INTEGRATED AIR & WATER

Rheem.com

PRINTED IN U.S.A. 05/12 WP FORM NO. TK-95 Rev. 3