

Air Filter

LintBuster™

The air filter and scrubber with vacuum that removes lint, dust and contaminants from the air

CHICAGO®



**Standard
Full Size**



LoPro

Now Available in Two Models to Fit the Needs of Any Laundry Space

Chicago now offers these great auxiliary items to help remove lint from the area around an Air Chicago towel folder, Skyline sheet, blanket, or table linen folder or Skyline Mini blanket and pad folder, as well as Chicago ironers. They are designed to scrub and capture airborne lint to improve air quality for operators, improve equipment performance by keeping mechanical equipment and electronic sensors cleaner, and generally reduce the amount of blow down and clean up time required of maintenance staff. Unit also comes standard with a remote control to turn it on and off from floor level. On new installations, power connections and supporting stands can also be provided on Chicago finishing equipment to reduce installation cost and provide a cleaner look, as well as a cleaner laundry. (Consult factory for details.)

LintBuster

Dimensions and Utilities

NOTE:

1. Specifications subject to change without notice. Consult factory for certified construction floorplan.
2. Millimeter dimensions are in [].
3. All dimensions are +/- 1/2".
4. Electrical Requirements: 1/60/208-230, 11.5A

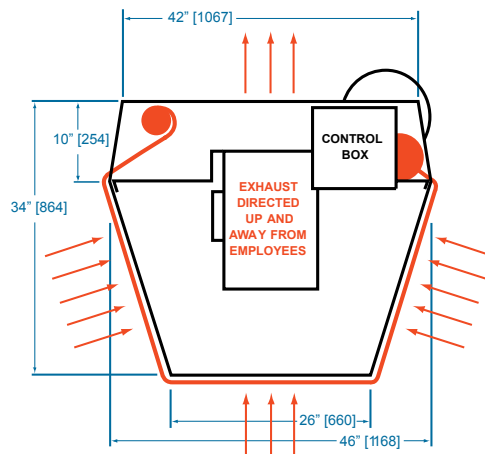

Weight - Standard Unit 320 lb.

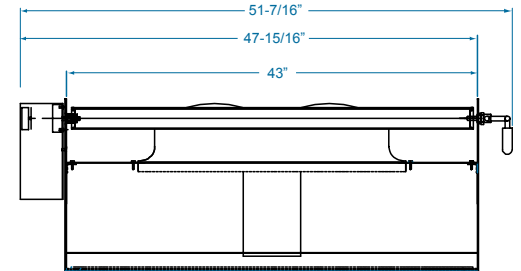
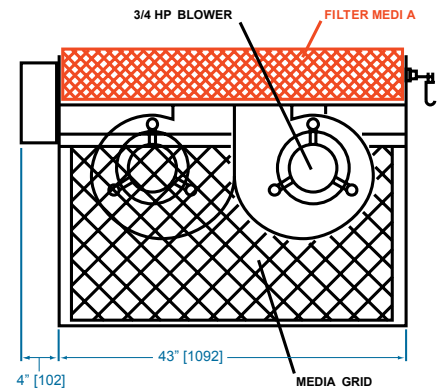
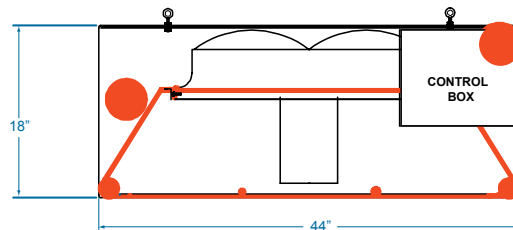

Weight - LoPro Unit 180 lb.

Features

LintBuster easily positions over finishing equipment that creates secondary lint and dust as it process textiles

CAPACITY

LintBuster utilizes two 3/4 HP vacuum blowers and LintBuster LoPro utilizes one 1/2 HP vacuum blower to draw the lint filled air past filter media of 200 micron that layers the lint onto the surface of the media.

PRODUCTION

Reliable pressure transducer control technology automatically rolls up clogged filter media, while advancing clean filter media into operating position

Consistent vacuum suction is always maintained over the working area so lint and dust created by flatwork processing is continuously extracted

Employee area is cleaner and air quality is better

Reduces lint accumulation on electronic sensors to improve equipment reliability

MAINTENANCE SAVINGS

Saves on daily required maintenance labor of feeding and folding equipment by reducing manual cleaning and compressed air blow down of lint from and around expensive feeding, ironing and folding equipment

High strength, non-corrosive aluminum alloy construction

Shipped completely assembled, UL approved, ready to hang, plug in and start collecting lint

Available in single phase 208V or 230V.

Consult factory for optional support stand to attach LintBuster directly to folder or other equipment.

A Complete Range of Separating, Feeding, Ironing, Folding, and Sorting Options

Because Chicago specializes only in flatwork finishing equipment, it can offer the world's widest range of high production separating, feeding, ironing, folding and sorting equipment. Complete flatwork finishing systems range from automated multi-roll systems producing over 2000 pounds per hour, to compact ironers for small on-premise laundries.

Chicago's performance record is unmatched in thousands of installations in commercial, hospitality, health care, textile rental, institutional and on-premise laundries all over the world. An experienced Chicago professional will be pleased to make an objective

equipment recommendation based on your production, space, utility and budget requirements. Contact your local Chicago distributor or the factory sales assistance office for a no-obligation analysis of your needs.

Chicago's Customer Service department offers full technical and service support by telephone and on our website. We also offer overnight service for quick parts availability. Visit our website, www.chidry.com, to learn more about our complete line of flatwork finishing systems, including video of Chicago® equipment in action.



CHICAGO DRYER COMPANY
2200 North Pulaski Road
Chicago, Illinois 60639-3737 USA

Phone • 773.235.4430
Fax • 773.235.4439
Web • www.chidry.com
Email • chicago@chidry.com