

## Water Feeders – Make-Up

### Series 551-S Make-Up Water Feeder



- For applications where water is added to steam separators, receivers, tanks, or other vessels
- Proportional feed action
- Quick-change replaceable cartridge valve and strainer
- Optional features
  - Float Block
- Maximum water supply pressure 75 psi (5.3 kg/cm<sup>2</sup>)
- Maximum inlet water temperature 120°F (49°C)
- Maximum vessel pressure 25 psi (1.8 kg/cm<sup>2</sup>)



551-S

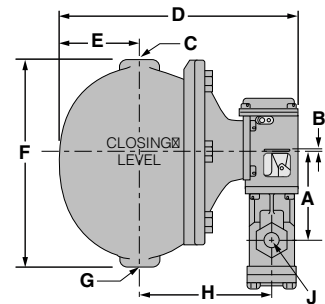

### Dimensions, in. (mm)

A	B	C NPT	D	E	F	G NPT	H	J NPT
4 <sup>5</sup> / <sub>8</sub> (117)	1 <sup>1</sup> / <sub>8</sub> (3.2)	1	12 <sup>1</sup> / <sub>4</sub> (311)	4 <sup>1</sup> / <sub>8</sub> (105)	10 <sup>3</sup> / <sub>8</sub> (264)	1	6 <sup>11</sup> / <sub>16</sub> (170)	3 <sup>3</sup> / <sub>4</sub>

### Ordering Information

Model Number	Part Number	Description	Weight lbs. (kg)
551-S	136400	Make-up water feeder	35.8 (16.2)
551-SB	136500	551-S w/float block	35.8 (16.2)

### Capacities

