

NON-ELECTRIC CONDENSATE PUMPS

PMPSP "The Pit Boss"

Watson McDaniel reserves the right to change the designs and/or materials of its products without notice.
©2010 Watson McDaniel Company

Sump Drainer

PUMPS

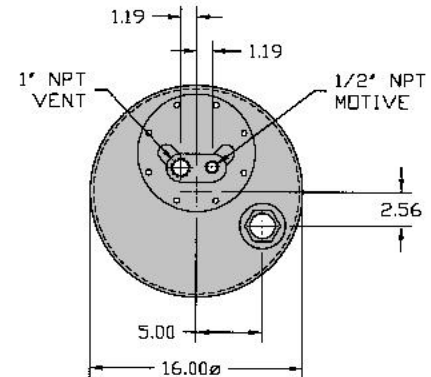

Model	PMPSP
Body	Carbon Steel
Cover	Ductile Iron
Check Valves	Stainless Steel
PMO Max. Operating Pressure	150 PSIG
TMO Max. Operating Temperature	366°F
PMA Max. Allowable Pressure	150 PSIG @ 650°F

Connection Sizes NPT	
Inlet	Outlet
1 1/2"	1 1/2"
2"	2"
3"	2"

TYPICAL APPLICATIONS

The **PMPSP** Sump Drainer uses the identical internal mechanism as the standard PMP models. The piping configuration is such that the liquid is discharged vertically upwards as opposed to horizontally out the side. This allows the unit to be easily positioned inside of a sump area. Condensate or water from the sump enters the tank through a stainless steel low resistance check valve.

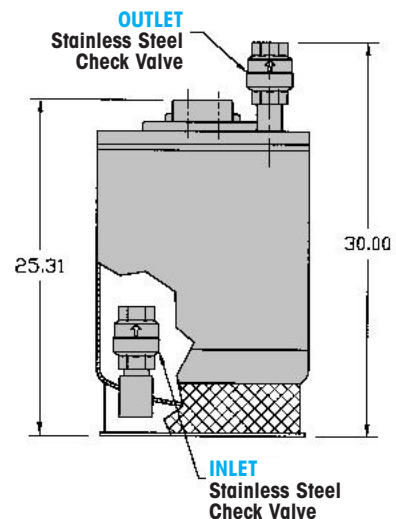

FEATURES

- Equipped with our Patented "Snap-Assure" Mechanism which extends the useful life of the pump
- Mechanism incorporates heat-treated stainless steel wear items
- All stainless steel internals for ultimate corrosion resistance
- Dual compression springs made from Inconel-X-750 for high-temperature corrosive service
- Operates using steam, air, nitrogen or other pressurized gases as the motive force
- **Non-Electric** – can be used in remote locations or NEMA 4, 7, 9 & hazardous areas
- Built-in strainer screen

NON-ELECTRIC CONDENSATE PUMPS

PMPSP

Sump Drainer

PUMPS

"The Pit Boss"

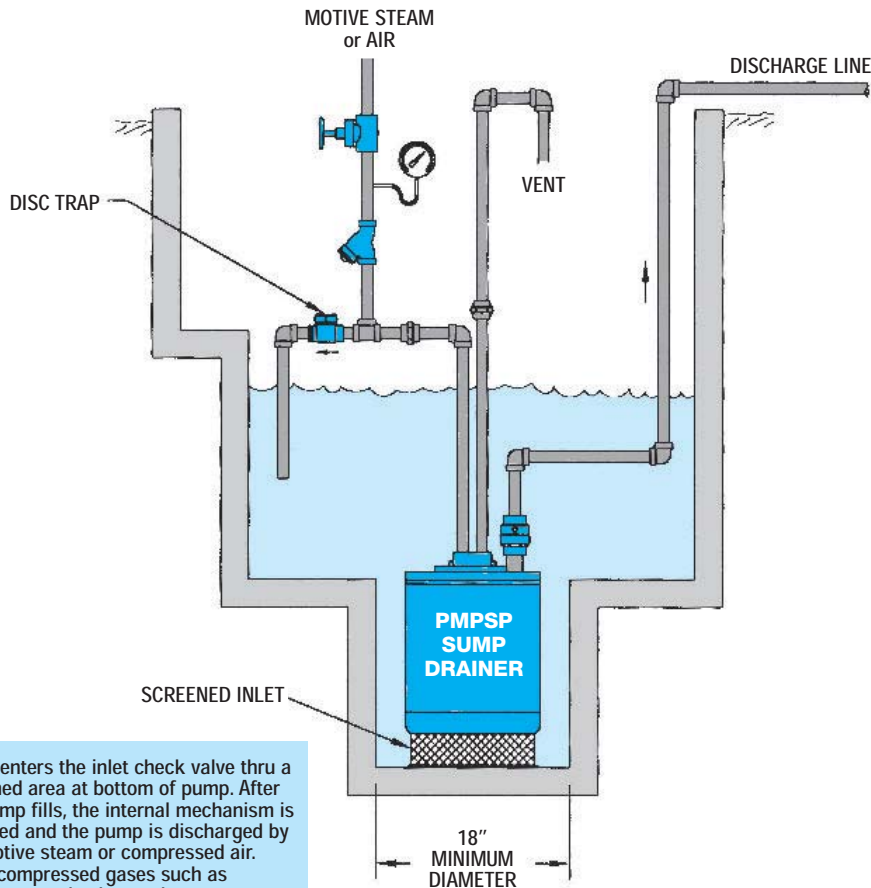

Water enters the inlet check valve thru a screened area at bottom of pump. After the pump fills, the internal mechanism is actuated and the pump is discharged by the motive steam or compressed air. Other compressed gases such as nitrogen can also be used.

CAPACITIES – Water (GPM) for 1 1/2" x 1 1/2" Size								
Motive Pressure (PSIG)	Capacity Correction Factors		Back Pressure (PSIG)					
	2" x 2"	3" x 2"	0	10	20	40	70	100
10	2.5	3	11.7					
20	1.8	2.4	12.5	9.2				
40	1.9	2.4	13.1	10.4	8.7			
70	1.7	2.4	12.9	11.0	9.4	7.1		
100	1.6	2	12.3	10.6	9.4	7.5	5.4	
125	1.6	2	11.6	10.1	9.0	7.5	5.6	4.3
150	1.6	2	10.7	9.5	8.8	7.2	5.7	4.5

Note: Capacities in above chart are for the 1-1/2" x 1-1/2" model. To determine capacities for the 2" x 2" & 3" x 2" models, multiply capacity in chart by appropriate correction factor.

Snap-Assure Patent No. 6572340