

WILKERSON®

08, 18 and 28 Series FRL Products

Compact, Intermediate & Standard Modular Air Preparation Systems

Catalog 605

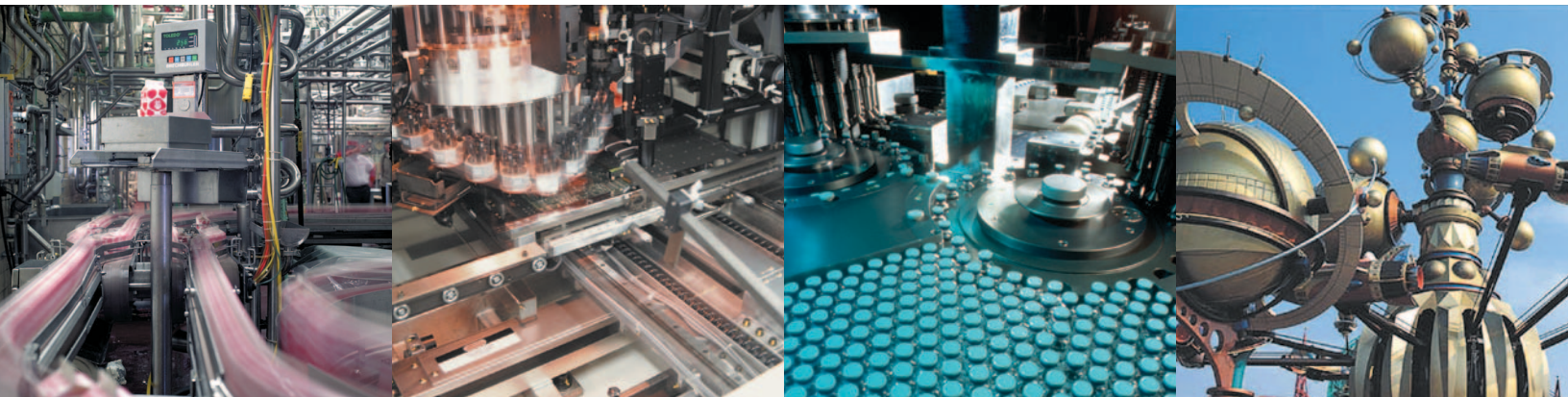

the total systems approach to air preparation

WILKERSON®

First incorporated in August of 1948, Wilkerson manufactures a complete line of compressed air treatment and control products to meet a wide variety of applications. Today, Wilkerson serves over 500 different industries throughout the world.

Over the years, Wilkerson facilities, manufacturing and engineering technology have kept pace with increased sales volume, the growing need to satisfy customers' specific requirements and the demands placed on production.

Wilkerson's growing leadership in the industry is due to our determined commitment to quality; quality of

products, services and people. Our dedication to the total quality management process assures our customers that we can consistently provide the highest levels of product quality and customer service needs.

From the very beginning, Wilkerson has sold its products through a world-wide, independent distributor network. We currently have 200 distributors throughout North America, plus an expanding network of international distributors in over 40 countries. Our distributors, with many years of experience in compressed air treatment and control, offer excellent product

knowledge, technical assistance and local inventory. As a result of representing other complimentary products, they are able to satisfy their customers' total requirements.

Today's broad line of Wilkerson products is the result of continuing product innovations and technology advancements which frequently become industry standards. Wilkerson is dedicated to designing and manufacturing innovative products with features and operating characteristics that meet customer requirements for quality, performance, reliability, serviceability, safety and value.

WARNING

FAILURE OR IMPROPER SELECTION OR IMPROPER USE OF THE PRODUCTS AND/OR SYSTEMS DESCRIBED HEREIN OR RELATED ITEMS CAN CAUSE DEATH, PERSONAL INJURY AND PROPERTY DAMAGE.

This document and other information from The Company, its subsidiaries and authorized distributors provide product and/or system options for further investigation by users having technical expertise. It is important that you analyze all aspects of your application including consequences of any failure, and review the information concerning the product or system in the current product catalog. Due to the variety of operating conditions and applications for these products or systems, the user, through its own analysis and testing, is solely responsible for making the final selection of the products and systems and assuring that all performance, safety and warning requirements of the application are met.

The products described herein, including without limitation, product features, specifications, designs, availability and pricing, are subject to change by The Company and its subsidiaries at any time without notice.

Offer of Sale

The items described in this document are hereby offered for sale by The Company, its subsidiaries or its authorized distributors. This offer and its acceptance are governed by the provisions stated on the separate page of this document "Offer of Sale".

Compact Modular	
08 Series.....	2
Accessories & Options	3-4
Dimensions	5
Specifications & Ordering Data	6-7
Flow Charts.....	8
Intermediate Modular	
18 Series.....	9-10
Accessories & Options	11-12
Dimensions	13
Specifications & Ordering Data	14-15
Flow Charts.....	16
Standard Modular	
28 Series.....	9-10
Accessories & Options	11-12
Dimensions	17
Specifications & Ordering Data	18-19
Flow Charts.....	20
Total Systems Approach.....	21
Materials of Construction	22
Safety Guidelines	23-24
Offer of Sale	25

COMPACT MODULAR 08 SERIES



Filter

The F08 compact filter features a 5 micron particulate element, quick disconnect plastic bowl with bowl guard and a manual pipe away type manual drain. Quick disconnect metal bowls and piston automatic drains are additional available options. Wilkerson F08 filters meet or exceed ISO class 3 for maximum particle size retention and removal.



Regulator

The R08 compact regulator features a balanced valve for superior regulation characteristics, two gauge ports, and a bottom plug for ease of maintenance serviceability. The unique flush-mounted pressure gauge is available as an option.



Coalescing Filter

The M08 compact coalescing filter provides high efficiency removal of water, oil aerosols and solid particulate contaminants down to .01 micron in size. The M08 comes standard with quick disconnect plastic bowl with bowl guard and a manual pipe away type manual drain. Quick disconnect metal bowls and piston automatic drains are additional available options.



Lubricator

The L08 compact lubricator features an integral clear sight dome and adjustment knob for quick setting of the lubrication rate. The L08 can also be replenished with oil while under pressure by using the 1/8" fill plug at the top of the unit.



Filter / Regulator

The B08 compact integral filter / regulator combines all the advanced features and functions of the standard filter and regulator into a single, space saving, high performance unit.



Filter / Regulator - Lubricator Combination

The D08 compact modular combination model brings together all the superior features and functions of the 08 series modular FRL product line into a compact, lightweight assembly.

COMPACT MODULAR 08 SERIES

ACCESSORIES AND OPTIONS



Diverter Block

For increased design flexibility, the N08 diverter block is available with 1/4" threaded inlet / outlet ports. The diverter block can be mounted anywhere in the FRL system. The unit comes with two, 1/4" or 1/8" threaded auxiliary ports.



Modular Lockout Valve

The V40 modular lockout valve is a 40mm ball valve style with the ability to modularly mount into any standard 08 series assembly. It provides shut off line pressure with a non-sticking 90° turn handle to prevent unauthorized adjustment.



Safety Lockout Valve

The V08 safety lockout valve is a manually operated slide-type 3-way valve. In the closed position downstream air is exhausted to atmosphere. The valve slide can be locked in the closed position with a customer supplied padlock. (Meets OSHA Reg 29 CFR Part 1910)



Combined Soft Start / Dump Valve

The E09 series combined soft start / dump valve provides for the safe introduction of pressure to machines or systems. Soft start / dump valves when set, allow the pressure to gradually build to the set point before fully opening to deliver full flow at line pressure.



Metal Bowl and Automatic Piston Drain

The 08 series has both optional metal bowl and automatic cyclic piston drain to meet your application needs.



Dump Valve

The Q09 series dump valves 3-way, 2-position function automatically dumps downstream pressure on the loss of pilot signal. It features both solenoid or air pilot options. Silencer included.



Flush Mount Pressure Gauge

The 08 series Regulator features an attractive, square-housing, flush mount pressure gauge (0-160 PSIG) that can be mounted on either side of the regulator for piping convenience. Standard 1/8" NPT gauge ports and gauges are also available.



Proportional Pressure Regulators

The ER09 proportional pressure regulators provide all the advantages of a closed circuit regulated system. When a set value is defined via the input signal (e.g. 0-10 V), the pressure regulator sets the corresponding output pressure (e.g. 0-150 PSI / 0-10 bar). At the same time the integrated pressure sensor measures the actual pressure at the unit's outlet (actual value).

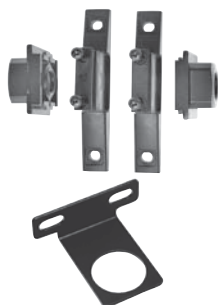

Modular Brackets and Joiner Assembly

A wide choice of unit mounting brackets and joiner assemblies allow for easy unit installation, assembly, and mounting.

COMPACT MODULAR 08 SERIES

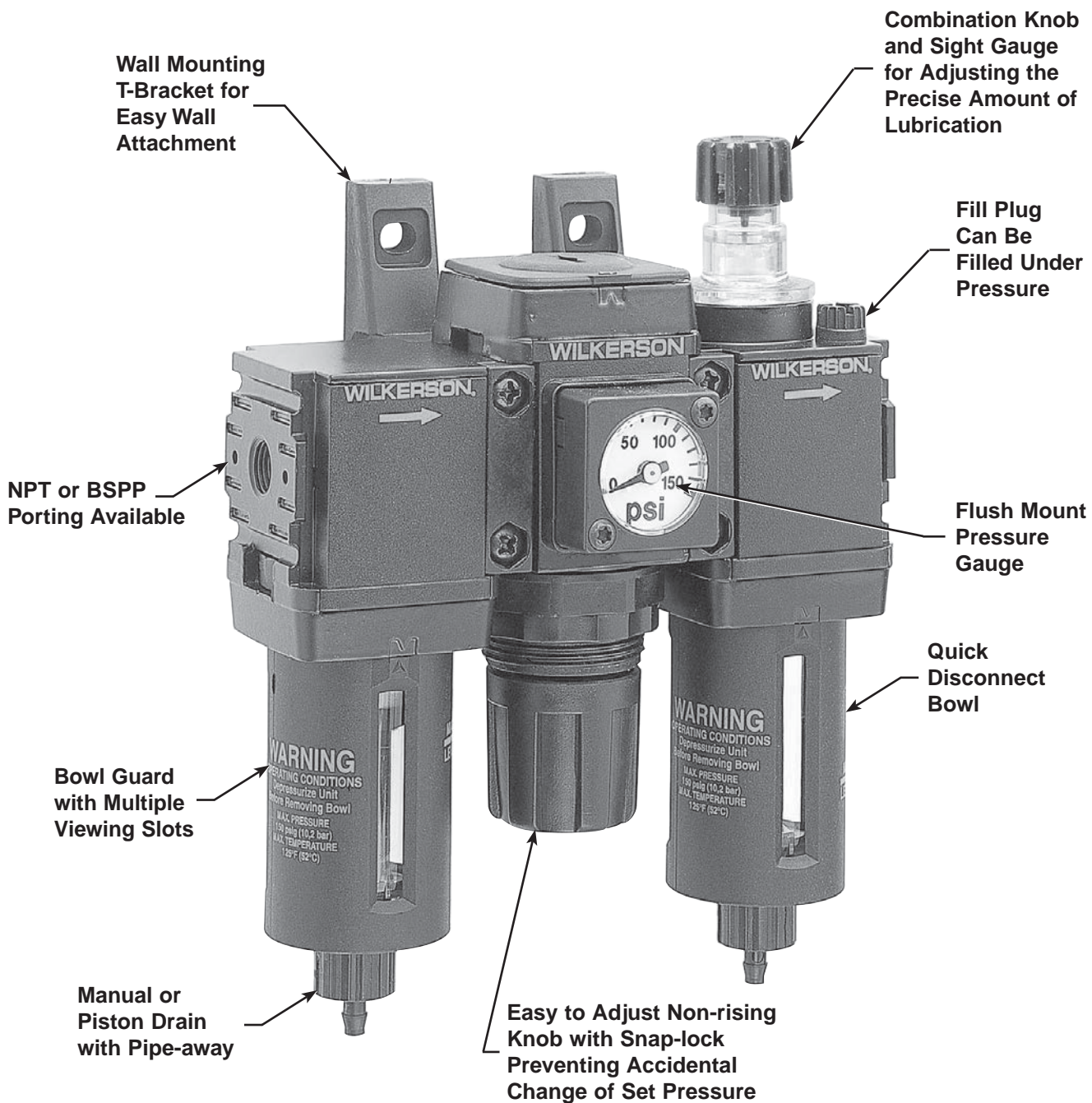

Filter / Regulator / Lubricator Combination Units

The C08 modular FRL combination model integrates components of the advanced "08" product line into a compact, lightweight, ready-to-mount assembly. The units come standard with pressure gauge and are

pre-assembled utilizing our modular T-bracket / joiner assembly for easy installation and mounting.

COMPACT MODULAR 08 SERIES

DIMENSIONAL DRAWINGS

Inches
(mm)

F08 & M08

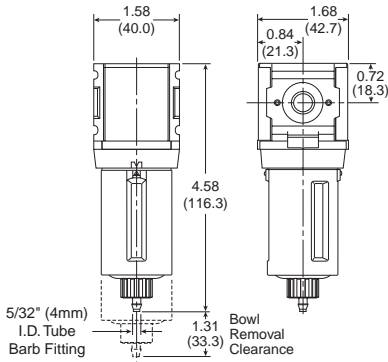

R08

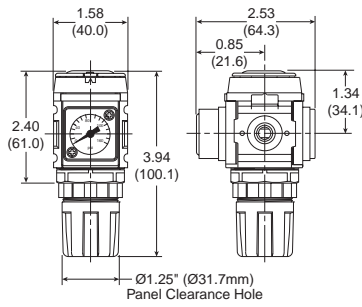

L08

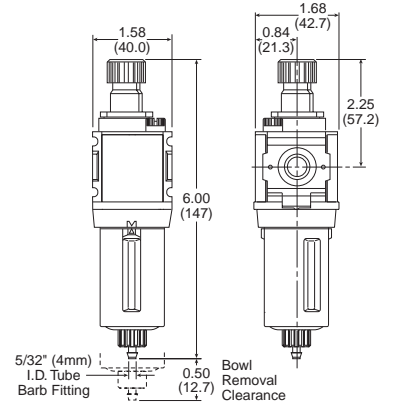

B08

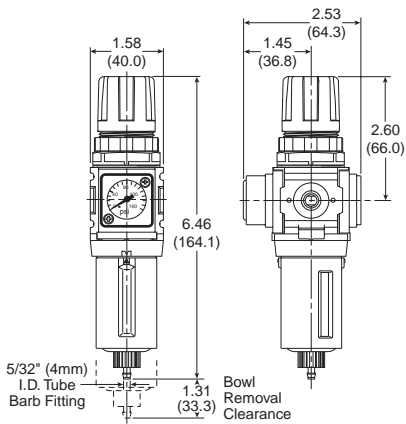

D08

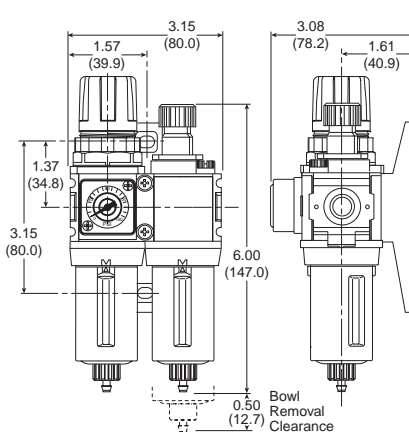

C08

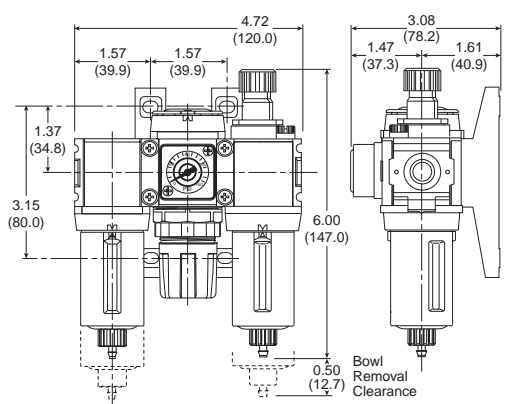

ER09

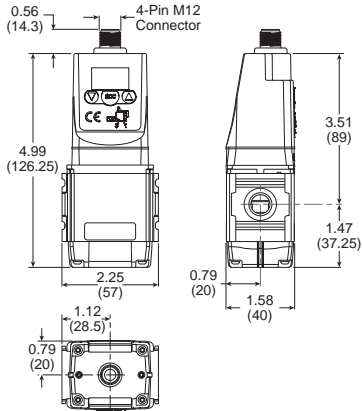

E09 / Q09

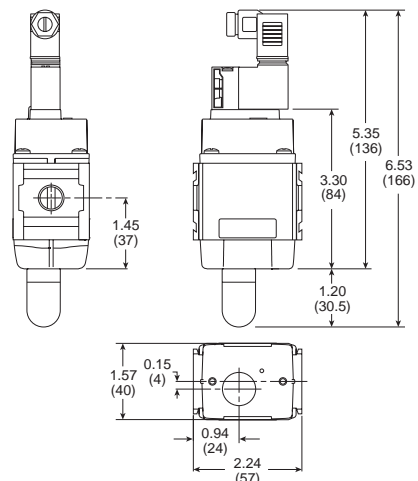

V08

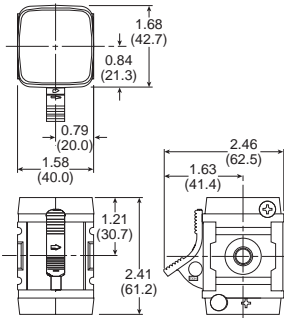

V40

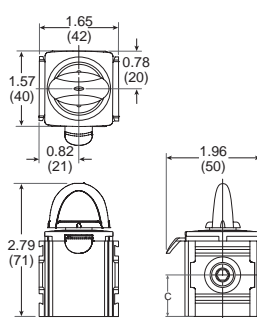

N08

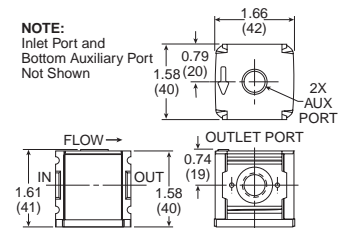

NOTE:
Inlet Port and
Bottom Auxiliary Port
Not Shown

COMPACT MODULAR 08 SERIES

SPECIFICATIONS AND ORDERING DATA

Model No.	Description	Pipe Size NPT	Flow SCFM	Max. Pressure PSIG	Max. Temp. °F	Bowl Capacity oz.	Height inches	Width inches	Depth inches	Weight lbs.
FILTERS* – PLASTIC BOWL WITH BOWL GUARD										
F08-01-SK00	Manual Drain	1/8	25.0	150	125°	0.4	4.58	1.58	1.68	0.5
F08-02-SK00	Manual Drain	1/4	50.0	150	125°	0.4	4.58	1.58	1.68	0.5
F08-01-SR00	Automatic Piston Drain	1/8	25.0	150	125°	0.4	4.58	1.58	1.68	0.5
F08-02-SR00	Automatic Piston Drain	1/4	50.0	150	125°	0.4	4.58	1.58	1.68	0.5

COALESCING FILTERS* – PLASTIC BOWL WITH BOWL GUARD										
M08-02-BK00	Coalescing / Manual Drain / 0.5 Micron	1/4	11.0	150	125°	0.4	4.58	1.58	1.68	0.4
M08-02-BR00	Coalescing / Automatic Piston Drain / 0.5 Micron	1/4	11.0	150	125°	0.4	4.58	1.58	1.68	0.4
M08-02-CK00	Coalescing / Manual Drain / 0.01 Micron	1/4	11.0	150	125°	0.4	4.58	1.58	1.68	0.4
M08-02-CR00	Coalescing / Automatic Piston Drain / 0.01 Micron	1/4	11.0	150	125°	0.4	4.58	1.58	1.68	0.4
M08-02-DK00	Coalescing / Manual Drain / Activated Carbon	1/4	11.0	150	125°	0.4	4.58	1.58	1.68	0.4
M08-02-DL00	Coalescing / Manual Drain, Metal Bowl / Activated Carbon	1/4	11.0	150	125°	0.4	4.58	1.58	1.68	0.4

REGULATORS* – 0-125 PSI ADJUSTMENT RANGE										
R08-01-F000	Relieving	1/8	29.2	300	150°	—	3.94	1.58	—	0.7
R08-01-F0G0	Relieving / Gauge	1/8	29.2	300	150°	—	3.94	1.58	2.53	0.7
R08-02-F000	Relieving	1/4	44.0	300	150°	—	3.94	1.58	—	0.7
R08-02-F0G0	Relieving / Gauge	1/4	44.0	300	150°	—	3.94	1.58	2.53	0.7

LUBRICATORS* – PLASTIC BOWL WITH BOWL GUARD										
L08-01-KK00	Manual Drain	1/8	23.5	150	125°	0.6	5.65	1.58	1.68	0.6
L08-02-KK00	Manual Drain	1/4	57.5	150	125°	0.6	5.65	1.58	1.68	0.6

FILTER / REGULATORS* – PLASTIC BOWL WITH BOWL GUARD, 0-125 PSI ADJUSTMENT RANGE										
B08-01-FK00	Relieving	1/8	28.6	150	125°	0.4	6.46	1.58	—	0.8
B08-01-FKG0	Relieving / Gauge	1/8	28.6	150	125°	0.4	6.46	1.58	2.53	0.8
B08-01-FRG0	Relieving / Piston Drain / Gauge	1/8	28.6	150	125°	0.4	6.46	1.58	2.53	0.8
B08-02-FK00	Relieving	1/4	42.1	150	125°	0.4	6.46	1.58	—	0.8
B08-02-FKG0	Relieving / Gauge	1/4	42.1	150	125°	0.4	6.46	1.58	2.53	0.8
B08-02-FRG0	Relieving / Piston Drain / Gauge	1/4	42.1	150	125°	0.4	6.46	1.58	2.53	0.8

3-UNIT COMBINATIONS* – PLASTIC BOWL WITH BOWL GUARD, 0-125 PSI ADJUSTMENT RANGE, FLUSH MOUNT PRESSURE GAUGE										
C08-01-FKG0	Filter + Regulator + Lubricator / Manual Drain	1/8	28.7	150	125°	—	6.46	4.74	—	2
C08-02-FKG0	Filter + Regulator + Lubricator / Manual Drain	1/4	40.0	150	125°	—	6.46	4.74	—	2
C08-01-FRG0	Filter + Regulator + Lubricator / Automatic Piston Drain	1/8	28.7	150	125°	—	6.46	4.74	3.08	2
C08-02-FRG0	Filter + Regulator + Lubricator / Automatic Piston Drain	1/4	40.0	150	125°	—	6.46	4.74	3.08	2

*Unit models are available in BSPP by placing a "C" in the 4th position of the unit model number.

COMPACT MODULAR 08 SERIES

SPECIFICATIONS AND ORDERING DATA

Model No.	Description	Pipe Size NPT	Flow SCFM	Max. Pressure PSIG	Max. Temp. °F	Height inches	Width inches	Depth inches	Weight lbs.
2-UNIT COMBINATIONS* – PLASTIC BOWL WITH BOWL GUARD, 0-125 PSI ADJUSTMENT RANGE, FLUSH MOUNT PRESSURE GAUGE									
D08-01-FKG0	Filter / Regulator + Lubricator / Manual Drain	1/8	28.6	150	125°	6.46	3.15	—	1.4
D08-02-FKG0	Filter / Regulator + Lubricator / Manual Drain	1/4	42.1	150	125°	6.46	3.15	—	1.4
D08-01-FRG0	Filter / Regulator + Lubricator / Automatic Piston Drain	1/8	28.6	150	125°	6.46	3.15	3.08	1.4
D08-02-FRG0	Filter / Regulator + Lubricator / Automatic Piston Drain	1/4	42.1	150	125°	6.46	3.15	3.08	1.4

OPTIONS, ACCESSORIES AND KITS									
K4511SCR150	Gauge 0-150 psi / Square Face	—	—	—	—	1.06	0.59	—	0.05
K4511SCR060	Gauge 0-60 psi / Square Face	—	—	—	—	1.06	0.59	—	0.05
GPA-97-018	End Port Block Set (Contains both ends and joiners)	1/8	—	—	—	1.42	0.31	—	0.33
GPA-97-019	End Port Block Set (Contains both ends and joiners)	1/4	—	—	—	1.42	0.31	—	0.33
GPA-97-025	End Port Block Set (Contains both ends and joiners) / T-Bracket	1/8	—	—	—	1.57	1.42	—	0.41
GPA-97-026	End Port Block Set (Contains both ends and joiners) / T-Bracket	1/4	—	—	—	1.57	1.42	—	0.41
RPA-96-733	Panel Mount Nut (Aluminum)	—	—	—	—	—	—	—	—
RPA-96-734	Panel Mount Nut (Plastic)	—	—	—	—	—	—	—	—
GPA-96-738	Modular Joiner Set	—	—	—	—	1.42	0.39	—	0.02
GRP-96-739	L-Type Bracket	—	—	—	—	0.97	2.68	—	0.05
GPA-96-010	C-Type Bracket	—	—	—	—	2.67	2.32	—	0.09
GPA-96-737	Modular Joiner Set / T-Type Bracket	—	—	—	—	3.97	0.64	—	0.09
FRP-96-729	5 Micron Element Kit - For use with F08 / B08	—	—	—	—	—	—	—	—
MSP-96-732	.5 Micron Element Kit - For use with M08	—	—	—	—	—	—	—	—
MTP-96-649	.01 Micron Element Kit - For use with M08	—	—	—	—	—	—	—	—
MXP-96-222	Activated Carbon Element Kit - For use with M08	—	—	—	—	—	—	—	—
GRP-96-712	Plastic Bowl / Bowl Guard / Manual Drain	—	—	—	—	—	—	—	—
GRP-96-714	Metal Bowl Manual Drain	—	—	—	—	—	—	—	—
GRP-96-716	Automatic Piston Drain Kit	—	—	—	—	—	—	—	—

OTHER PRODUCTS									
V08-02-0000	Safety Lockout Valve	1/4	80.0	150	150°	2.41	1.58	2.46	0.66
V40-02-B000	Safety Lockout Valve – Ball Style	1/4	42.0	246	150°	2.79	1.65	1.96	0.41
N08-02-0000	Diverter Block	1/4	140.0	300	150°	1.61	1.66	1.58	0.42
Q09-02-EC00	Dump Valve - 24VDC, 15mm Coil	1/4	36.0	150	122°	6.53	2.24	1.57	0.90
E09-02-EC00	Combined Soft-Start Dump Valve	1/4	17.0	150	122°	6.53	2.24	1.57	0.98
ER09-02-EC00	Electronic Proportional Regulator	1/4	40.0	152	122°	5.55	2.25	1.58	0.64

Metal bowl manual drain use L in 7th position XXX-XX-XLXX

Metal bowl piston drain use S in 7th position XXX-XX-XSXX

Metal bowl increases Max. Pressure to 250 PSIG, Max. Temp. to 150°F.

*Unit models are available in BSPP by placing a "C" in the 4th position of the unit model number.

COMPACT MODULAR 08 SERIES

FLOW CHARTS

Note: Regulator flow data based on inlet pressure = 100 PSIG, all others = 150 PSIG

F08 / M08 / R08

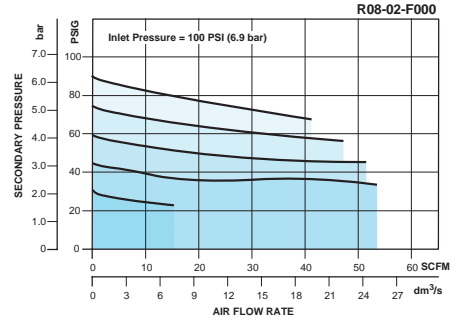
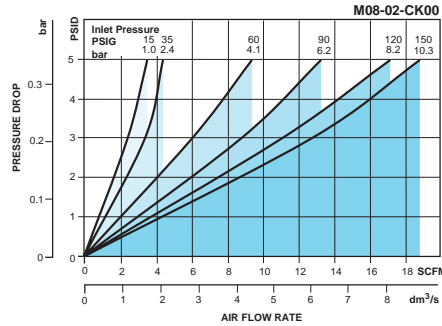
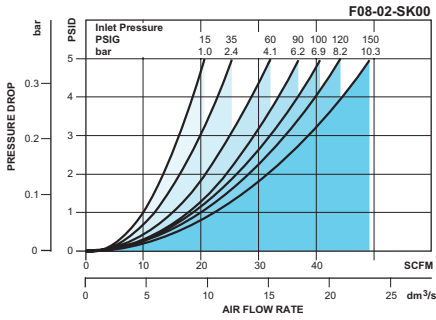

L08 / B08 / C08

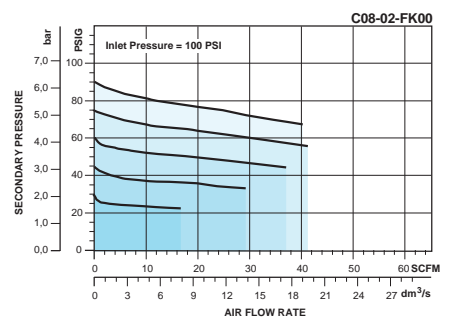
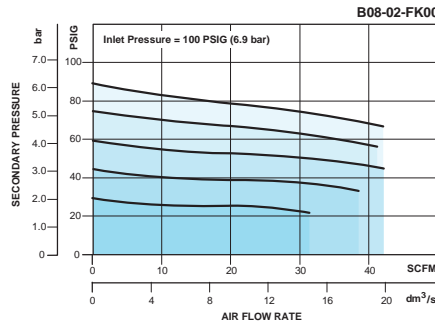
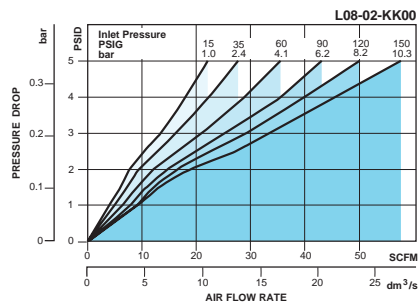

D08 / N08 / V08

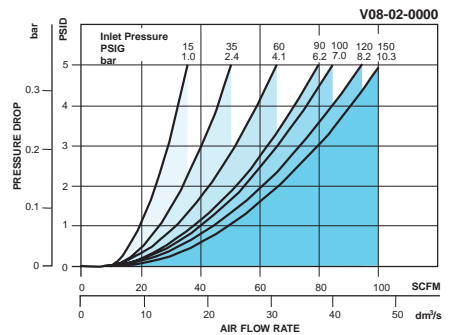
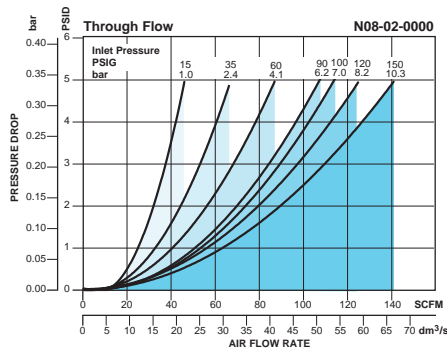
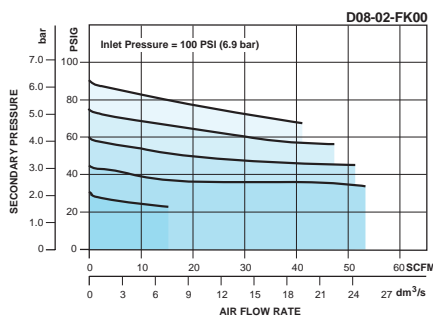

INTERMEDIATE MODULAR 18 AND STANDARD MODULAR 28 SERIES



F18



F28

Filters

The F18 intermediate and F28 standard particulate filters feature a 5 micron particulate element, quick disconnect plastic bowl with bowl guard and a manual pipe away type manual drain. Quick disconnect metal bowls and automatic drains are additional available options. Wilkerson F08 filters meet or exceed ISO class 3 for maximum particle size retention and removal.

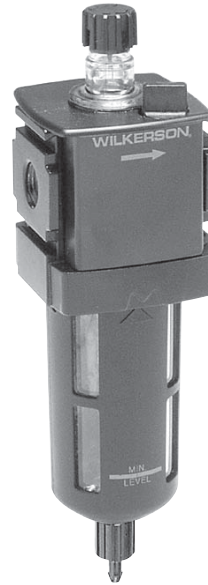

L18



L28

Lubricators

The L18 intermediate and L28 standard lubricators feature an integral clear sight dome and adjustment knob for quick setting of the lubrication rate. The L18 and L28 can also be replenished with oil while under pressure.



M18



M28

Coalescing Filters

The M18 intermediate and M28 standard coalescing filters provide high efficiency removal of water, oil aerosols and solid particulate contaminants down to .01 micron in size. All M18 and M28 Series coalescing filters come standard with mechanical differential indicators, quick disconnect plastic bowl with bowl guard and a manual pipe away type manual drain. Quick disconnect metal bowls and automatic drains are additional available options.

INTERMEDIATE MODULAR 18 AND STANDARD MODULAR 28 SERIES



R18



R28

Regulators

The R18 intermediate and R28 standard regulators feature a balanced valve for superior regulation characteristics. Two gauge ports, and a bottom plug for ease of maintenance serviceability are standard.



D18



D28

Filter / Regulator – Lubricator Combinations

The D18 intermediate and D28 standard modular combination models bring together all the superior features and functions of the 18 and 28 Series modular FRL product line into a compact, space-saving assembly. Joiner set with T-bracket is standard.



B18



B28

Filter / Regulators

The B18 intermediate and B28 standard integral filter / regulator air sets combine all the advanced features and functions of the standard filter and regulator into a single, space saving, high performance unit.

MODULAR 18 AND 28 SERIES

ACCESSORIES AND OPTIONS



Diverter Blocks

For increased design flexibility, the N18 diverter block is available in 1/2" threaded inlet / outlet ports. The N28 has 3/4" threaded inlet / outlet ports. The diverter block can be mounted anywhere in the FRL system. The unit comes with two 1/4", 3/8" or 1/2" threaded auxiliary ports. Also available with or without a check valve.



Safety Lockout Valves

The V18 and V28 safety lockout valves are manually operated slide-type 3-way valves. In the closed position, downstream air is exhausted to atmosphere. The valve slides can be locked in the closed position with a customer-supplied padlock. (Meets OSHA Reg 29 CFR Part 1910) Right to left flow models V19 and V29 are also available.



Gauges

Easy-to-read 1-1/2" faces with dual psi / bar scales make this an important accessory. Gauges come 0-30, 0-60, 0-160 and 0-300 psig ranges, 1/4" center back mounted. The 18 and 28 Series use the same gauges.



Metal Bowls & Automatic Drains

The 18 and 28 series both have an optional metal bowl with liquid level sight gauge and an automatic mechanical drain to meet your application needs.

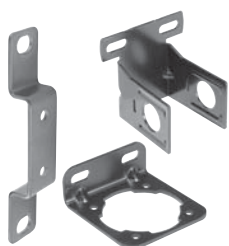

Modular T-Bracket, Type L-Bracket, & Type C-Bracket

A wide choice of unit mounting brackets and joiner assembly allow for easy unit installation, assembly, and mounting.

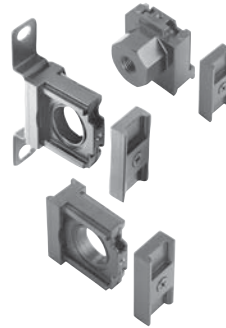

Modular Brackets & Joiner Assembly

A wide choice of unit mounting brackets and modular joiner hardware assemblies allow for easy unit installation, assembly and mounting. Wilkerson's modular joiner sets allow you to make easy, reliable and leak free combinations. **The 18 and 28 Series use the same joiner assembly.**



Modular Lockout Valves

These lockout valves have the ability to modularly mount into any standard 18 or 28 series assembly.

The V60 modular lockout valve is a 60mm ball valve style, the V73 modular lockout valve is a 73mm ball valve style.



Dump Valves

The Q19 series dump valves 3-way, 2-position function automatically dumps downstream pressure on the loss of pilot signal. It features both solenoid or air pilot options. Silencer included.



Emergency Stop Valves

The E18 and E28 emergency stop valves provide solenoid controlled operation to start the air system up smoothly, and the E-Stop function allows you to quickly exhaust, or "dump" the downstream air.



Proportional Pressure Regulators

The ER19 proportional pressure regulators provide all the advantages of a closed circuit regulated system. When a set value is defined via the input signal (e.g. 0-10 V), the pressure regulator sets the corresponding output pressure (e.g. 0-150 PSI/0-10 bar). At the same time the integrated pressure sensor measures the actual pressure at the unit's outlet (actual value).

INTERMEDIATE MODULAR 18 AND STANDARD MODULAR 28 SERIES

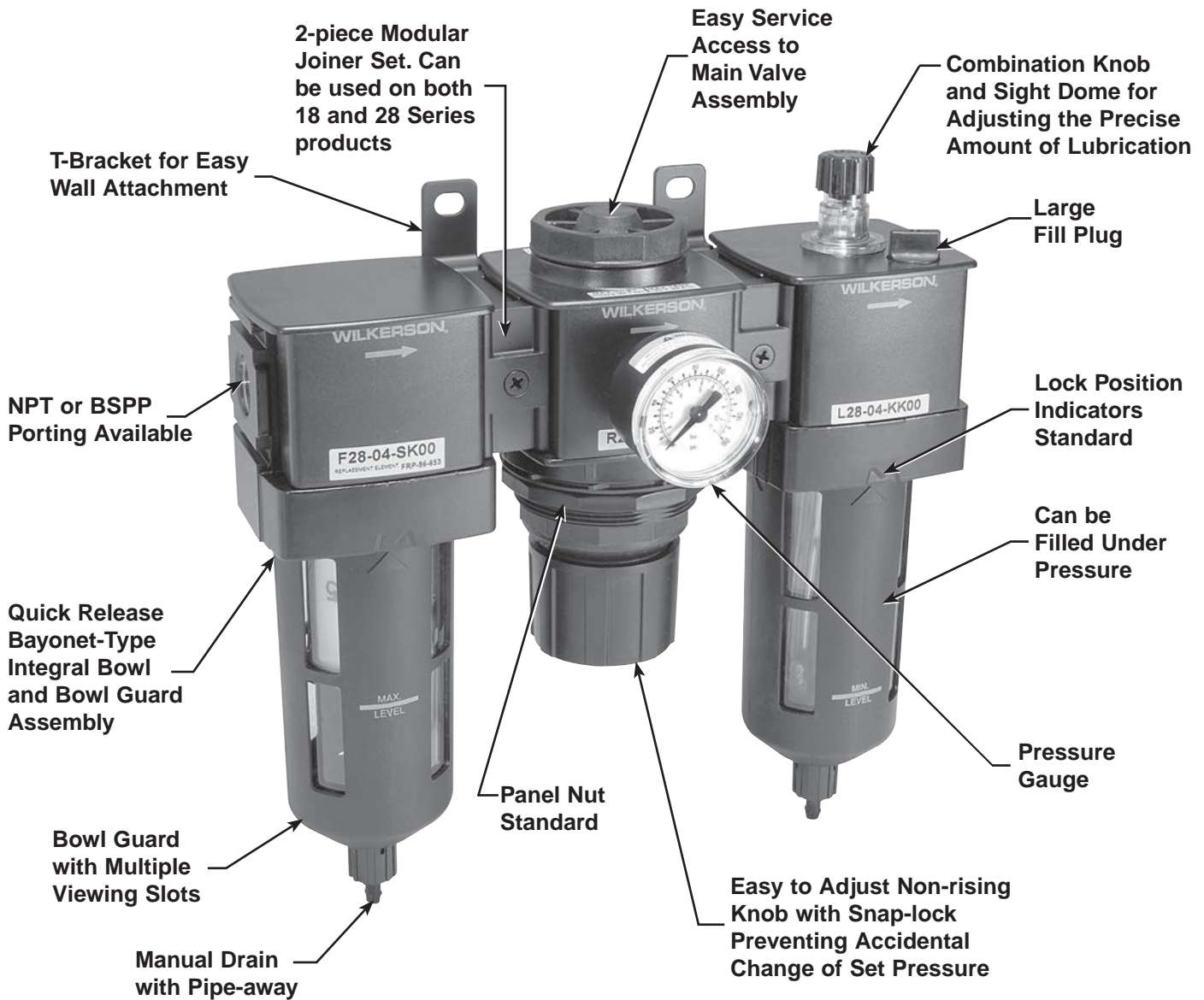

C28 Shown

Filter / Regulator / Lubricator Combination Units

The C18 and C28 modular FRL combination models integrate components of the advanced 18 and 28 product lines into a compact, lightweight, ready-to-mount assembly. The units come standard with pressure gauge

and are pre-assembled utilizing our modular T-bracket / joiner assembly for easy installation and mounting.

INTERMEDIATE MODULAR 18 SERIES

DIMENSIONAL DRAWINGS

Inches
(mm)

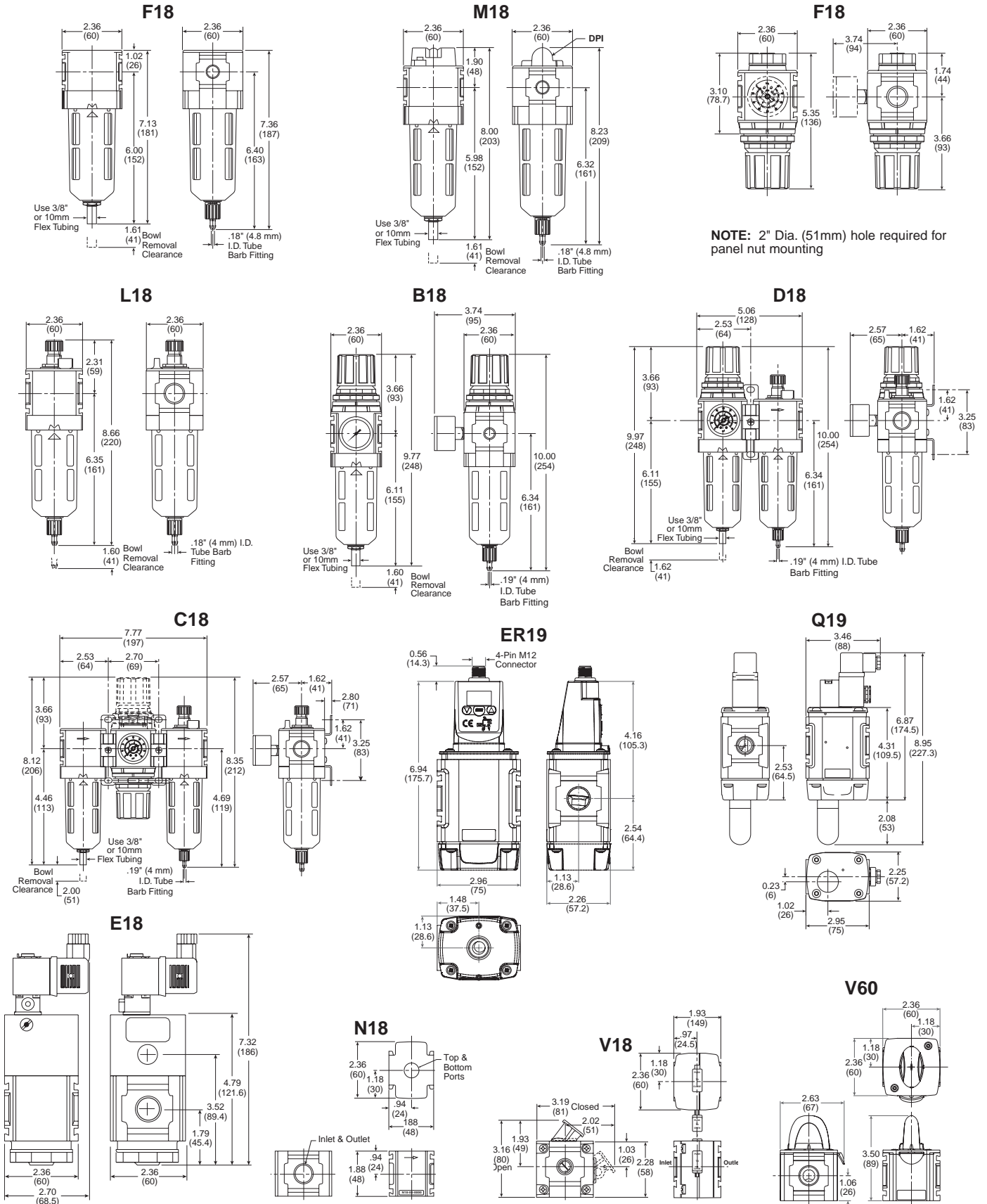

INTERMEDIATE MODULAR 18 SERIES

SPECIFICATIONS AND ORDERING DATA

Model No.	Description	Pipe Size NPT	Flow SCFM	Max. Pressure PSIG	Max. Temp °F	Bowl Capacity oz.	Height inches	Width inches	Depth inches	Weight lbs.
FILTERS* – PLASTIC BOWL WITH BOWL GUARD, 5 MICRON ELEMENT										
F18-02-SK00	Manual Drain	1/4	110	150	125°	1.72	7.40	2.36	2.36	1.08
F18-03-SK00	Manual Drain	3/8	120	150	125°	1.72	7.40	2.36	2.36	1.08
F18-04-SK00	Manual Drain	1/2	145	150	125°	1.72	7.40	2.36	2.36	1.08
F18-02-SG00	Automatic Drain	1/4	110	150	125°	1.72	7.40	2.36	2.36	1.08
F18-03-SG00	Automatic Drain	3/8	125	150	125°	1.72	7.40	2.36	2.36	1.08
F18-04-SG00	Automatic Drain	1/2	145	150	125°	1.72	7.40	2.36	2.36	1.08

COALESCING FILTERS* – PLASTIC BOWL WITH BOWL GUARD, MECHANICAL PRESSURE DIFFERENTIAL INDICATOR										
M18-02-CK00	Coalescing / Manual Drain	1/4	40	150	125°	1.72	8.20	2.36	2.36	1.1
M18-03-CK00	Coalescing / Manual Drain	3/8	44	150	125°	1.72	8.20	2.36	2.36	1.1
M18-04-CK00	Coalescing / Manual Drain	1/2	48	150	125°	1.72	8.20	2.36	2.36	1.1
M18-02-CG00	Coalescing / Automatic Drain	1/4	40	150	125°	1.72	8.20	2.36	2.36	1.1
M18-03-CG00	Coalescing / Automatic Drain	3/8	44	150	125°	1.72	8.20	2.36	2.36	1.1
M18-04-CG00	Coalescing / Automatic Drain	1/2	48	150	125°	1.72	8.20	2.36	2.36	1.1

REGULATORS* – 0-125 PSI ADJUSTMENT RANGE										
R18-02-F000	Relieving	1/4	82	300	150°	—	5.40	2.36	2.36	1.16
R18-02-FOG0	Relieving / Gauge	1/4	82	300	150°	—	5.40	2.36	2.36	1.16
R18-03-F000	Relieving	3/8	97	300	150°	—	5.40	2.36	2.36	1.16
R18-03-FOG0	Relieving / Gauge	3/8	97	300	150°	—	5.40	2.36	2.36	1.16
R18-04-F000	Relieving	1/2	97	300	150°	—	5.40	2.36	2.36	1.16
R18-04-FOG0	Relieving / Gauge	1/2	97	300	150°	—	5.40	2.36	2.36	1.16

LUBRICATORS* – PLASTIC BOWL WITH BOWL GUARD										
L18-02-KK00	Manual Drain	1/4	88	150	125°	4.09	8.35	2.36	2.36	1.2
L18-03-KK00	Manual Drain	3/8	90	150	125°	4.09	8.35	2.36	2.36	1.2
L18-04-KK00	Manual Drain	1/2	96	150	125°	4.09	8.35	2.36	2.36	1.2

For no drain use C in 7th position XXX-XX-XCXX

FILTER / REGULATORS* – PLASTIC BOWL WITH BOWL GUARD, 5 MICRON ELEMENT, 0-125 PSI ADJUSTMENT RANGE										
B18-02-FK00	Relieving	1/4	88	150	125°	1.72	10.0	2.36	2.36	1.48
B18-02-FKG0	Relieving / Gauge	1/4	88	150	125°	1.72	10.0	2.36	2.36	1.48
B18-02-FGG0	Relieving / Auto. Drain / Gauge	1/4	88	150	125°	1.72	10.0	2.36	2.36	1.48
B18-03-FK00	Relieving	3/8	117	150	125°	1.72	10.0	2.36	2.36	1.48
B18-03-FKG0	Relieving / Gauge	3/8	117	150	125°	1.72	10.0	2.36	2.36	1.48
B18-03-FGG0	Relieving / Auto. Drain / Gauge	3/8	117	150	125°	1.72	10.0	2.36	2.36	1.48
B18-04-FK00	Relieving	1/2	121	150	125°	1.72	10.0	2.36	2.36	1.48
B18-04-FKG0	Relieving / Gauge	1/2	121	150	125°	1.72	10.0	2.36	2.36	1.48
B18-04-FGG0	Relieving / Auto. Drain / Gauge	1/2	121	150	125°	1.72	10.0	2.36	2.36	1.48

Metal bowl with sight gauge, manual drain use L in 7th position XXX-XX-XLXX

Metal bowl with sight gauge, auto drain use H in 7th position XXX-XX-XHXX

*Unit models are available in BSPP by placing a "C" in the 4th position of the unit model number.

INTERMEDIATE MODULAR 18 SERIES

SPECIFICATIONS AND ORDERING DATA

Model No.	Description	Pipe Size NPT	Max. Flow SCFM	Max. Pressure PSIG	Max. Temp °F	Height inches	Width inches	Depth inches	Weight lbs.
3-UNIT COMBINATIONS* – PLASTIC BOWL WITH BOWL GUARD, 5 MICRON ELEMENT, 0-125 PSI ADJUSTMENT RANGE, PRESSURE GAUGE									
C18-02-FKG0	Filter + Regulator + Lubricator / Manual Drain	1/4	102	150	125°	8.35	7.77	4.18	4.04
C18-03-FKG0	Filter + Regulator + Lubricator / Manual Drain	3/8	102	150	125°	8.35	7.77	4.18	4.04
C18-04-FKG0	Filter + Regulator + Lubricator / Manual Drain	1/2	102	150	125°	8.35	7.77	4.18	4.04
C18-02-FGG0	Filter + Regulator + Lubricator / Automatic Drain	1/4	102	150	125°	8.35	7.77	4.18	4.04
C18-03-FGG0	Filter + Regulator + Lubricator / Automatic Drain	3/8	102	150	125°	8.35	7.77	4.18	4.04
C18-04-FGG0	Filter + Regulator + Lubricator / Automatic Drain	1/2	102	150	125°	8.35	7.77	4.18	4.04

2-UNIT COMBINATIONS* – PLASTIC BOWL WITH BOWL GUARD, 5 MICRON ELEMENT, 0-125 PSI ADJUSTMENT RANGE, PRESSURE GAUGE									
D18-02-FKG0	Filter / Regulator + Lubricator / Manual Drain	1/4	67	150	125°	10.0	5.06	4.18	2.98
D18-03-FKG0	Filter / Regulator + Lubricator / Manual Drain	3/8	96	150	125°	10.0	5.06	4.18	2.98
D18-04-FKG0	Filter / Regulator + Lubricator / Manual Drain	1/2	96	150	125°	10.0	5.06	4.18	2.98
D18-02-FGG0	Filter / Regulator + Lubricator / Automatic Drain	1/4	67	150	125°	10.0	5.06	4.18	2.98
D18-03-FGG0	Filter / Regulator + Lubricator / Automatic Drain	3/8	96	150	125°	10.0	5.06	4.18	2.98
D18-04-FGG0	Filter / Regulator + Lubricator / Automatic Drain	1/2	96	150	125°	10.0	5.06	4.18	2.98

OPTIONS, ACCESSORIES AND KITS									
K4515N14300	Gauge 0-300 PSIG / 1.5" Dial Face	—	—	—	—	—	1.64	1.09	—
K4515N14160	Gauge 0-160 PSIG / 1.5" Dial Face	—	—	—	—	—	1.64	1.09	—
K4515N14060	Gauge 0-60 PSIG / 1.5" Dial Face	—	—	—	—	—	1.64	1.09	—
K4515N14030	Gauge 0-30 PSIG / 1.5" Dial Face	—	—	—	—	—	1.64	1.09	—
GPA-96-610	End Port Block	1/4	—	—	—	—	—	1.59	—
GPA-96-611	End Port Block	3/8	—	—	—	—	—	1.59	—
GPA-96-612	End Port Block	1/2	—	—	—	—	—	1.59	—
GPA-96-613	End Port Block	3/4	—	—	—	—	—	1.59	—
GPA-96-601	Modular Joiner Set	—	—	—	—	—	.35	—	—
GPA-96-603	T-Bracket / Modular Joiner Set	—	—	—	—	—	.35	—	—
GPA-96-606	L-Type Bracket	—	—	—	—	2.74	2.74	2.0	—
GPA-96-604	L-Type Bracket	—	—	—	—	2.84	2.74	1.0	—
GPA-96-602	T-Type Bracket	—	—	—	—	3.75	.76	—	—
RRP-96-673	Panel Mount Nut (Aluminum)	—	—	—	—	—	—	—	—
RRP-96-675	Panel Mount Nut (Plastic)	—	—	—	—	—	—	—	—
GRP-95-973	Automatic Float Drain Kit	—	—	—	—	—	—	—	—
GRP-96-001	Manual Override Drain	—	—	—	—	—	—	—	—
FRP-96-639	5 Micron Replacement Element Kit - For use with F18 / B18	—	—	—	—	—	—	—	—
MSP-96-647	.5 Micron Element Kit - For use with M18	—	—	—	—	—	—	—	—
MTP-96-646	.01 Micron Element Kit - For use with M18	—	—	—	—	—	—	—	—
MXP-96-650	Activated Carbon Element Kit - For use with M18	—	—	—	—	—	—	—	—
GRP-96-634	Plastic Bowl / Bowl Guard / Manual Drain	—	—	—	—	—	—	—	—
GRP-96-636	Metal Bowl / Sight Gauge / Manual Drain	—	—	—	—	—	—	—	—

OTHER PRODUCTS									
V18-02-0000**	Safety Lockout Valve	1/4	141	150	150°	3.16	2.36	3.19	.74
V18-03-0000	Safety Lockout Valve	3/8	216	150	150°	3.16	2.36	3.19	.74
V18-04-0000	Safety Lockout Valve	1/2	272	150	150°	3.16	2.36	3.19	.74
V60-04-B000	Modular Ball Valve	3/8	190	246	150°	3.50	2.36	2.36	.47
V60-06-B000	Modular Ball Valve	1/2	258	246	150°	3.50	2.36	2.36	.47
E18-02-EC00	Soft Start / Quick Dump Valve	1/4	95	150	150°	7.32	60	60	2.23
E18-03-EC00	Soft Start / Quick Dump Valve	3/8	101	150	150°	7.32	60	60	2.23
E18-04-EC00	Soft Start / Quick Dump Valve	1/2	113	150	150°	7.32	60	60	2.23
N18-04-0000	Diverter Block	1/2	400	300	150°	1.88	2.36	1.88	.26
N18-04-C000	Diverter Block with Check Valve	1/2	400	300	150°	1.88	2.36	1.88	.26
Q19-04-EC00	Dump Valve - 24VDC, 30mm Coil	1/2	108	150	122°	8.95	3.46	2.25	2.0
ER19-04-0000	Electronic Proportional Regulator	1/2	120	152	122°	7.50	2.96	57.2	1.42

*Unit models are available in BSPP by placing a "C" in the 4th position of the unit model number.

**V18 flow is left to right. For right to left flow, order model V19.

INTERMEDIATE MODULAR 18 SERIES

FLOW CHARTS

Note: Regulator flow data based on inlet pressure = 100 PSIG, all others = 150 PSIG

F18 / M18 / R18

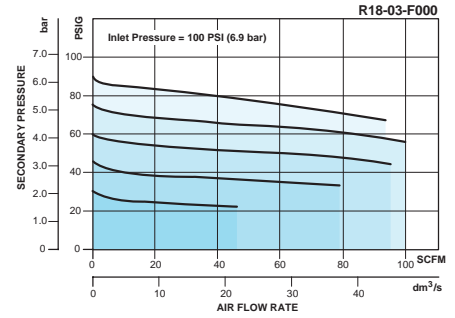
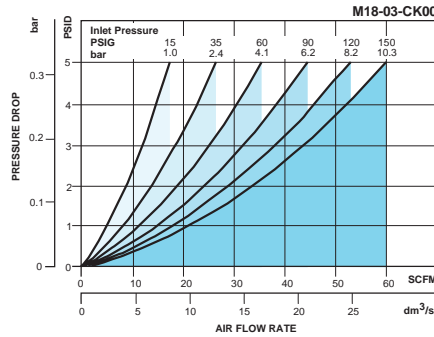
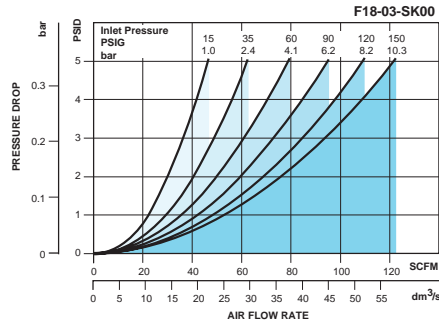

L18 / B18 / C18

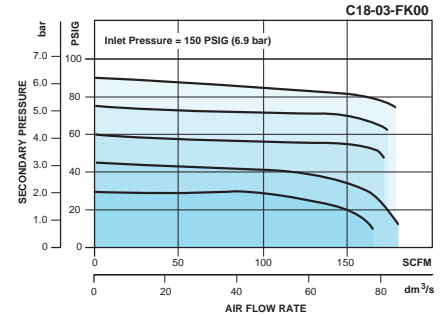
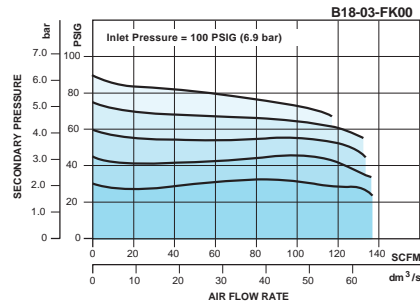
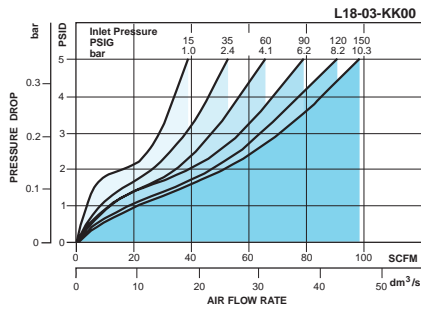

D18 / N18 / V18

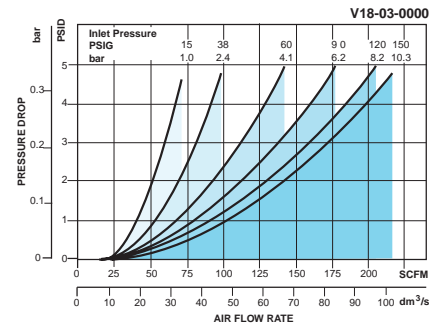
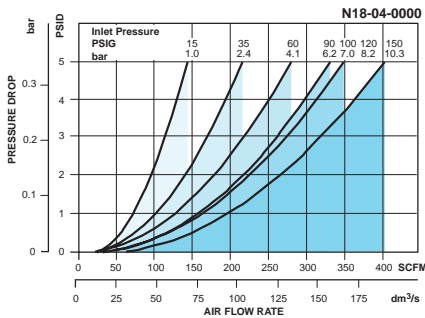
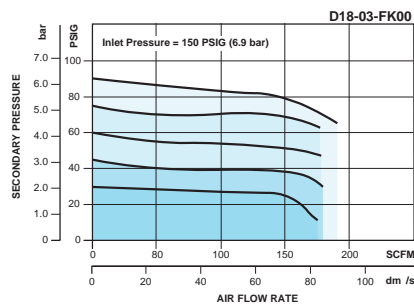

STANDARD MODULAR 28 SERIES

DIMENSIONAL DRAWINGS

Inches
(mm)

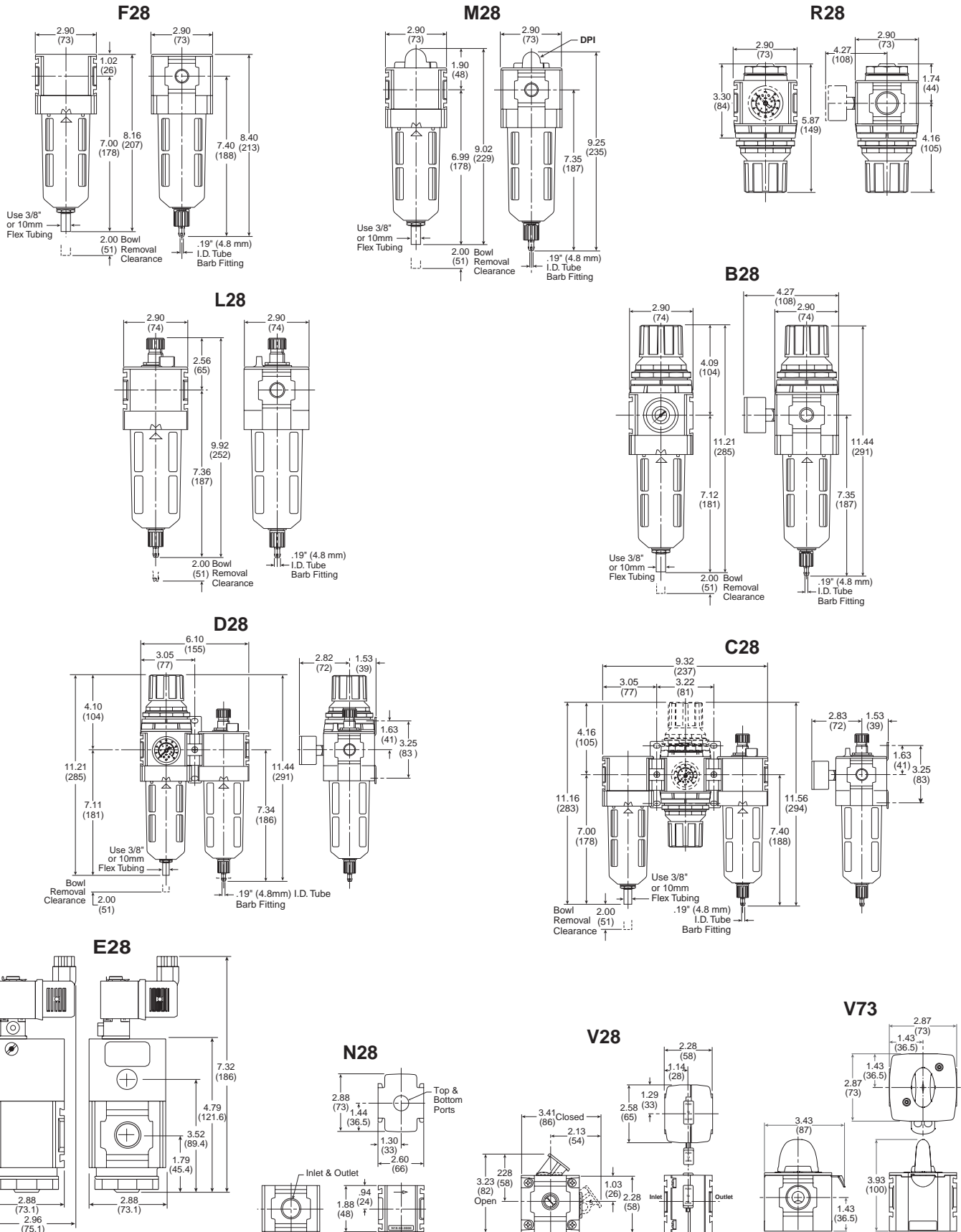

STANDARD MODULAR 28 SERIES

SPECIFICATIONS AND ORDERING DATA

Model No.	Description	Pipe Size NPT	Max. Flow SCFM	Max. Pressure PSIG	Max. Temp °F	Bowl Capacity oz.	Height inches	Width inches	Depth inches	Weight lbs.
FILTERS* – PLASTIC BOWL WITH BOWL GUARD, 5 MICRON ELEMENT										
F28-03-SK00	Manual Drain	3/8	144	150	125°	2.87	8.40	2.90	2.90	1.70
F28-04-SK00	Manual Drain	1/2	160	150	125°	2.87	8.40	2.90	2.90	1.70
F28-06-SK00	Manual Drain	3/4	165	150	125°	2.87	8.40	2.90	2.90	1.70
F28-03-SG00	Automatic Drain	3/8	144	150	125°	2.87	8.40	2.90	2.90	1.70
F28-04-SG00	Automatic Drain	1/2	160	150	125°	2.87	8.40	2.90	2.90	1.70
F28-06-SG00	Automatic Drain	3/4	165	150	125°	2.87	8.40	2.90	2.90	1.70

COALESCING FILTERS* – PLASTIC BOWL WITH BOWL GUARD, MECHANICAL PRESSURE DIFFERENTIAL INDICATOR										
M28-03-CK00	Coalescing / Manual Drain	3/8	82	150	125°	2.89	9.30	2.90	2.90	1.70
M28-04-CK00	Coalescing / Manual Drain	1/2	90	150	125°	2.89	9.30	2.90	2.90	1.70
M28-06-CK00	Coalescing / Manual Drain	3/4	98	150	125°	2.89	9.30	2.90	2.90	1.70
M28-03-CG00	Coalescing / Automatic Drain	3/8	82	150	125°	2.89	9.30	2.90	2.90	1.70
M28-04-CG00	Coalescing / Automatic Drain	1/2	90	150	125°	2.89	9.30	2.90	2.90	1.70
M28-06-CG00	Coalescing / Automatic Drain	3/4	98	150	125°	2.89	9.30	2.90	2.90	1.70

REGULATORS* – 0-125 PSI ADJUSTMENT										
R28-03-F000	Relieving	3/8	162	300	150°	—	5.90	2.90	2.90	1.70
R28-03-F0G0	Relieving / Gauge	3/8	162	300	150°	—	5.90	2.90	2.90	1.70
R28-04-F000	Relieving	1/2	170	300	150°	—	5.90	2.90	2.90	1.70
R28-04-F0G0	Relieving / Gauge	1/2	170	300	150°	—	5.90	2.90	2.90	1.70
R28-06-F000	Relieving	3/4	176	300	150°	—	5.90	2.90	2.90	1.70
R28-06-F0G0	Relieving / Gauge	3/4	176	300	150°	—	5.90	2.90	2.90	1.70

LUBRICATORS* – PLASTIC BOWL WITH BOWL GUARD										
L28-03-KK00	Manual Drain	3/8	176	150	125°	6.11	9.36	2.90	2.90	1.9
L28-04-KK00	Manual Drain	1/2	184	150	125°	6.11	9.36	2.90	2.90	1.9
L28-06-KK00	Manual Drain	3/4	200	150	125°	6.11	9.36	2.90	2.90	1.9

For no drain use C in 7th position XXX-XX-**XCXX**

FILTER / REGULATORS* – PLASTIC BOWL WITH BOWL GUARD										
B28-03-FK00	Relieving	3/8	140	150	125°	2.87	11.44	2.90	2.90	2.45
B28-03-FKG0	Relieving / Gauge	3/8	140	150	125°	2.87	11.44	2.90	2.90	2.45
B28-03-FGG0	Relieving / Automatic Drain / Gauge	3/8	140	150	125°	2.87	11.44	2.90	2.90	2.45
B28-04-FK00	Relieving	1/2	165	150	125°	2.87	11.44	2.90	2.90	2.45
B28-04-FKG0	Relieving / Gauge	1/2	165	150	125°	2.87	11.44	2.90	2.90	2.45
B28-04-FGG0	Relieving / Automatic Drain / Gauge	1/2	165	150	125°	2.87	11.44	2.90	2.90	2.45
B28-06-FK00	Relieving	3/4	175	150	125°	2.87	11.44	2.90	2.90	2.45
B28-06-FKG0	Relieving / Gauge	3/4	175	150	125°	2.87	11.44	2.90	2.90	2.45
B28-06-FGG0	Relieving / Automatic Drain / Gauge	3/4	175	150	125°	2.87	11.44	2.90	2.90	2.45

For metal bowl manual drain use L in 7th position XXX-XX-**XLXX**

For metal bowl automatic drain use H in 7th position XXX-XX-**XHXX**

*Unit models are available in BSPP by placing a "C" in the 4th position of the unit model number.

STANDARD MODULAR 28 SERIES

SPECIFICATIONS AND ORDERING DATA

Model No.	Description	Pipe Size NPT	Max. Flow SCFM	Max. Pressure PSIG	Max. Temp °F	Height inches	Width inches	Depth inches	Weight lbs.
3-UNIT COMBINATIONS* – PLASTIC BOWL WITH BOWL GUARD, 5 MICRON ELEMENT, 0-125 PSI ADJUSTMENT, PRESSURE GAUGE									
C28-03-FKG0	Filter + Regulator + Lubricator / Manual Drain	3/8	123	150	125°	9.36	9.32	4.35	5.90
C28-04-FKG0	Filter + Regulator + Lubricator / Manual Drain	1/2	134	150	125°	9.36	9.32	4.35	5.90
C28-06-FKG0	Filter + Regulator + Lubricator / Manual Drain	3/4	143	150	125°	9.36	9.32	4.35	5.90
C28-03-FGG0	Filter + Regulator + Lubricator / Automatic Drain	3/8	123	150	125°	9.36	9.32	4.35	5.90
C28-04-FGG0	Filter + Regulator + Lubricator / Automatic Drain	1/2	134	150	125°	9.36	9.32	4.35	5.90
C28-06-FGG0	Filter + Regulator + Lubricator / Automatic Drain	3/4	143	150	125°	9.36	9.32	4.35	5.90

2-UNIT COMBINATIONS* – PLASTIC BOWL WITH BOWL GUARD, 5 MICRON ELEMENT, 0-125 PSI ADJUSTMENT, PRESSURE GAUGE									
D28-03-FKG0	Filter / Regulator + Lubricator / Manual Drain	3/8	105	150	125°	11.44	6.10	4.35	4.65
D28-04-FKG0	Filter / Regulator + Lubricator / Manual Drain	1/2	110	150	125°	11.44	6.10	4.35	4.65
D28-06-FKG0	Filter / Regulator + Lubricator / Manual Drain	3/4	130	150	125°	11.44	6.10	4.35	4.65
D28-03-FGG0	Filter / Regulator + Lubricator / Automatic Drain	3/8	105	150	125°	11.44	6.10	4.35	4.65
D28-04-FGG0	Filter / Regulator + Lubricator / Automatic Drain	1/2	110	150	125°	11.44	6.10	4.35	4.65
D28-06-FGG0	Filter / Regulator + Lubricator / Automatic Drain	3/4	130	150	125°	11.44	6.10	4.35	4.65

OPTIONS, ACCESSORIES AND KITS									
K4515N14300	Gauge 0-300 PSIG / 1.5" Dial Face	—	—	—	—	—	1.64	1.09	—
K4515N14160	Gauge 0-160 PSIG / 1.5" Dial Face	—	—	—	—	—	1.64	1.09	—
K4515N14060	Gauge 0-60 PSIG / 1.5" Dial Face	—	—	—	—	—	1.64	1.09	—
K4515N14030	Gauge 0-30 PSIG / 1.5" Dial Face	—	—	—	—	—	1.64	1.09	—
GPA-96-610	End Port Block	1/4	—	—	—	—	—	1.59	—
GPA-96-611	End Port Block	3/8	—	—	—	—	—	1.59	—
GPA-96-612	End Port Block	1/2	—	—	—	—	—	1.59	—
GPA-96-613	End Port Block	3/4	—	—	—	—	—	1.59	—
GPA-96-601	Modular Joiner Set	—	—	—	—	—	.35	—	—
GPA-96-603	T-Bracket / Modular Joiner Set	—	—	—	—	—	.35	—	—
GPA-96-607	L-Type Bracket	—	—	—	—	2.74	2.74	2.0	—
GPA-96-605	C-Type Bracket	—	—	—	—	2.84	2.74	1.0	—
GPA-96-602	T-Type Bracket	—	—	—	—	3.75	.76	—	—
RRP-96-674	Panel Mount Nut (Aluminum)	—	—	—	—	—	—	—	—
RRP-96-676	Panel Mount Nut (Plastic)	—	—	—	—	—	—	—	—
GRP-95-973	Automatic Float Drain Kit	—	—	—	—	—	—	—	—
GRP-96-001	Manual Override Drain	—	—	—	—	—	—	—	—
FRP-96-653	5 Micron Replacement Element Kit - For use with F18 / B18	—	—	—	—	—	—	—	—
MSP-96-649	.5 Micron Element Kit - For use with M28	—	—	—	—	—	—	—	—
MTP-96-648	.01 Micron Element Kit - For use with M28	—	—	—	—	—	—	—	—
MXP-96-651	Activated Carbon Element Kit - For use with M28	—	—	—	—	—	—	—	—
GRP-96-642	Plastic Bowl / Bowl Guard / Manual Drain	—	—	—	—	—	—	—	—
GRP-96-644	Metal Bowl / Sight Gauge / Manual Drain	—	—	—	—	—	—	—	—

OTHER PRODUCTS									
V28-03-0000**	Safety Lockout Valve	3/8	117	150	150°	3.23	2.36	3.41	.90
V28-04-0000	Safety Lockout Valve	1/2	216	150	150°	3.23	2.36	3.41	.90
V28-06-0000	Safety Lockout Valve	3/4	168	150	150°	3.23	2.36	3.41	.90
V73-04-B000	Modular Ball Valve	1/2	561	246	150°	2.87	1.65	1.57	.80
V73-06-B000	Modular Ball Valve	3/4	678	246	150°	2.87	1.65	1.57	.80
E28-02-EC00	Soft Start / Quick Dump Valve	3/8	196	150	150°	7.32	73	73	2.50
E28-03-EC00	Soft Start / Quick Dump Valve	1/2	210	150	150°	7.32	73	73	2.50
E28-04-EC00	Soft Start / Quick Dump Valve	3/4	230	150	150°	7.32	73	73	2.50
N28-06-0000	Diverter Block	3/4	647	300	150°	1.88	2.88	2.60	.94
N28-06-C000	Diverter Block with Check Valve	3/4	647	300	150°	1.88	2.88	2.87	.94

*Unit models are available in BSPP by placing a "C" in the 4th position of the unit model number.

**V28 flow is left to right. For right to left flow, order model V29.

STANDARD MODULAR 28 SERIES

FLOW CHARTS

Note: Regulator flow data based on inlet pressure = 100 PSIG, all others = 150 PSIG

F28 / M28 / R28

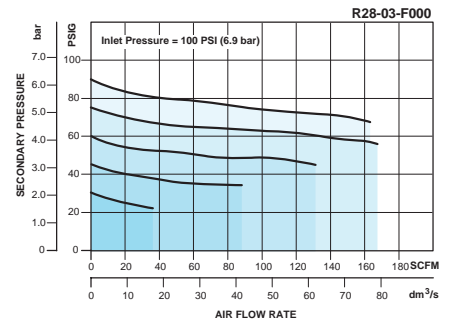
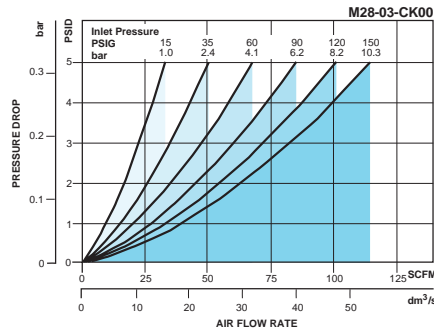
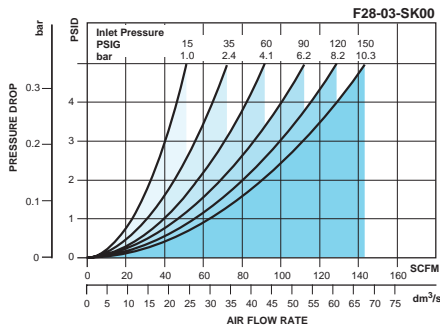

L28 / B28 / C28

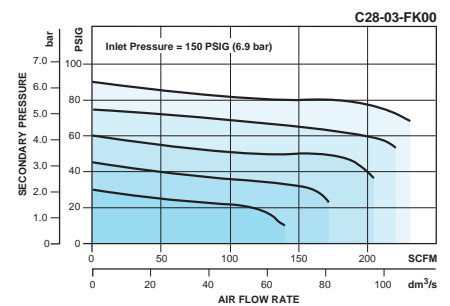
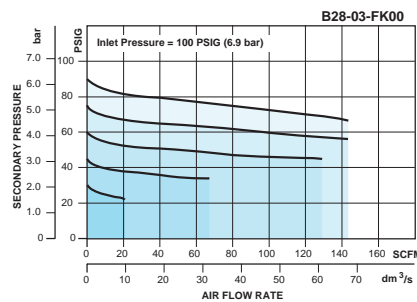
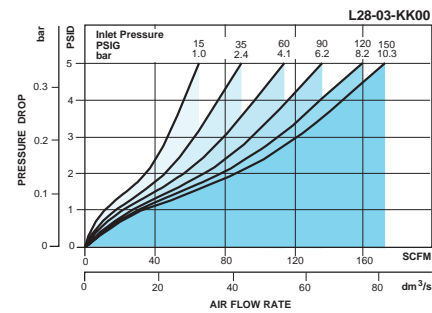

D28 / N28 / V28

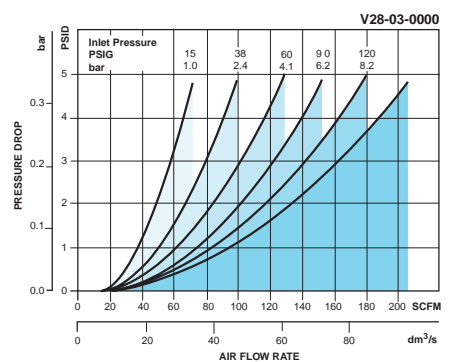
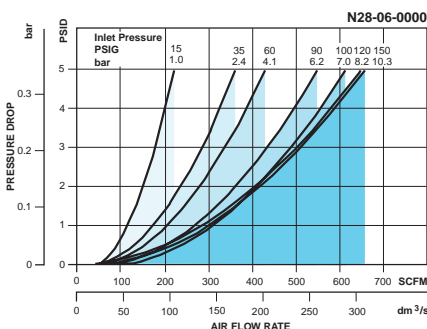
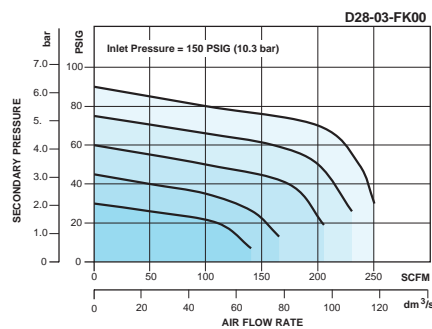

THE TOTAL SYSTEMS APPROACH TO AIR PREPARATION

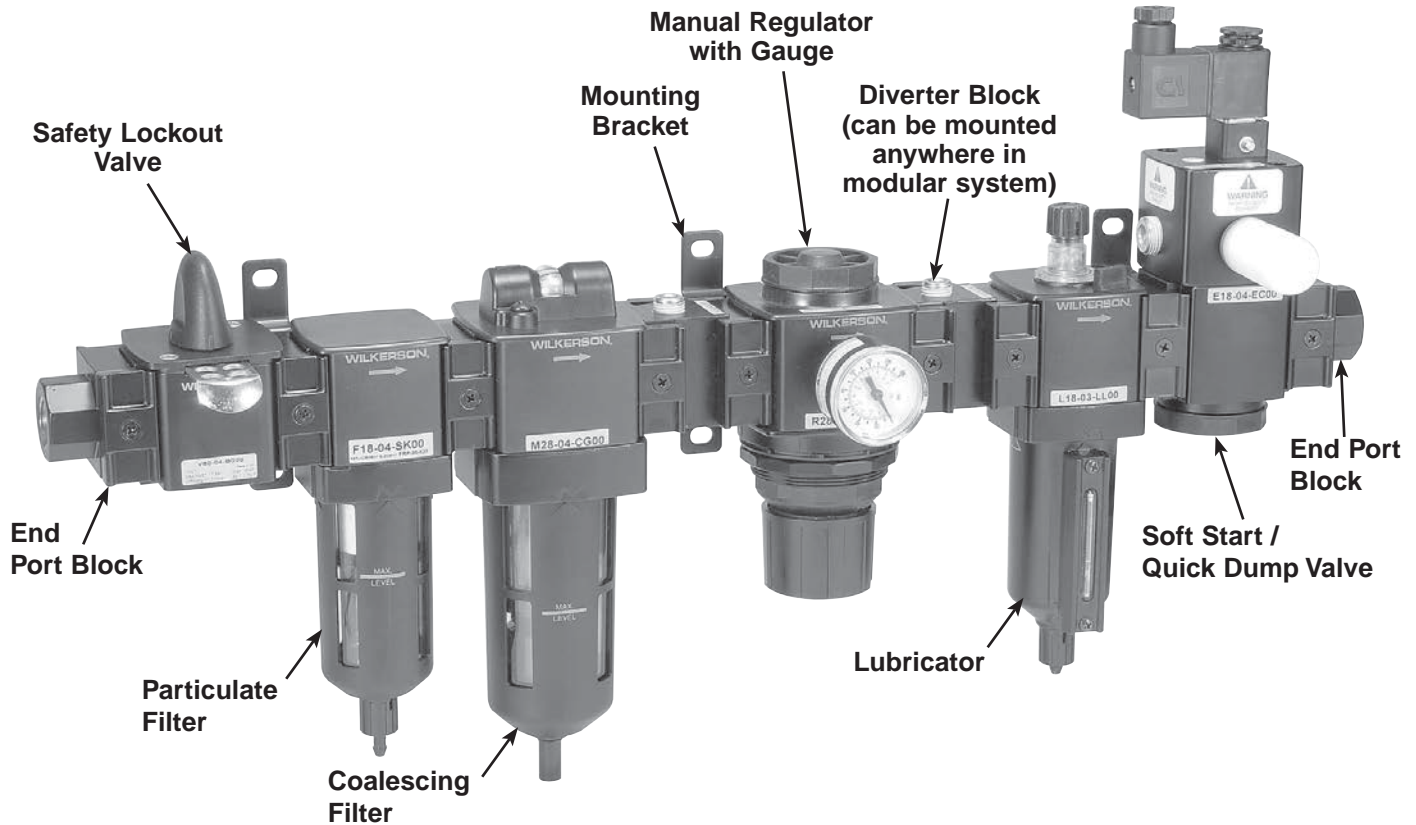

WILKERSON has been the industry leader in manufacturing innovative compressed air preparation products for 50 years. As pneumatic components and systems have become more complex and sophisticated, the need for better air preparation has also grown. While Wilkerson individual components can be used by themselves with good results, the key to a successful pneumatic system is to take the systems approach to designing performance and efficiency into the air system.

Wilkerson's 18 and 28 Modular Series products provide the system designer with many tools and options to successfully design an air preparation system that provides:

- High flows
- Minimum pressure drops
- Ease of installation
- Simplified maintenance and spare parts inventory
- Efficient space utilization
- Design flexibility with accessories and options
- Products to help comply with Industrial safety regulations
- Innovative products for remote process control and monitoring

The Wilkerson 18 and 28 Series Modular units use the same joiner set, which allows you to mix and match the two families. A good example might be using an F28 filter with an R18 regulator. The use of the larger filter provides long element

life with low pressure drops (efficiency), while the regulator provides cost savings.

The trend in industry is to automate process control and monitoring. Wilkerson's 18 and 28 Series specialty products can help to automate the control of the pneumatic system:

The E18 and E28 Emergency Stop Valves provide solenoid controlled operation to start the air system up smoothly, and the E-Stop function allows you to quickly exhaust, or "dump" the downstream air.

The ER1 and ER2 Electronic Regulators allow both remote control of the regulator and monitoring of regulated downstream pressure. In addition the process control can become "closed-loop", with a PC or PLC controlling the process and automatically making adjustments to the air system.

Pressure switches can be used anywhere in the system, and can either monitor system pressure or can control another function. There are two sets of contacts, one normally-open and one normally-closed.

Designing efficiency into the system is easy to do, and over the life of the system, can often save hundreds or even thousands of dollars in energy costs, maintenance costs, and production costs.

When you need Innovative Compressed Air Products for your pneumatic system, look to the leader—WILKERSON!

MATERIALS OF CONSTRUCTION

Filter	F08	F18	F28
Body	Zinc	Zinc	Zinc
Body Cap	ABS	ABS	ABS
Bowl - Metal	Zinc	Aluminum	Aluminum
Bowl - Plastic	Polycarbonate	Polycarbonate	Polycarbonate
Bowl Guard	Nylon	Nylon	Nylon
Baffle / Element Retainer	Acetal	Acetal	Acetal
Element - 5 Micron	Sintered Polyethylene	Sintered Polyethylene	Sintered Polyethylene
Seals - Plastic Bowl	Nitrile	Nitrile	Nitrile
Seals - Metal Bowl	Nitrile	Nitrile	Nitrile
Sight Gauge	N/A	Nylon	Nylon

Coalescing Filter	M08	M18	M28
Body	Zinc	Zinc	Zinc
Body Cap	ABS	ABS	ABS
Bowl - Metal	Zinc	Aluminum	Aluminum
Bowl - Plastic	Polycarbonate	Polycarbonate	Polycarbonate
Bowl Guard	Nylon	Nylon	Nylon
Element - Type "C" And "B"	Borosilicate Cloth	Borosilicate Cloth	Borosilicate Cloth
Element - Type "D"	Activated Carbon	Activated Carbon	Activated Carbon
Seals - Plastic Bowl	Nitrile	Nitrile	Nitrile
Seals - Metal Bowl	Nitrile	Nitrile	Nitrile
Sight Gauge	N/A	Nylon	Nylon

Regulator	R08 / R09	R18 / R19	R28
Adjustment Knob	Acetal	Acetal	Acetal
Body	Zinc	Zinc	Zinc
Body Cap	ABS	ABS	ABS
Bonnet	PBT	33% Glass Filled Nylon	33% Glass Filled Nylon
Bottom Plug	33% Glass Filled Nylon	33% Glass Filled Nylon	33% Glass Filled Nylon
Diaphragm Assembly	Brass / Nitrile	Nitrile / Zinc	Nitrile / Zinc
Panel Nut	Acetal	Acetal	Acetal
Seals	Nitrile	Nitrile	Nitrile
Spring - Main Regulating	Steel	Steel	Steel
Springs - Valve	Steel	Stainless Steel	Stainless Steel
Valve Assembly	Brass / Nitrile	Brass / Nitrile	Brass / Nitrile / Acetal

Filter / Regulator	B08	B18	B28
Adjustment Knob	Acetal	Acetal	Acetal
Body	Zinc	Zinc	Zinc
Body Cap	ABS	ABS	ABS
Bonnet	PBT	33% Glass Filled Nylon	33% Glass Filled Nylon
Bowl - Metal	Zinc	Aluminum	Aluminum
Bowl - Plastic	Polycarbonate	Polycarbonate	Polycarbonate
Bowl Guard	Nylon	Nylon	Nylon
Diaphragm Assembly	Brass / Nitrile	Nitrile / Zinc	Nitrile / Zinc
Element - 5 Micron	Sintered Polyethylene	Sintered Polyethylene	Sintered Polyethylene
Panel Nut	Acetal	Acetal	Acetal
Seals - Plastic Bowl	Nitrile	Nitrile	Nitrile
Seals - Metal Bowl	Nitrile	Nitrile	Nitrile
Sight Gauge	N/A	Nylon	Nylon
Spring - Main Regulating	Steel	Steel	Steel
Springs - Valve	Steel	Stainless Steel	Stainless Steel
Valve Assembly	Brass / Nitrile	Brass / Nitrile	Brass / Nitrile / Acetal

Lubricator	L08	L18	L28
Body	Zinc	Zinc	Zinc
Body Cap	ABS	ABS	ABS
Bowl - Metal	Zinc	Aluminum	Aluminum
Bowl - Plastic	Polycarbonate	Polycarbonate	Polycarbonate
Seals - Plastic Bowl	Nitrile	Nitrile	Nitrile
Seals - Metal Bowl	Nitrile	Nitrile	Nitrile
Sight Gauge	N/A	Nylon	Nylon
Adjustment Dome	Polycarbonate	Polycarbonate	Polycarbonate
Pick Up Filter	Sintered Bronze	Sintered Bronze	Sintered Bronze

Safety Guide For Selecting And Using Pneumatic Division Products And Related Accessories



WARNING:

FAILURE OR IMPROPER SELECTION OR IMPROPER USE OF PNEUMATIC DIVISION PRODUCTS, ASSEMBLIES OR RELATED ITEMS ("PRODUCTS") CAN CAUSE DEATH, PERSONAL INJURY, AND PROPERTY DAMAGE. POSSIBLE CONSEQUENCES OF FAILURE OR IMPROPER SELECTION OR IMPROPER USE OF THESE PRODUCTS INCLUDE BUT ARE NOT LIMITED TO:

- Unintended or mistimed cycling or motion of machine members or failure to cycle
- Work pieces or component parts being thrown off at high speeds.
- Failure of a device to function properly for example, failure to clamp or unclamp an associated item or device.
- Explosion
- Suddenly moving or falling objects.
- Release of toxic or otherwise injurious liquids or gasses.

Before selecting or using any of these Products, it is important that you read and follow the instructions below.

1. GENERAL INSTRUCTIONS

- 1.1. Scope:** This safety guide is designed to cover general guidelines on the installation, use, and maintenance of Pneumatic Division Valves, FRLs (Filters pressure Regulators and Lubricators), Vacuum products and related accessory components.
- 1.2. Fail-Safe:** Valves, FRLs, Vacuum products and their related components can and do fail without warning for many reasons. Design all systems and equipment in a fail-safe mode, so that failure of associated valves, FRLs or Vacuum products will not endanger persons or property.
- 1.3. Relevant International Standards:** For a good guide to the application of a broad spectrum of pneumatic fluid power devices see: ISO 4414:1998, Pneumatic Fluid Power – General Rules Relating to Systems. See www.iso.org for ordering information.
- 1.4. Distribution:** Provide a copy of this safety guide to each person that is responsible for selection, installation, or use of Valves, FRLs or Vacuum products. Do not select, or use Wilkerson valves, FRLs or vacuum products without thoroughly reading and understanding this safety guide as well as the specific Wilkerson publications for the products considered or selected.
- 1.5. User Responsibility:** Due to the wide variety of operating conditions and applications for valves, FRLs, and vacuum products Wilkerson and its distributors do not represent or warrant that any particular valve, FRL or vacuum product is suitable for any specific end use system. This safety guide does not analyze all technical parameters that must be considered in selecting a product. The user, through its own analysis and testing, is solely responsible for:
 - Making the final selection of the appropriate valve, FRL, Vacuum component, or accessory.
 - Assuring that all user's performance, endurance, maintenance, safety, and warning requirements are met and that the application presents no health or safety hazards.
 - Complying with all existing warning labels and / or providing all appropriate health and safety warnings on the equipment on which the valves, FRLs or Vacuum products are used; and,
 - Assuring compliance with all applicable government and industry standards.
- 1.6. Safety Devices:** Safety devices should not be removed, or defeated.
- 1.7. Warning Labels:** Warning labels should not be removed, painted over or otherwise obscured.
- 1.8. Additional Questions:** Call the appropriate Wilkerson technical service department if you have any questions or require any additional information. See the Wilkerson publication for the product being considered or used, or call 269-629-2550, or go to www.wilkersoncorp.com, for telephone numbers of the appropriate technical service department.

2. PRODUCT SELECTION INSTRUCTIONS

- 2.1. Flow Rate:** The flow rate requirements of a system are frequently the primary consideration when designing any pneumatic system. System components need to be able to provide adequate flow and pressure for the desired application.
- 2.2. Pressure Rating:** Never exceed the rated pressure of a product. Consult product labeling, Pneumatic Division catalogs or the instruction sheets supplied for maximum pressure ratings.
- 2.3. Temperature Rating:** Never exceed the temperature rating of a product. Excessive heat can shorten the life expectancy of a product and result in complete product failure.
- 2.4. Environment:** Many environmental conditions can affect the integrity and suitability of a product for a given application. Pneumatic Division products are designed for use in general purpose industrial applications. If these products are to be used in unusual circumstances such as direct sunlight and / or corrosive or caustic environments, such use can shorten the useful life and lead to premature failure of a product.
- 2.5. Lubrication and Compressor Carryover:** Some modern synthetic oils can and will attack nitrile seals. If there is any possibility of synthetic oils or greases migrating into the pneumatic components check for compatibility with the seal materials used. Consult the factory or product literature for materials of construction.
- 2.6. Polycarbonate Bowls and Sight Glasses:** To avoid potential polycarbonate bowl failures:
 - Do not locate polycarbonate bowls or sight glasses in areas where they could be subject to direct sunlight, impact blow, or temperatures outside of the rated range.
 - Do not expose or clean polycarbonate bowls with detergents, chlorinated hydro-carbons, keytones, esters or certain alcohols.
 - Do not use polycarbonate bowls or sight glasses in air systems where compressors are lubricated with fire resistant fluids such as phosphate ester and di-ester lubricants.

2.7. Chemical Compatibility: For more information on plastic component chemical compatibility see Pneumatic Division technical bulletins Tec-3, Tec-4, and Tec-5

2.8. Product Rupture: Product rupture can cause death, serious personal injury, and property damage.

- Do not connect pressure regulators or other Pneumatic Division products to bottled gas cylinders.
- Do not exceed the maximum primary pressure rating of any pressure regulator or any system component.
- Consult product labeling or product literature for pressure rating limitations.

3. PRODUCT ASSEMBLY AND INSTALLATION INSTRUCTIONS

3.1. Component Inspection: Prior to assembly or installation a careful examination of the valves, FRLs or vacuum products must be performed. All components must be checked for correct style, size, and catalog number. DO NOT use any component that displays any signs of nonconformance.

3.2. Installation Instructions: Wilkerson published Installation Instructions must be followed for installation of Wilkerson valves, FRLs and vacuum components. These instructions are provided with every Wilkerson valve or FRL sold, or by calling 269-629-2550, or at www.wilkersoncorp.com.

3.3. Air Supply: The air supply or control medium supplied to Valves, FRLs and Vacuum components must be moisture-free if ambient temperature can drop below freezing

4. VALVE AND FRL MAINTENANCE AND REPLACEMENT INSTRUCTIONS

4.1. Maintenance: Even with proper selection and installation, valve, FRL and vacuum products service life may be significantly reduced without a continuing maintenance program. The severity of the application, risk potential from a component failure, and experience with any known failures in the application or in similar applications should determine the frequency of inspections and the servicing or replacement of Pneumatic Division products so that products are replaced before any failure occurs. A maintenance program must be established and followed by the user and, at minimum, must include instructions 4.2 through 4.10.

4.2. Installation and Service Instructions: Before attempting to service or replace any worn or damaged parts consult the appropriate Service Bulletin for the valve or FRL in question for the appropriate practices to service the unit in question. These Service and Installation Instructions are provided with every Wilkerson valve and FRL sold, or are available by calling 269-629-2550, or by accessing the Wilkerson web site at www.wilkersoncorp.com.

4.3. Lockout / Tagout Procedures: Be sure to follow all required lockout and tagout procedures when servicing equipment. For more information see: OSHA Standard – 29 CFR, Part 1910.147, Appendix A, The Control of Hazardous Energy – (Lockout / Tagout)

4.4. Visual Inspection: Any of the following conditions requires immediate system shut down and replacement of worn or damaged components:

- Air leakage: Look and listen to see if there are any signs of visual damage to any of the components in the system. Leakage is an indication of worn or damaged components.
- Damaged or degraded components: Look to see if there are any visible signs of wear or component degradation.
- Kinked, crushed, or damaged hoses. Kinked hoses can result in restricted air flow and lead to unpredictable system behavior.
- Any observed improper system or component function: Immediately shut down the system and correct malfunction.
- Excessive dirt build-up: Dirt and clutter can mask potentially hazardous situations.

Caution: Leak detection solutions should be rinsed off after use.

4.5. Routine Maintenance Issues:

- Remove excessive dirt, grime and clutter from work areas.
- Make sure all required guards and shields are in place.

4.6. Functional Test: Before initiating automatic operation, operate the system manually to make sure all required functions operate properly and safely.

4.7. Service or Replacement Intervals: It is the user's responsibility to establish appropriate service intervals. Valves, FRLs and vacuum products contain components that age, harden, wear, and otherwise deteriorate over time. Environmental conditions can significantly accelerate this process. Valves, FRLs and vacuum components need to be serviced or replaced on routine intervals. Service intervals need to be established based on:

- Previous performance experiences.
- Government and / or industrial standards.
- When failures could result in unacceptable down time, equipment damage or personal injury risk.

4.8. Servicing or Replacing of any Worn or Damaged Parts: To avoid unpredictable system behavior that can cause death, personal injury and property damage:

- Follow all government, state and local safety and servicing practices prior to service including but not limited to all OSHA Lockout Tagout procedures (OSHA Standard – 29 CFR, Part 1910.147, Appendix A, The Control of Hazardous Energy – Lockout / Tagout).
- Disconnect electrical supply (when necessary) before installation, servicing, or conversion.
- Disconnect air supply and depressurize all air lines connected to system and Pneumatic Division products before installation, service, or conversion.
- Installation, servicing, and / or conversion of these products must be performed by knowledgeable personnel who understand how pneumatic products are to be applied.
- After installation, servicing, or conversions air and electrical supplies (when necessary) should be connected and the product tested for proper function and leakage. If audible leakage is present, or if the product does not operate properly, do not put product or system into use.
- Warnings and specifications on the product should not be covered or painted over. If masking is not possible, contact your local representative for replacement labels.

4.9. Putting Serviced System Back into Operation: Follow the guidelines above and all relevant Installation and Maintenance Instructions supplied with the valve FRL or vacuum component to insure proper function of the system.

Offer of Sale

The items described in this document and other documents and descriptions provided by The Company, its subsidiaries and its authorized distributors ("Seller") are hereby offered for sale at prices to be established by Seller. This offer and its acceptance by any customer ("Buyer") shall be governed by all of the following Terms and Conditions. Buyer's order for any item described in its document, when communicated to Seller verbally, or in writing, shall constitute acceptance of this offer. All goods or work described will be referred to as "Products".

- 1. Terms and Conditions.** Seller's willingness to offer Products, or accept an order for Products, to or from Buyer is subject to these Terms and Conditions or any newer version of the terms and conditions found on-line at www.parker.com/salesterms/. Seller objects to any contrary or additional terms or conditions of Buyer's order or any other document issued by Buyer.
- 2. Price Adjustments; Payments.** Prices stated on Seller's quote or other documentation offered by Seller are valid for 30 days, and do not include any sales, use, or other taxes unless specifically stated. Unless otherwise specified by Seller, all prices are F.C.A. Seller's facility (INCOTERMS 2010). Payment is subject to credit approval and is due 30 days from the date of invoice or such other term as required by Seller's Credit Department, after which Buyer shall pay interest on any unpaid invoices at the rate of 1.5% per month or the maximum allowable rate under applicable law.
- 3. Delivery Dates; Title and Risk; Shipment.** All delivery dates are approximate and Seller shall not be responsible for any damages resulting from any delay. Regardless of the manner of shipment, title to any products and risk of loss or damage shall pass to Buyer upon placement of the products with the shipment carrier at Seller's facility. Unless otherwise stated, Seller may exercise its judgment in choosing the carrier and means of delivery. No deferment of shipment at Buyers' request beyond the respective dates indicated will be made except on terms that will indemnify, defend and hold Seller harmless against all loss and additional expense. Buyer shall be responsible for any additional shipping charges incurred by Seller due to Buyer's acts or omissions.
- 4. Warranty.** Seller warrants that the Products sold hereunder shall be free from defects in material or workmanship for a period of twelve months from the date of delivery to Buyer or 2,000 hours of normal use, whichever occurs first. The prices charged for Seller's products are based upon the exclusive limited warranty stated above, and upon the following disclaimer: **DISCLAIMER OF WARRANTY: THIS WARRANTY COMPRISES THE SOLE AND ENTIRE WARRANTY PERTAINING TO PRODUCTS PROVIDED HEREUNDER. SELLER DISCLAIMS ALL OTHER WARRANTIES, EXPRESS AND IMPLIED, INCLUDING DESIGN, MERCHANTABILITY AND FITNESS FOR A PARTICULAR PURPOSE.**
- 5. Claims; Commencement of Actions.** Buyer shall promptly inspect all Products upon delivery. No claims for shortages will be allowed unless reported to the Seller within 10 days of delivery. No other claims against Seller will be allowed unless asserted in writing within 30 days after delivery. Buyer shall notify Seller of any alleged breach of warranty within 30 days after the date the defect is or should have been discovered by Buyer. Any action based upon breach of this agreement or upon any other claim arising out of this sale (other than an action by Seller for an amount due on any invoice) must be commenced within 12 months from the date of the breach without regard to the date breach is discovered.
- 6. LIMITATION OF LIABILITY.** UPON NOTIFICATION, SELLER WILL, AT ITS OPTION, REPAIR OR REPLACE A DEFECTIVE PRODUCT, OR REFUND THE PURCHASE PRICE. **IN NO EVENT SHALL SELLER BE LIABLE TO BUYER FOR ANY SPECIAL, INDIRECT, INCIDENTAL OR CONSEQUENTIAL DAMAGES ARISING OUT OF, OR AS THE RESULT OF, THE SALE, DELIVERY, NON-DELIVERY, SERVICING, USE OR LOSS OF USE OF THE PRODUCTS OR ANY PART THEREOF, OR FOR ANY CHARGES OR EXPENSES OF ANY NATURE INCURRED WITHOUT SELLER'S WRITTEN CONSENT, EVEN IF SELLER HAS BEEN NEGLIGENT, WHETHER IN CONTRACT, TORT OR OTHER LEGAL THEORY. IN NO EVENT SHALL SELLER'S LIABILITY UNDER ANY CLAIM MADE BY BUYER EXCEED THE PURCHASE PRICE OF THE PRODUCTS.**
- 7. User Responsibility.** The user, through its own analysis and testing, is solely responsible for making the final selection of the system and Product and assuring that all performance, endurance, maintenance, safety and warning requirements of the application are met. The user must analyze all aspects of the application and follow applicable industry standards and Product information. If Seller provides Product or system options, the user is responsible for determining that such data and specifications are suitable and sufficient for all applications and reasonably foreseeable uses of the Products or systems.
- 8. Loss to Buyer's Property.** Any designs, tools, patterns, materials, drawings, confidential information or equipment furnished by Buyer or any other items which become Buyer's property, may be considered obsolete and may be destroyed by Seller after two consecutive years have elapsed without Buyer ordering the items manufactured using such property. Seller shall not be responsible for any loss or damage to such property while it is in Seller's possession or control.
- 9. Special Tooling.** A tooling charge may be imposed for any special tooling, including without limitation, dies, fixtures, molds and patterns, acquired to manufacture Products. Such special tooling shall be and remain Seller's property notwithstanding payment of any charges by Buyer. In no event will Buyer acquire any interest in apparatus belonging to Seller which is utilized in the manufacture of the Products, even if such apparatus has been specially converted or adapted for such manufacture and notwithstanding any charges paid by Buyer. Unless otherwise agreed, Seller shall have the right to alter, discard or otherwise dispose of any special tooling or other property in its sole discretion at any time.
- 10. Buyer's Obligation; Rights of Seller.** To secure payment of all sums due or otherwise, Seller shall retain a security interest in the goods delivered and this agreement shall be deemed a Security Agreement under the Uniform Commercial Code. Buyer authorizes Seller as its attorney to execute and file on Buyer's behalf all documents Seller deems necessary to perfect its security interest.
- 11. Improper use and Indemnity.** Buyer shall indemnify, defend, and hold Seller harmless from any claim, liability, damages, lawsuits, and costs (including attorney fees), whether for personal injury, property damage, patent, trademark or copyright infringement or any other

claim, brought by or incurred by Buyer, Buyer's employees, or any other person, arising out of: (a) improper selection, improper application or other misuse of Products purchased by Buyer from Seller; (b) any act or omission, negligent or otherwise, of Buyer; (c) Seller's use of patterns, plans, drawings, or specifications furnished by Buyer to manufacture Product; or (d) Buyer's failure to comply with these terms and conditions. Seller shall not indemnify Buyer under any circumstance except as otherwise provided.

12. Cancellations and Changes. Orders shall not be subject to cancellation or change by Buyer for any reason, except with Seller's written consent and upon terms that will indemnify, defend and hold Seller harmless against all direct, incidental and consequential loss or damage. Seller may change product features, specifications, designs and availability with notice to Buyer.

13. Limitation on Assignment. Buyer may not assign its rights or obligations under this agreement without the prior written consent of Seller.

14. Force Majeure. Seller does not assume the risk and shall not be liable for delay or failure to perform any of Seller's obligations by reason of circumstances beyond the reasonable control of Seller (hereinafter "Events of Force Majeure") Events of Force Majeure shall include without limitation: accidents, strikes or labor disputes, acts of any government or government agency, acts of nature, delays or failures in delivery from carriers or suppliers, shortages of materials, or any other cause beyond Seller's reasonable control.

15. Waiver and Severability. Failure to enforce any provision of this agreement will not waive that provision nor will any such failure prejudice Seller's right to enforce that provision in the future. Invalidation of any provision of this agreement by legislation or other rule of law shall not invalidate any other provision herein. The remaining provisions of this agreement will remain in full force and effect.

16. Termination. Seller may terminate this agreement for any reason and at any time by giving Buyer thirty (30) days written notice of termination. Seller may immediately terminate this agreement, in writing, if Buyer: (a) commits a breach of any provision of this agreement (b) appoints a trustee, receiver or custodian for all or any part of Buyer's property (c) files a petition for relief in bankruptcy on its own behalf, or by a third party (d) makes an assignment for the benefit of creditors, or (e) the dissolves or liquidates all or a majority of its assets.

17. Governing Law. This agreement and the sale and delivery of all Products hereunder shall be deemed to have taken place in and shall be governed and construed in accordance with the laws of the State of Ohio, as applicable to contracts executed and wholly performed therein and without regard to conflicts of laws principles. Buyer irrevocably agrees and consents to the exclusive jurisdiction and venue of the courts of Cuyahoga County, Ohio with respect to any dispute, controversy or claim arising out of or relating to this agreement.

18. Indemnity for Infringement of Intellectual Property Rights. Seller shall have no liability for infringement of any patents, trademarks, copyrights, trade dress, trade secrets or similar rights except as provided in this Section. Seller will defend and indemnify Buyer against allegations of infringement of U.S. patents, U.S. trademarks, copyrights, trade dress and trade secrets ("Intellectual Property Rights"). Seller will defend at its expense and will pay the cost of any settlement or damages awarded in an action brought against Buyer based on an allegation that a Product sold pursuant to this Agreement infringes the Intellectual Property Rights of a third party. Seller's obligation to defend and indemnify Buyer is contingent on Buyer notifying Seller within ten (10) days after Buyer becomes aware of such allegations of infringement, and Seller having sole control over the defense of any allegations or actions including all negotiations for settlement or compromise. If a Product is subject to a claim that it infringes the Intellectual Property Rights of a third party, Seller may, at its sole expense and option, procure for Buyer the right to continue using the Product, replace or modify the Product so as to make it noninfringing, or offer to accept return of the Product and return the purchase price less a reasonable allowance for depreciation. Notwithstanding the foregoing, Seller shall have no liability for claims of infringement based on information provided by Buyer, or directed to Products delivered hereunder for which the designs are specified in whole or part by Buyer, or infringements resulting from the modification, combination or use in a system of any Product sold hereunder. The foregoing provisions of this Section shall constitute Seller's sole and exclusive liability and Buyer's sole and exclusive remedy for infringement of Intellectual Property Rights.

19. Entire Agreement. This agreement contains the entire agreement between the Buyer and Seller and constitutes the final, complete and exclusive expression of the terms of sale. All prior or contemporaneous written or oral agreements or negotiations with respect to the subject matter are herein merged.

20. Compliance with Law, U. K. Bribery Act and U.S. Foreign Corrupt Practices Act. Buyer agrees to comply with all applicable laws and regulations, including both those of the United Kingdom and the United States of America, and of the country or countries of the Territory in which the Buyer may operate, including without limitation the U. K. Bribery Act, the U.S. Foreign Corrupt Practices Act ("FCPA") and the U.S. Anti-Kickback Act (the "Anti-Kickback Act"), and agrees to indemnify and hold harmless Seller from the consequences of any violation of such provisions by Buyer, its employees or agents. Buyer acknowledges that they are familiar with the provisions of the U. K. Bribery Act, the FCPA and the Anti-Kickback Act, and certifies that Buyer will adhere to the requirements thereof. In particular, Buyer represents and agrees that Buyer shall not make any payment or give anything of value, directly or indirectly to any governmental official, any foreign political party or official thereof, any candidate for foreign political office, or any commercial entity or person, for the purpose of influencing such person to purchase products or otherwise benefit the business of Seller.

02/12

Other Wilkerson Products

Miniature FRL Products



Stainless Steel FRL Products



Precision Regulator Products



Dryer Products



Heavy Duty FRL Products



WILKERSON®

Pneumatic Division
8676 E. M89
P.O. Box 901
Richland, MI 49083 USA

Applications Engineering
Phone: 877-321-4736 Option #2
E-mail: pdnapps@parker.com
Customer Support
Phone: 877-321-4736 Option #1
E-mail: wilkerson_sales@parker.com