

MTH PUMPS

E41 • T41 Series - 50Hz Metric Edition

- Capacities to 75 LPM
- Heads to 135 Meters
- Low NPSH Requirements
- Horizontal Close Coupled
- Vertical Flange Mounted
- Flex Coupled

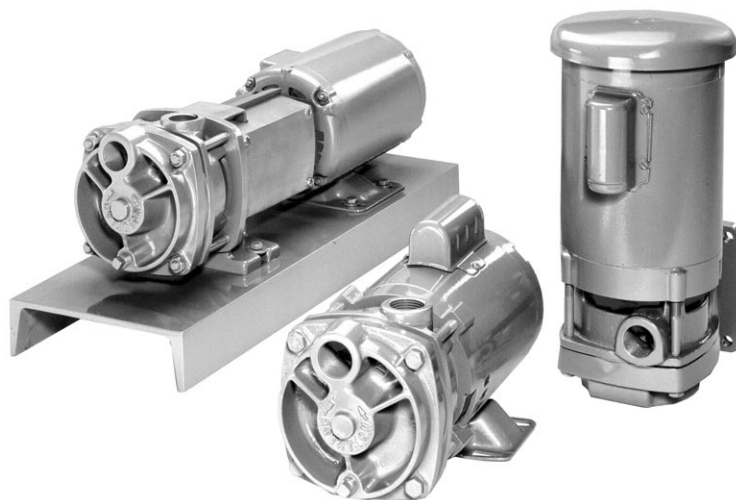

E41 • T41 SERIES

Composite Curves

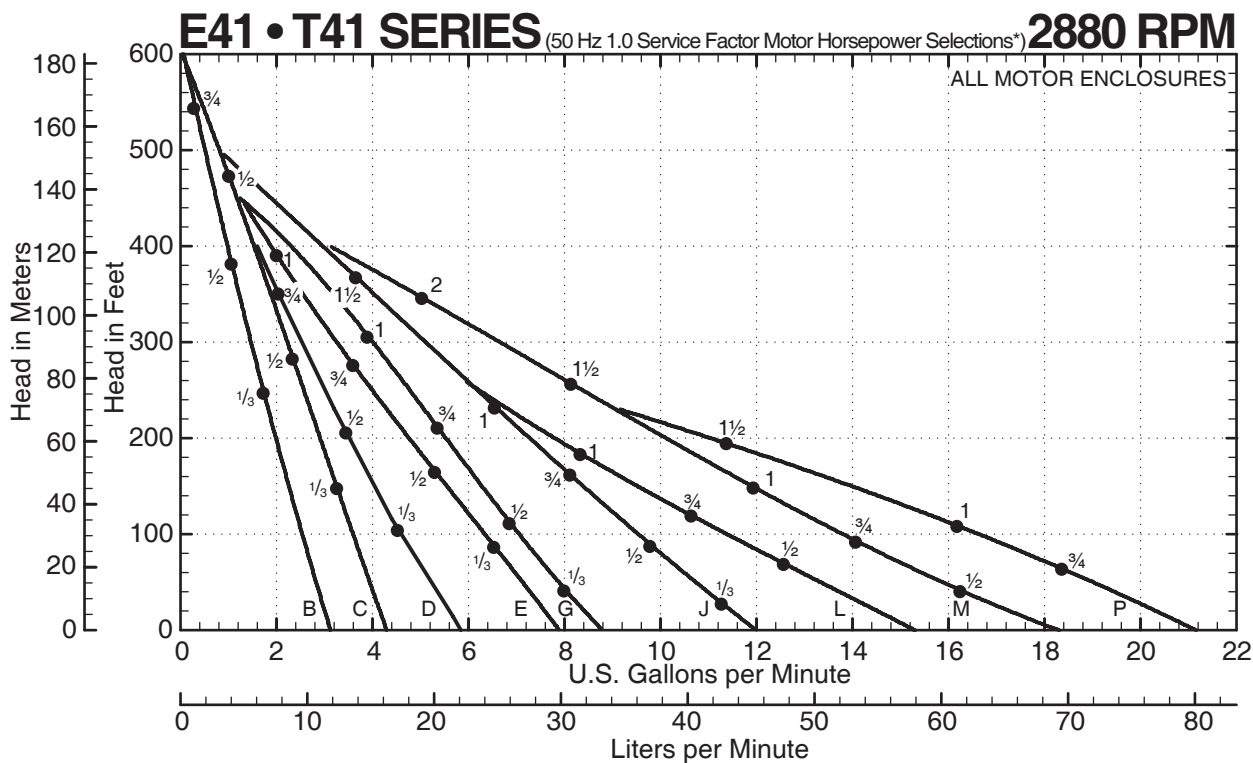

* Horsepower data is valid for 1.0 specific gravity fluids only

MTH PUMPS
 401 West Main Street • Plano, IL 60545-1436
 Phone: 630-552-4115 • Fax: 630-552-3688
 Email: SALES@MTHPUMPS.COM
 http://WWW.MTHPUMPS.COM

E41 • T41 SERIES PUMPS

Performance Curves

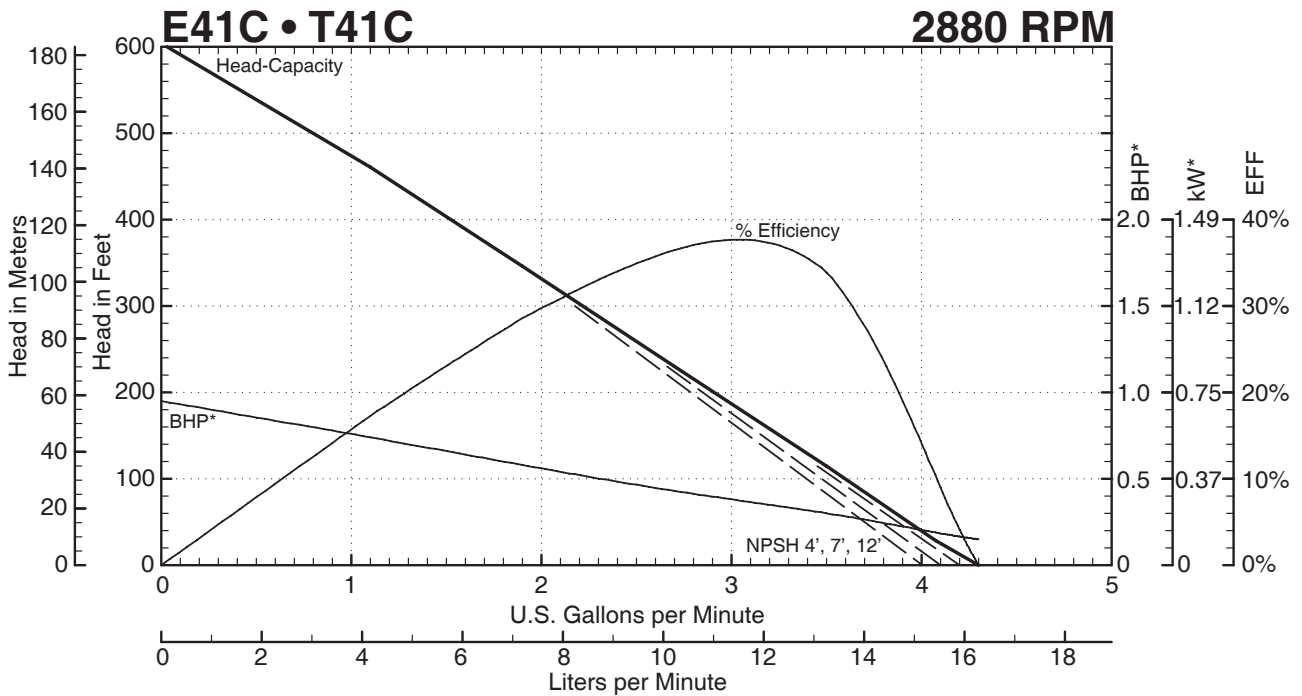
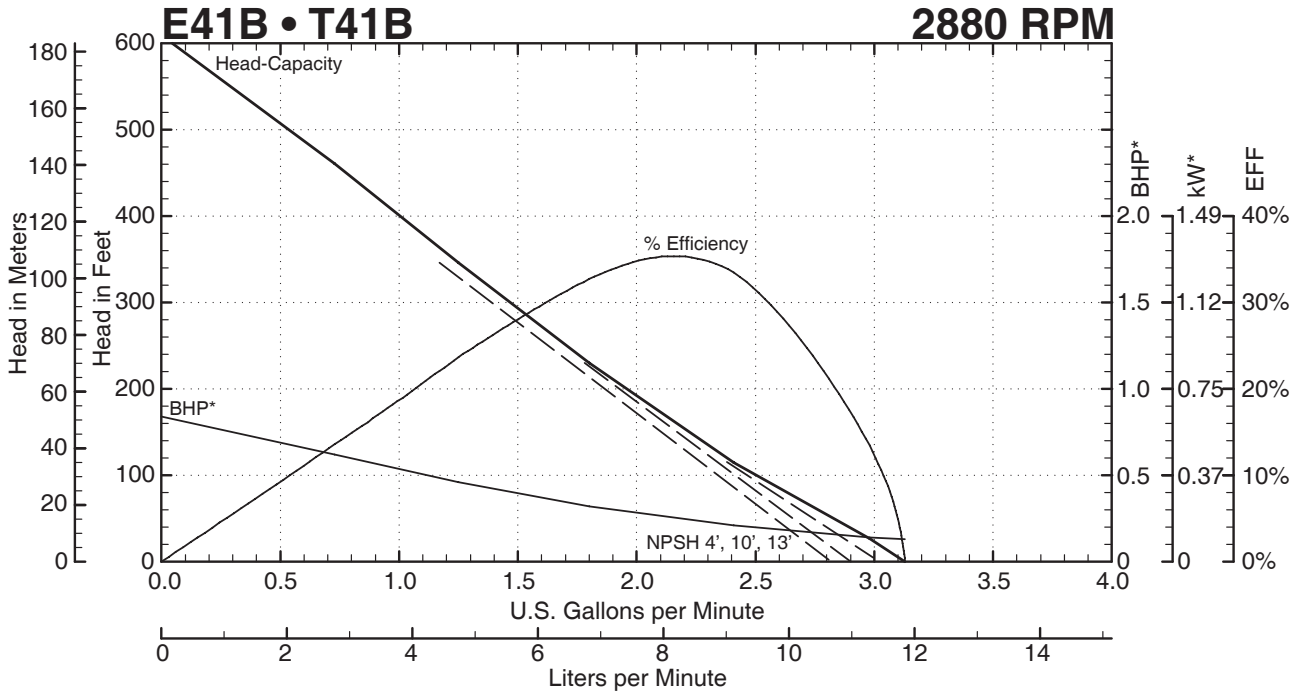

E41 • T41 SERIES PUMPS



MTH PUMPS

401 West Main Street • Plano, IL 60545-1436
 Phone: 630-552-4115 • Fax: 630-552-3688
 Email: SALES@MTHPUMPS.COM
 http://WWW.MTHPUMPS.COM

— — — Indicates altered performance at NPSH Available
 * Horsepower data is valid for 1.0 specific gravity fluids only

E41 • T41 SERIES

Performance Curves

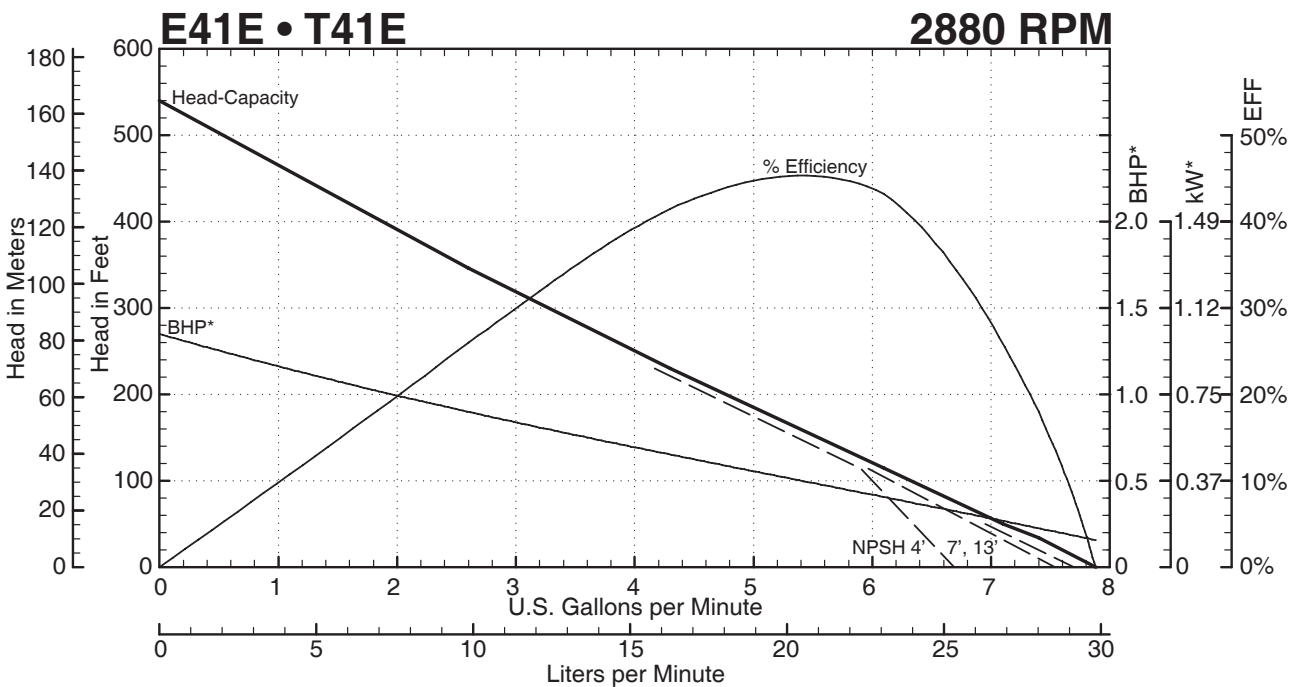
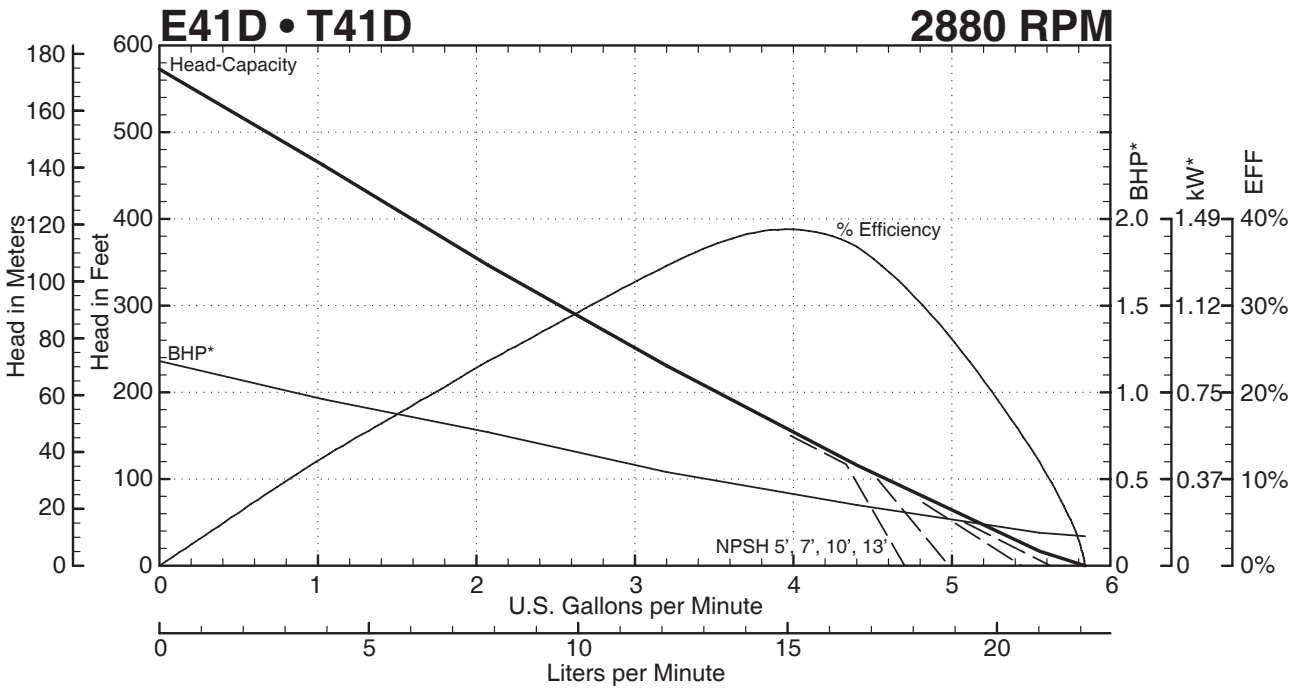

— — — Indicates altered performance at NPSH Available
 * Horsepower data is valid for 1.0 specific gravity fluids only



401 West Main Street • Plano, IL 60545-1436
 Phone: 630-552-4115 • Fax: 630-552-3688
 Email: SALES@MTHPUMPS.COM
 http://WWW.MTHPUMPS.COM

Performance Curves

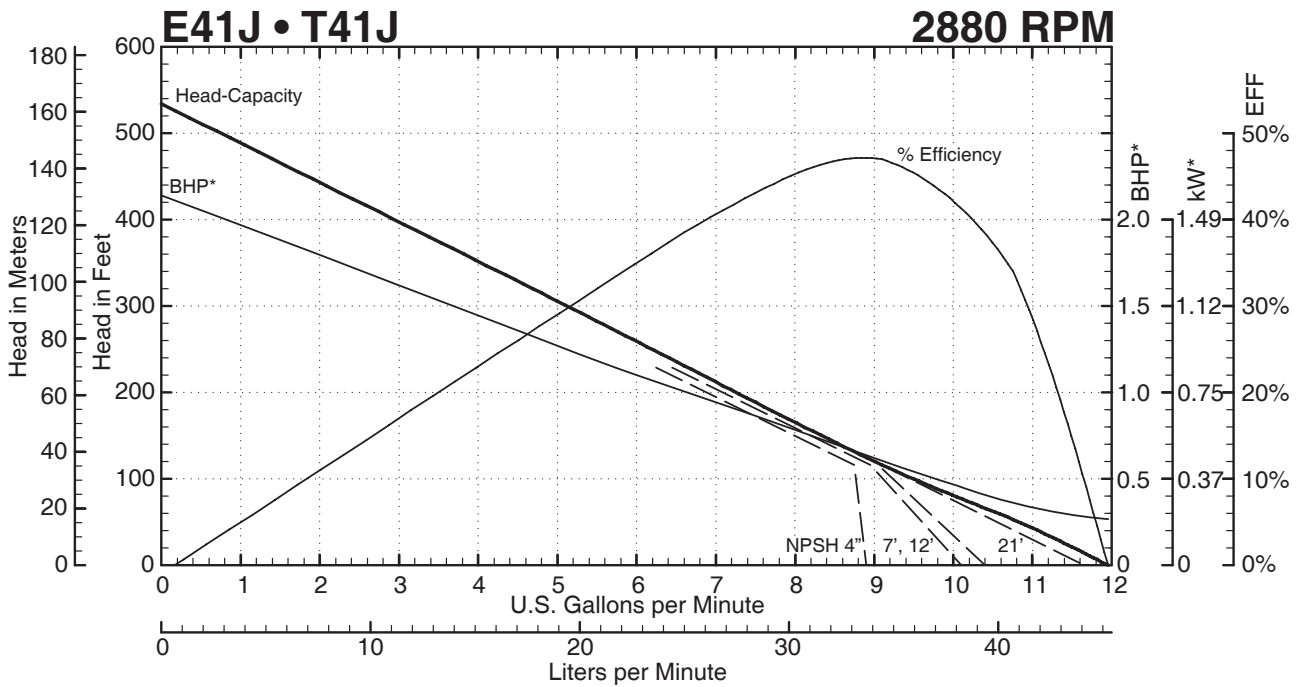
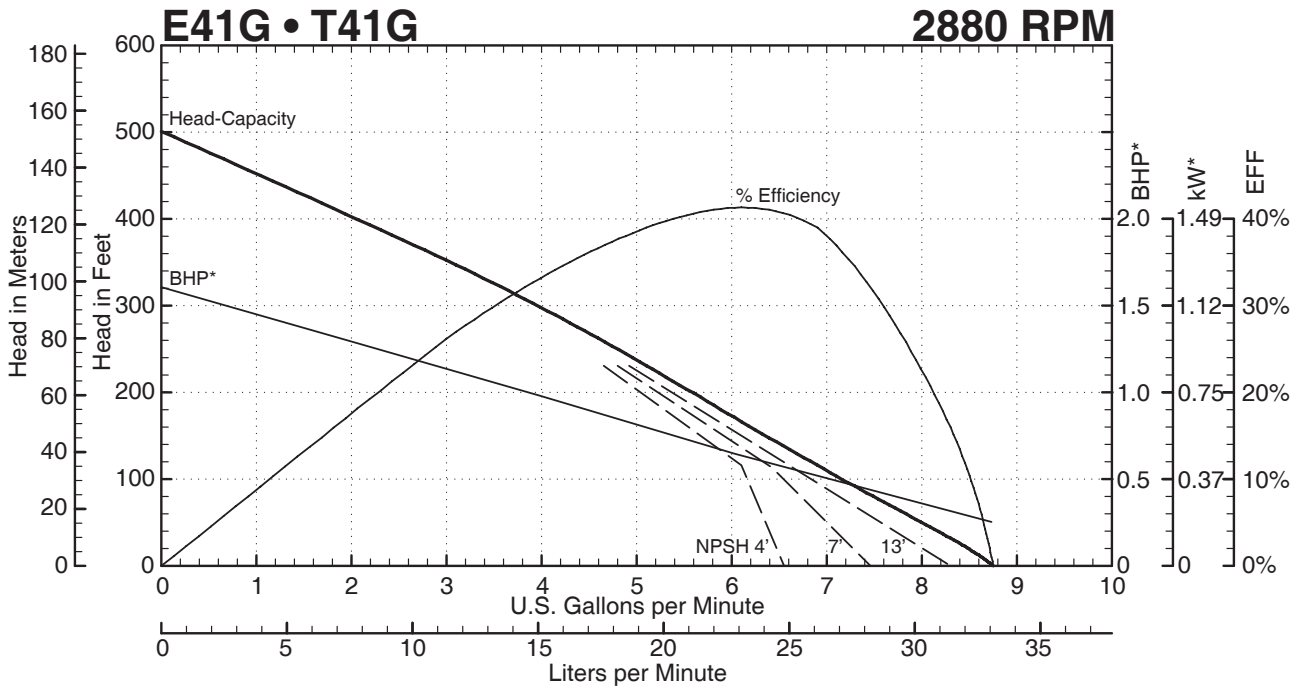

E41 • T41 SERIES PUMPS



MTH PUMPS

401 West Main Street • Plano, IL 60545-1438
 Phone: 630-552-4115 • Fax: 630-552-3688
 Email: SALES@MTHPUMPS.COM
 http://WWW.MTHPUMPS.COM

— — — Indicates altered performance at NPSH Available
 * Horsepower data is valid for 1.0 specific gravity fluids only

E41 • T41 SERIES

Performance Curves

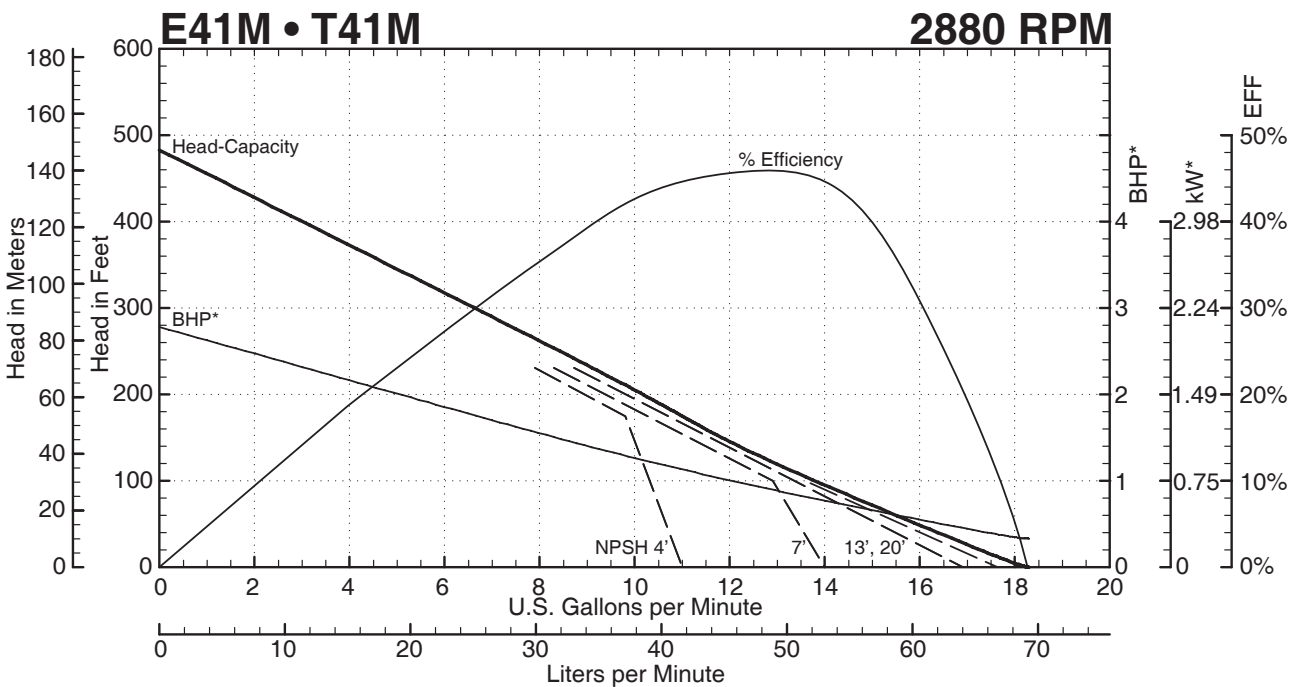
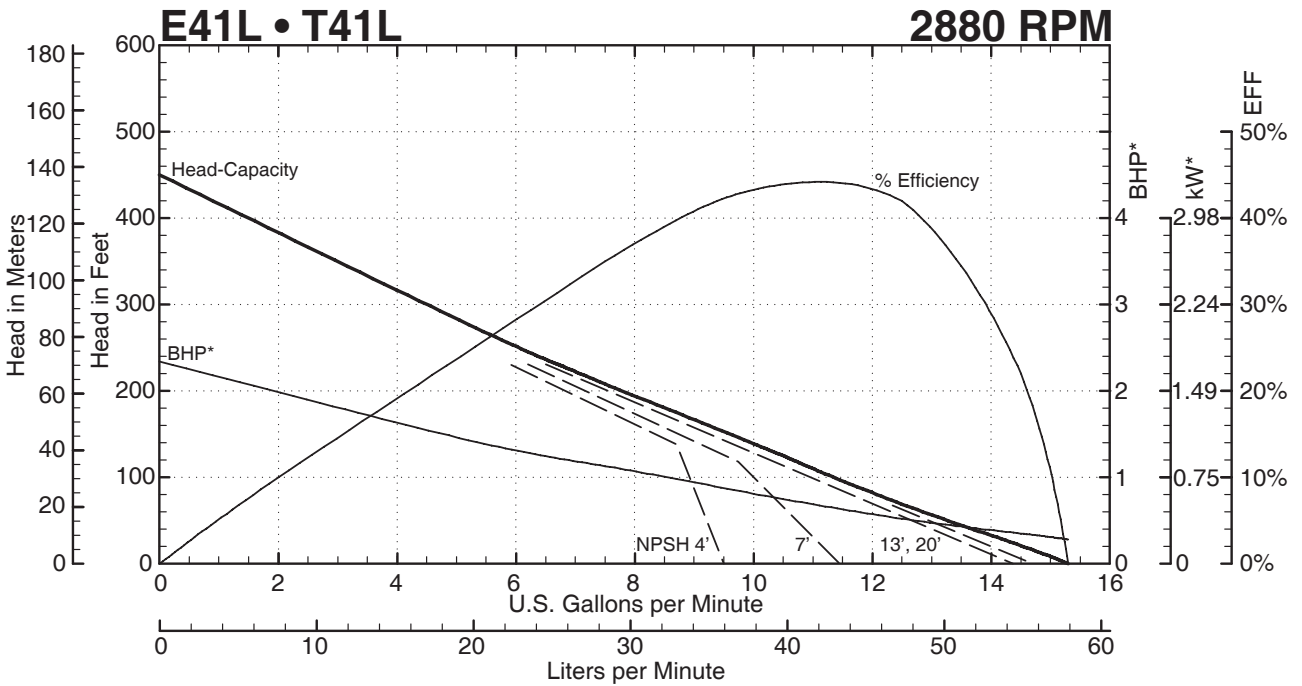

— — — Indicates altered performance at NPSH Available
* Horsepower data is valid for 1.0 specific gravity fluids only

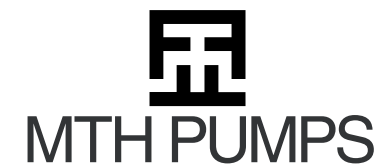

401 West Main Street • Plano, IL 60545-1436
Phone: 630-552-4115 • Fax: 630-552-3688
Email: SALES@MTHPUMPS.COM
http://WWW.MTHPUMPS.COM

E41 • T41 SERIES

Performance Curves

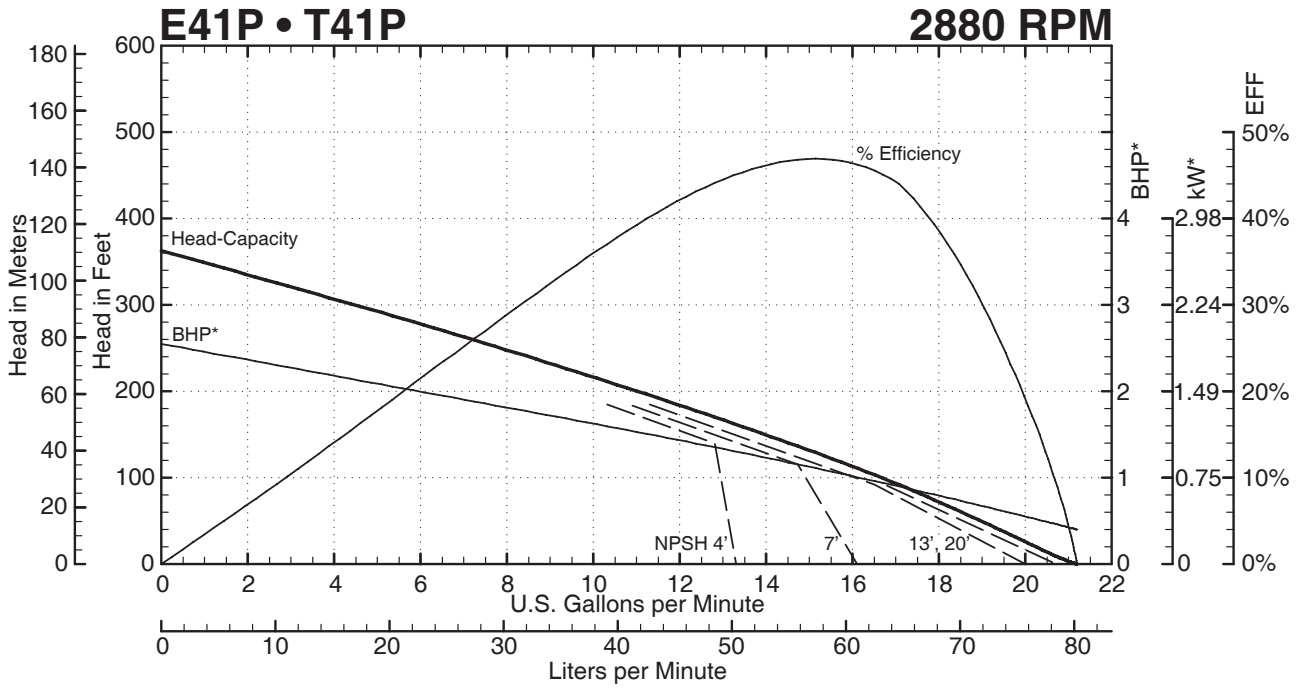

E41 • T41 SERIES PUMPS



MTH PUMPS

401 West Main Street • Plano, IL 60545-1436
 Phone: 630-552-4115 • Fax: 630-552-3688
 Email: SALES@MTHPUMPS.COM
 http://WWW.MTHPUMPS.COM

— — — — — Indicates altered performance at NPSH Available
 * Horsepower data is valid for 1.0 specific gravity fluids only

E41 • T41 SERIES
Dimensions

T41 Horizontal Close Coupled

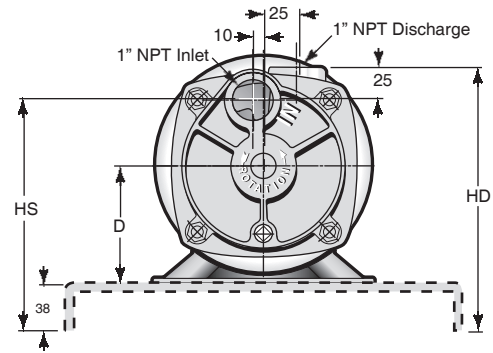
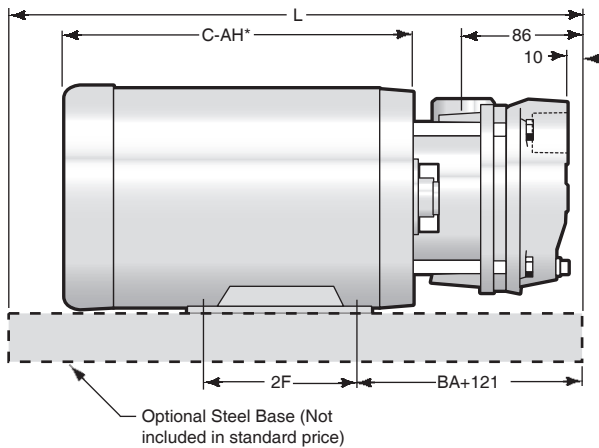
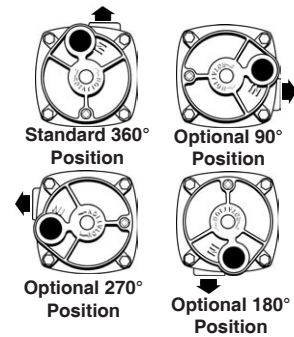
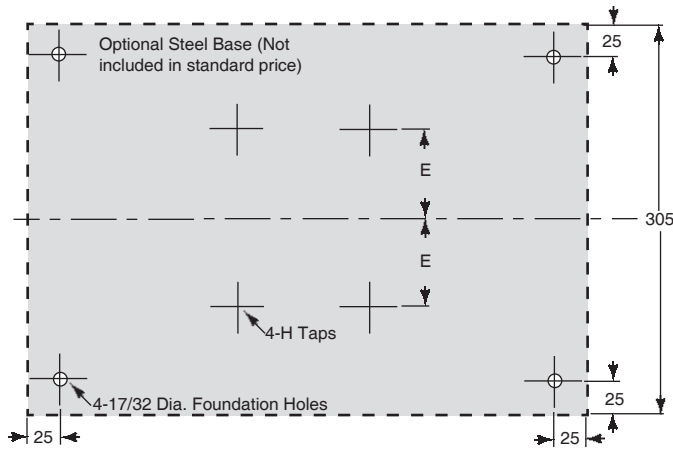

56C Thru 215TC Motor Frames

FRAME	D	BA+4 3/4	2F	E	H	HS	HD	L
56 C	89	187	76	62	5/16 - 18	178	203	457
143 TC	89	194	102	70	5/16 - 18	178	203	457
145 TC	89	194	127	70	5/16 - 18	178	203	457
182 TC	114	213	114	95	3/8 - 16	203	229	508
184 TC	114	213	140	95	3/8 - 16	203	229	508
213 TC	133	232	140	108	3/8 - 16	222	248	559
215 TC	133	232	178	108	3/8 - 16	222	248	559

NOTES

All dimensions in millimeters. May vary ± 6 MM.
 Not for construction purposes unless certified.
 *See motor dimensions for "C-AH" dimension
 (varies depending on motor enclosure).



401 West Main Street • Plano, IL 60545-1436
 Phone: 630-552-4115 • Fax: 630-552-3688
 Email: SALES@MTHPUMPS.COM
 http://WWW.MTHPUMPS.COM

Dimensions

T41 Flange Mounted Close Coupled

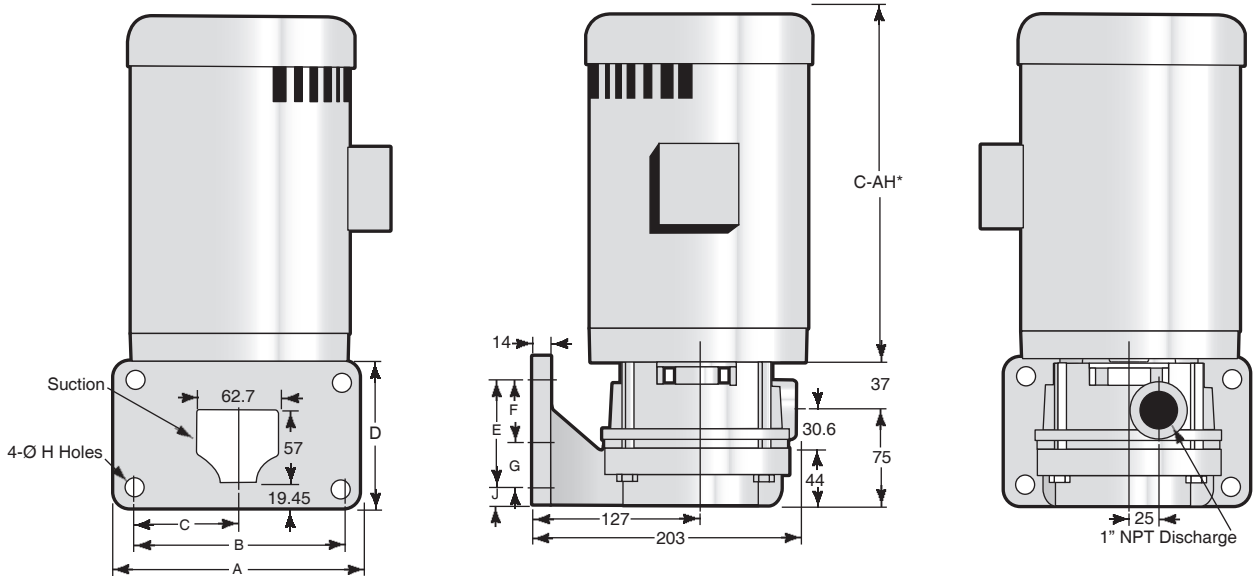

56C Thru 215TC Motor Frames

FLANGE STYLE	A	B	C	D	E	F	G	H	J
AU (7 1/2 x 4 1/2)	191	159	79	114	83	54	29	14	16
DB (4 1/2 x 4 1/2)	114	83	42	114	83	54	29	13	16
FE (7 3/4 x 4 3/4)	191	159	79	114	89	57	32	14	13
PA (6 1/2 x 3 3/4)	165	140	70	95	67	38	29	14	16
SH & BU (6 1/4 x 4)	159	127	64	102	70	41	29	14	16
SK (6 1/8 x 4 1/8)	156	125	63	105	68	42	26	14	18
ST (5 x 5)	127	95	48	127	95	67	29	13	16
WI (5 x 5)	127	105	53	127	105	71	33	11	11

NOTES

All dimensions in millimeters. May vary ± 6 MM.
 Not for construction purposes unless certified.
 *See motor dimensions for "C-AH" dimension
 (varies depending on motor enclosure).

E41 • T41 SERIES PUMPS



MTH PUMPS

401 West Main Street • Plano, IL 60545-1436
 Phone: 630-552-4115 • Fax: 630-552-3688
 Email: SALES@MTHPUMPS.COM
 http://WWW.MTHPUMPS.COM

E41 • T41 SERIES
Dimensions

P3 Bearing Pedestal

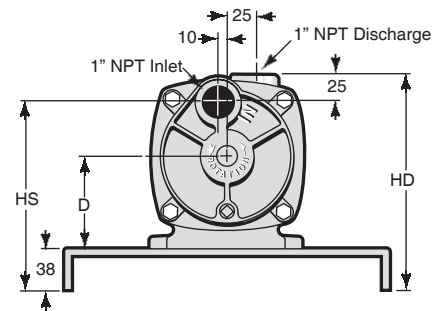
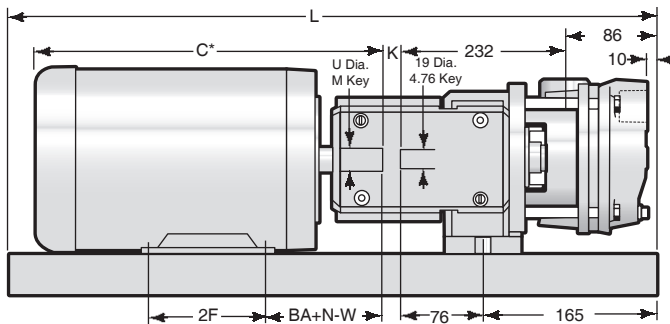
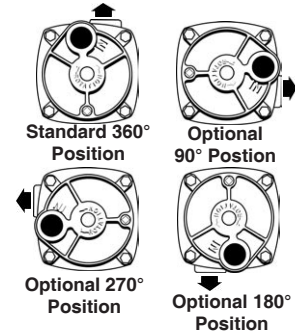
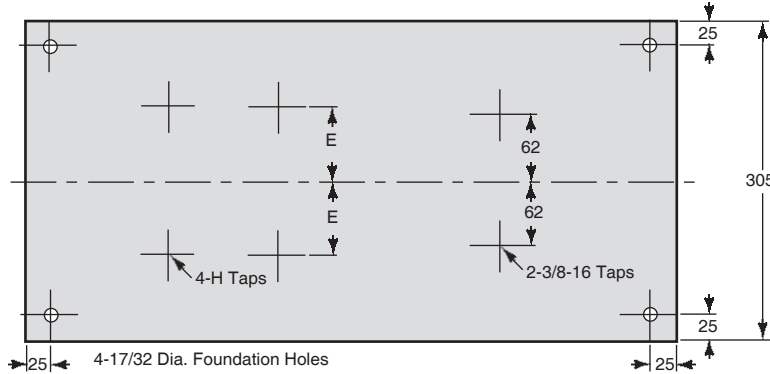

56T Thru 184T Motor Frames

FRAME	D	U	BA+N-W	2F	E	H	K	HS	HD	L	M
56 T	89	16	117	76	62	5/16 - 18	16	178	203	610	5
143 T	89	22	114	102	70	5/16 - 18	16	178	203	610	5
145 T	89	22	114	127	70	5/16 - 18	16	178	203	610	5
182 T	114	29	140	114	95	3/8 - 16	19	203	229	660	6
184 T	114	29	140	140	95	3/8 - 16	19	203	229	660	6

NOTES

All dimensions in millimeters. May vary ± 6 MM.
 Not for construction purposes unless certified.
 *See motor dimensions for "C" dimension
 (varies depending on motor enclosure).



401 West Main Street • Plano, IL 60545-1436
 Phone: 630-552-4115 • Fax: 630-552-3688
 Email: SALES@MTHPUMPS.COM
 http://WWW.MTHPUMPS.COM

Dimensions

P15 Bearing Pedestal

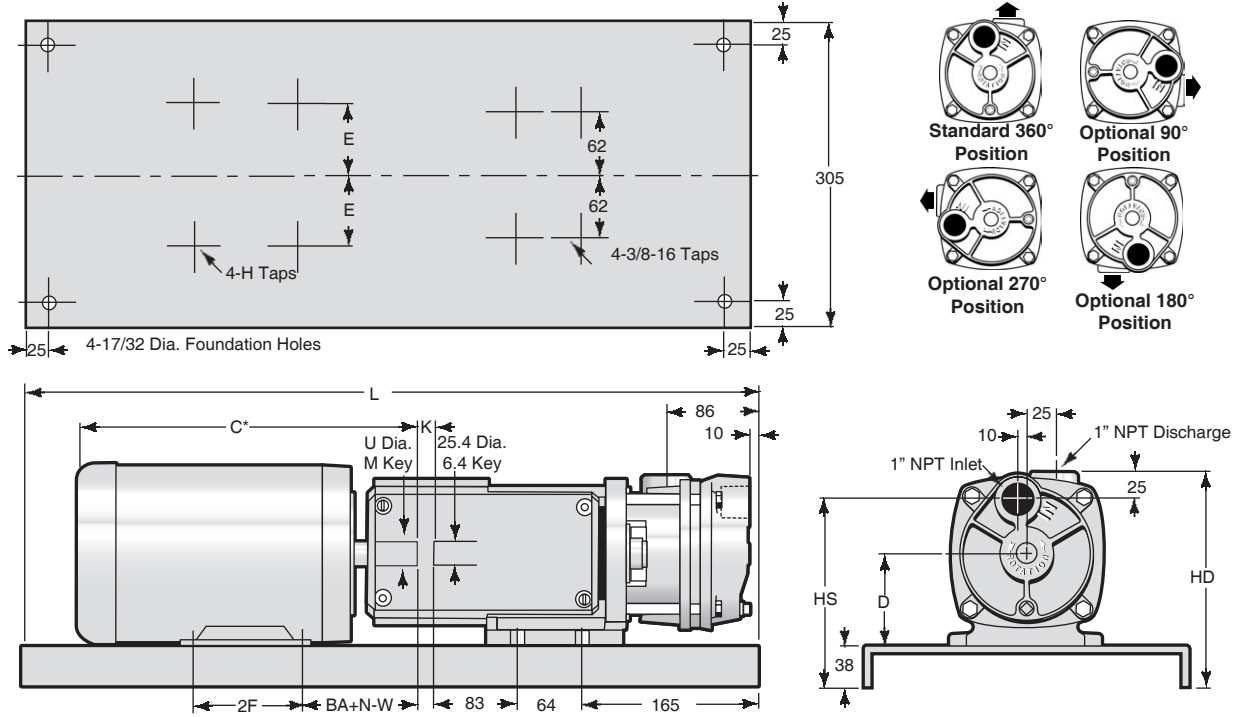

143T Thru 215T Motor Frames

FRAME	D	U	BA+N-W	2F	E	H	K	HS	HD	L	M
143 T	89	22	114	102	70	5/16 - 18	16	178	203	711	5
145 T	89	22	114	127	70	5/16 - 18	16	178	203	711	5
182 T	114	29	140	114	95	3/8 - 16	19	203	229	762	6
184 T	114	29	140	140	95	3/8 - 16	19	203	229	762	6
213 T	133	35	175	140	108	3/8 - 16	22	222	248	838	8
215 T	133	35	175	178	108	3/8 - 16	22	222	248	838	8

NOTES

All dimensions in millimeters. May vary ± 6 MM.
 Not for construction purposes unless certified.
 *See motor dimensions for "C" dimension
 (varies depending on motor enclosure).

E41 • T41 SERIES PUMPS



401 West Main Street • Plano, IL 60545-1436
 Phone: 630-552-4115 • Fax: 630-552-3688
 Email: SALES@MTHPUMPS.COM
 http://WWW.MTHPUMPS.COM

E41 • T41 SERIES

Dimensions

E41 Horizontal Close Coupled

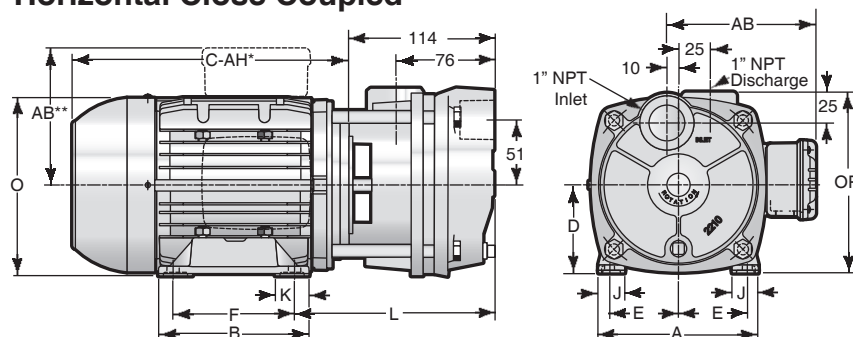

48 Thru 90 Motor Frames

FRAME	A	AB	B	D	E	F	J	K	L	O	OP
48	156	---	90	76	54	69	---	---	180	143	152
56	166	---	165	89	62	76	---	---	196	166	165
71	134	127	108	71	56	90	28	30	166	139	147
80	155	130	124	80	62	100	32	28	170	157	156
90	170	150**	146	90	70	125	35	---	178	177	166

**denotes conduit box mounted on top(90 frame only)

E41 Vertical Close Coupled

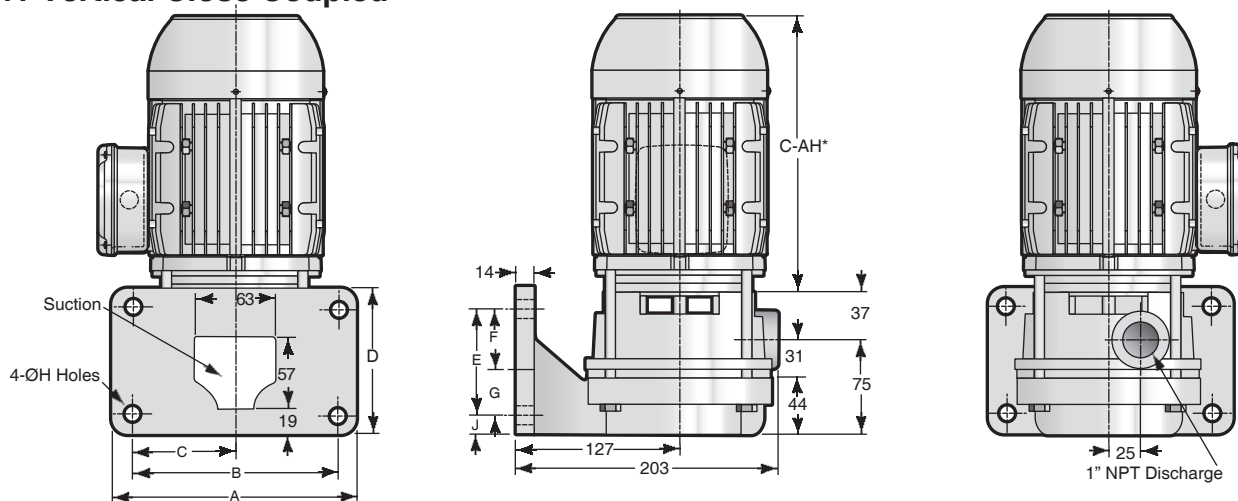

48 Thru 90 Motor Frames

FLANGE STYLE	A	B	C	D	E	F	G	H	J
AU (7 1/2 x 4 1/2)	191	159	79	114	83	54	29	14	16
DB (4 1/2 x 4 1/2)	114	83	42	114	83	54	29	13	16
FE (7 3/4 x 4 3/4)	191	159	79	114	89	57	32	14	13
PA (6 1/2 x 3 3/4)	165	140	70	95	67	38	29	14	16
SH & BU (6 1/4 x 4)	159	127	64	102	70	41	29	14	16
SK (6 1/8 x 4 1/8)	156	125	63	105	68	42	26	14	18
ST (5 x 5)	127	95	48	127	95	67	29	13	16
WI (5 x 5)	127	105	53	127	105	71	33	11	11

NOTES

All dimensions in millimeters. May vary ± 6 MM.
 Not for construction purposes unless certified.
 *See motor dimensions for "C-AH" dimension
 (varies depending on motor enclosure).



MTH PUMPS

401 West Main Street • Plano, IL 60545-1436
 Phone: 630-552-4115 • Fax: 630-552-3688
 Email: SALES@MTHPUMPS.COM
 http://WWW.MTHPUMPS.COM