

MTH PUMPS

E51 • T51 Series - 50Hz Metric Edition

- Capacities to 120 LPM
- Heads to 213 Meters
- Low NPSH Requirements
- Horizontal Close Coupled
- Vertical Flange Mounted
- Flex Coupled

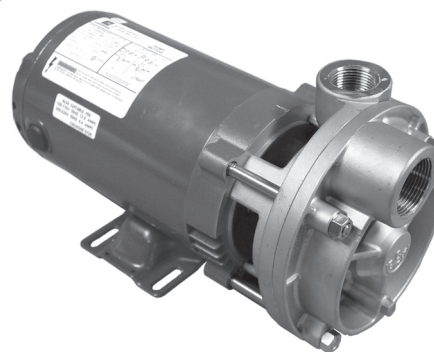
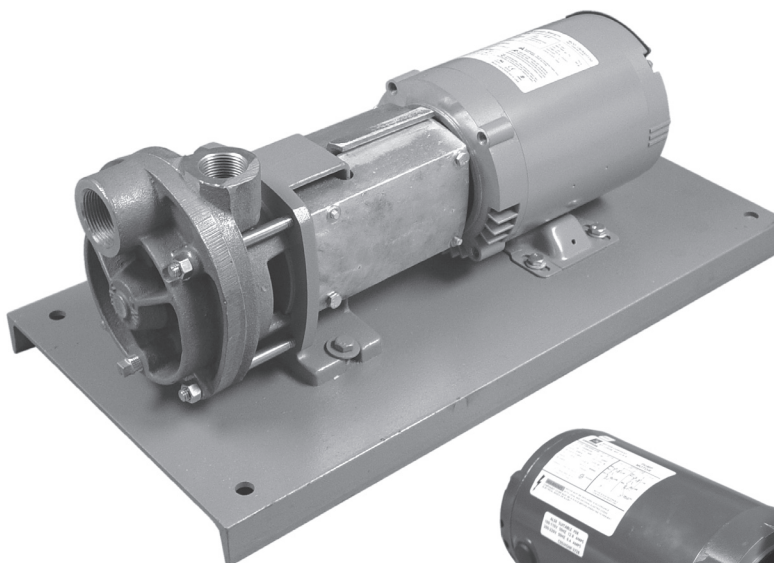

E51 • T51 SERIES PUMPS

E51 • T51 SERIES

Composite Curves

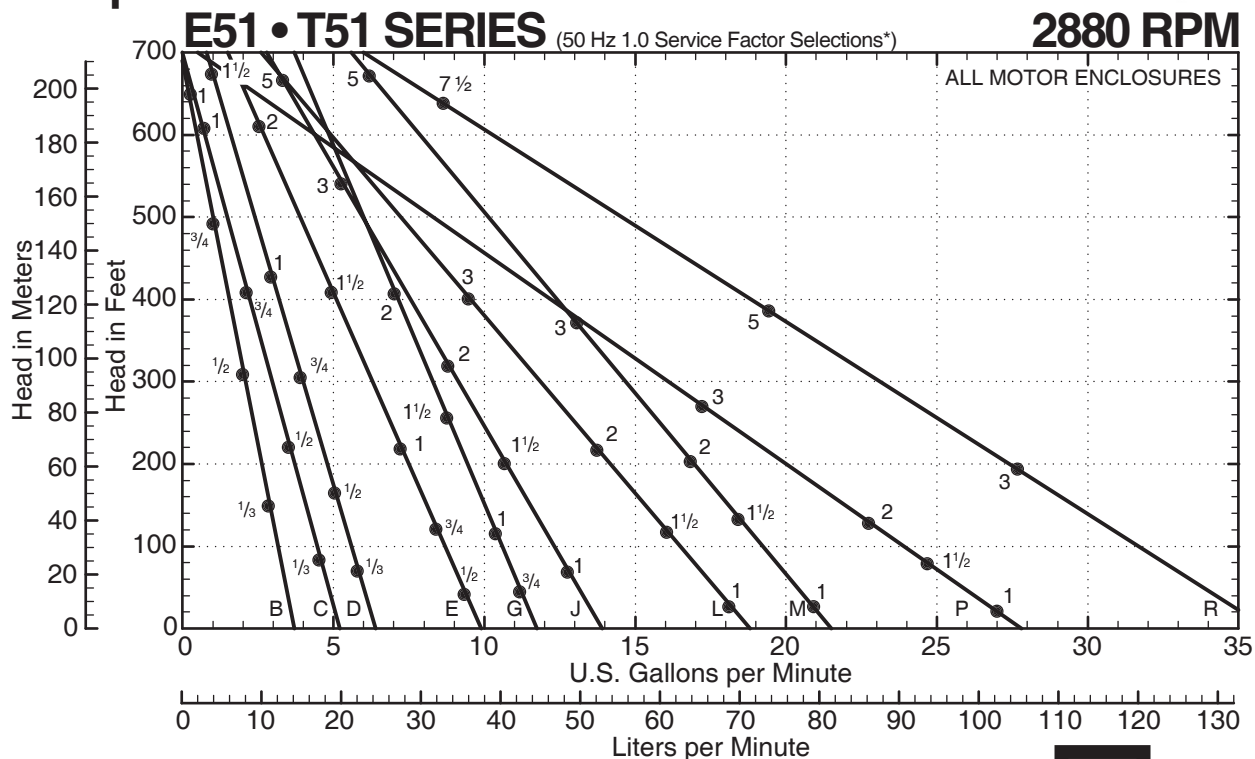

* Horsepower data is valid for 1.0 specific gravity fluids only



MTH PUMPS

401 West Main Street • Plano, IL 60545-1436
 Phone: 630-552-4115 • Fax: 630-552-3688
 Email: SALES@MTHPUMPS.COM
<http://WWW.MTHPUMPS.COM>

T51 SERIES

Performance Curves

E51 • T51 SERIES PUMPS

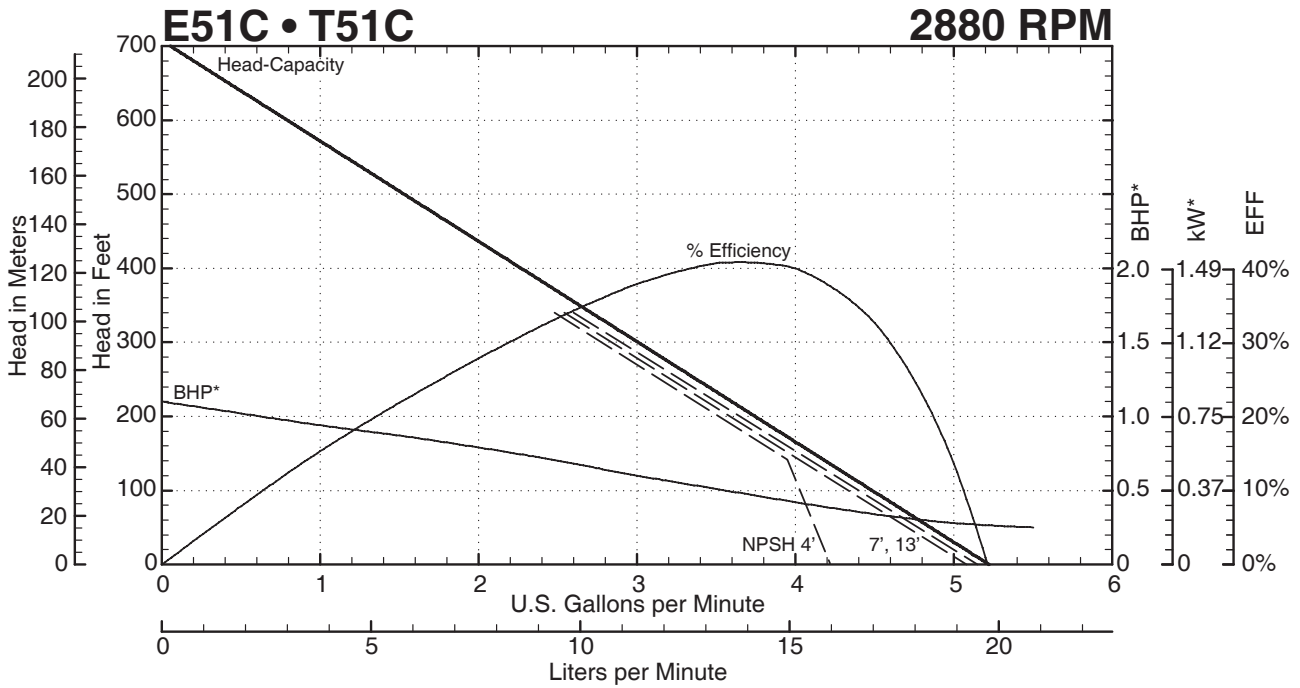
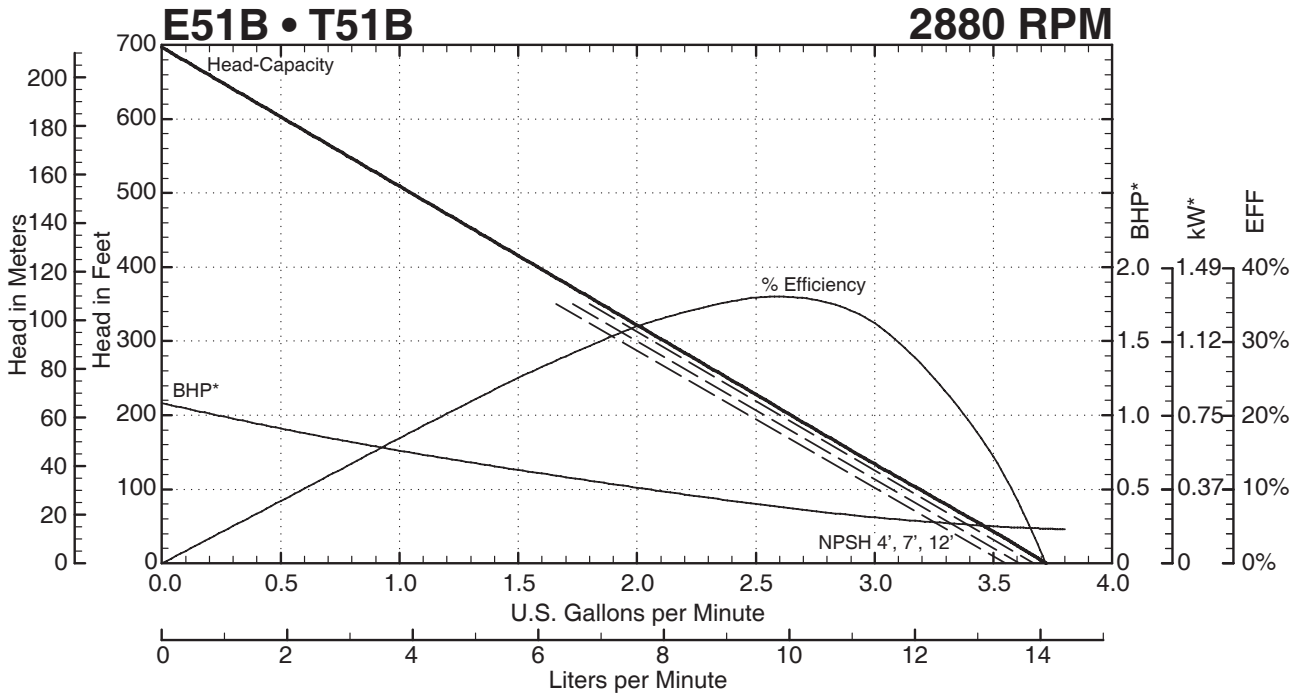

— — — Indicates altered performance at NPSH Available
 * Horsepower data is valid for 1.0 specific gravity fluids only



MTH PUMPS

401 West Main Street • Plano, IL 60545-1436
 Phone: 630-552-4115 • Fax: 630-552-3688
 Email: SALES@MTHPUMPS.COM
 http://WWW.MTHPUMPS.COM

T51 SERIES

Performance Curves

E51 • T51 SERIES PUMPS

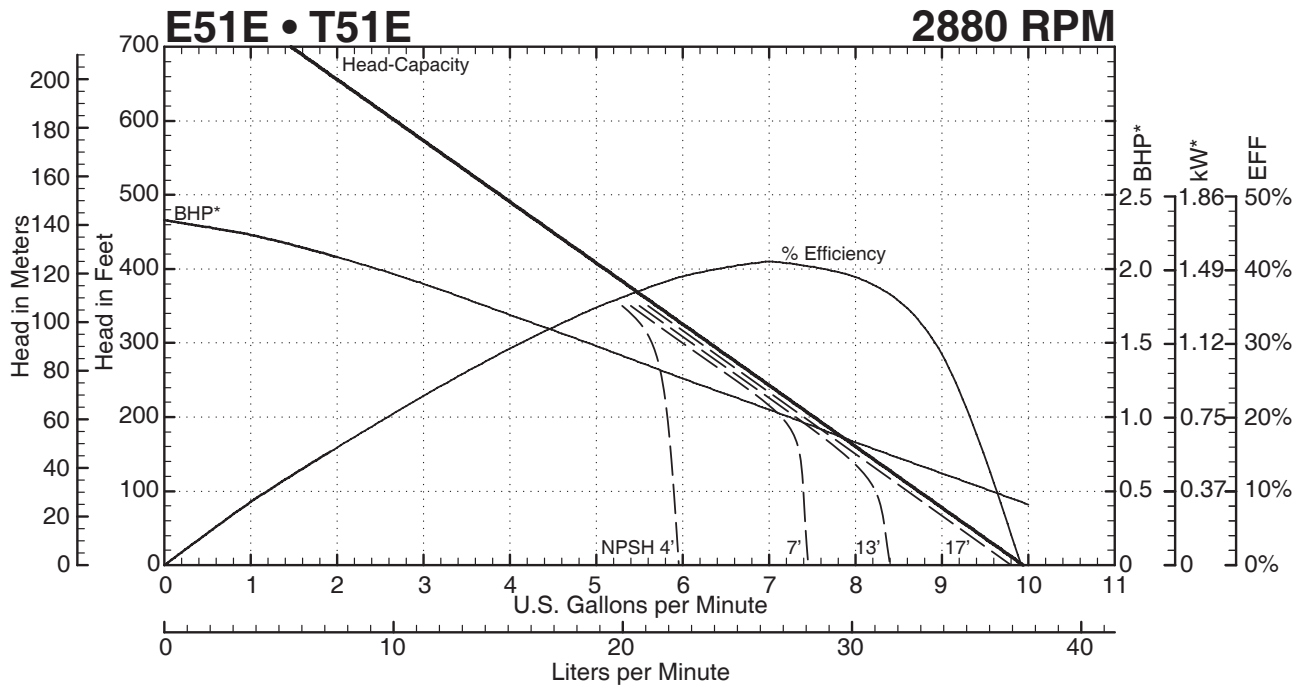
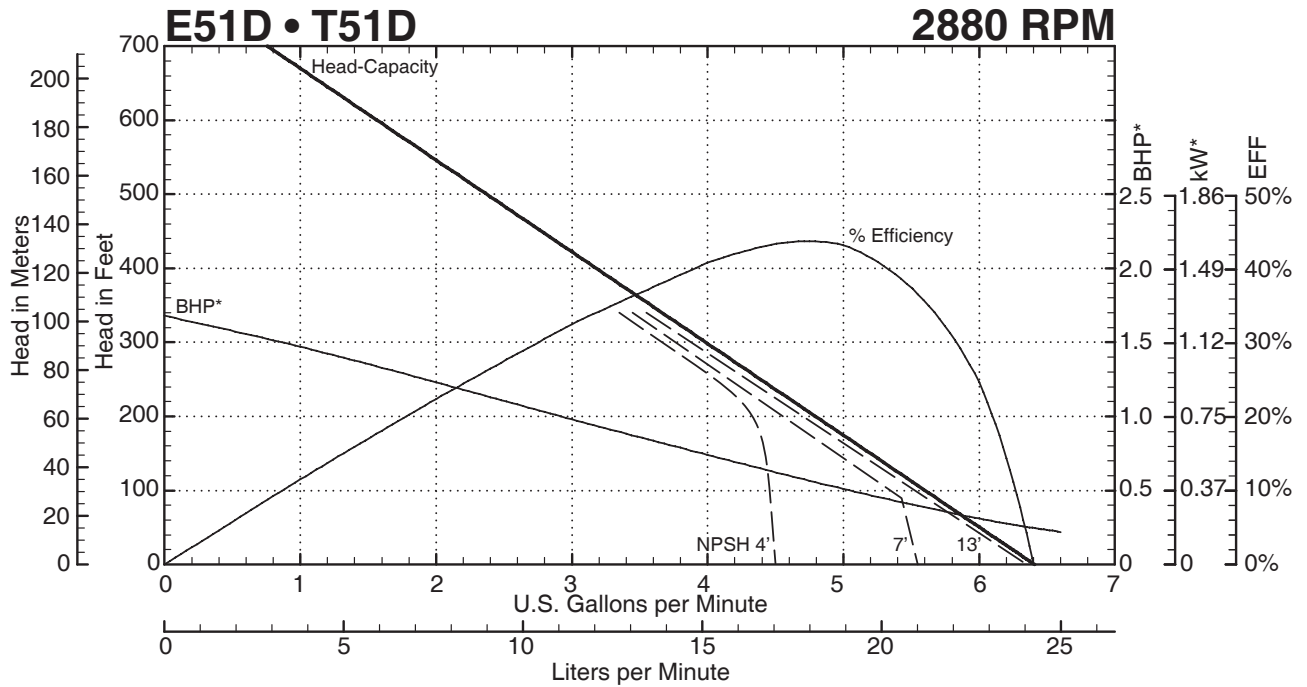

— — — — — Indicates altered performance at NPSH Available
 * Horsepower data is valid for 1.0 specific gravity fluids only



401 West Main Street • Plano, IL 60545-1436
 Phone: 630-552-4115 • Fax: 630-552-3688
 Email: SALES@MTHPUMPS.COM
<http://WWW.MTHPUMPS.COM>

T51 SERIES

Performance Curves

E51 • T51 SERIES PUMPS

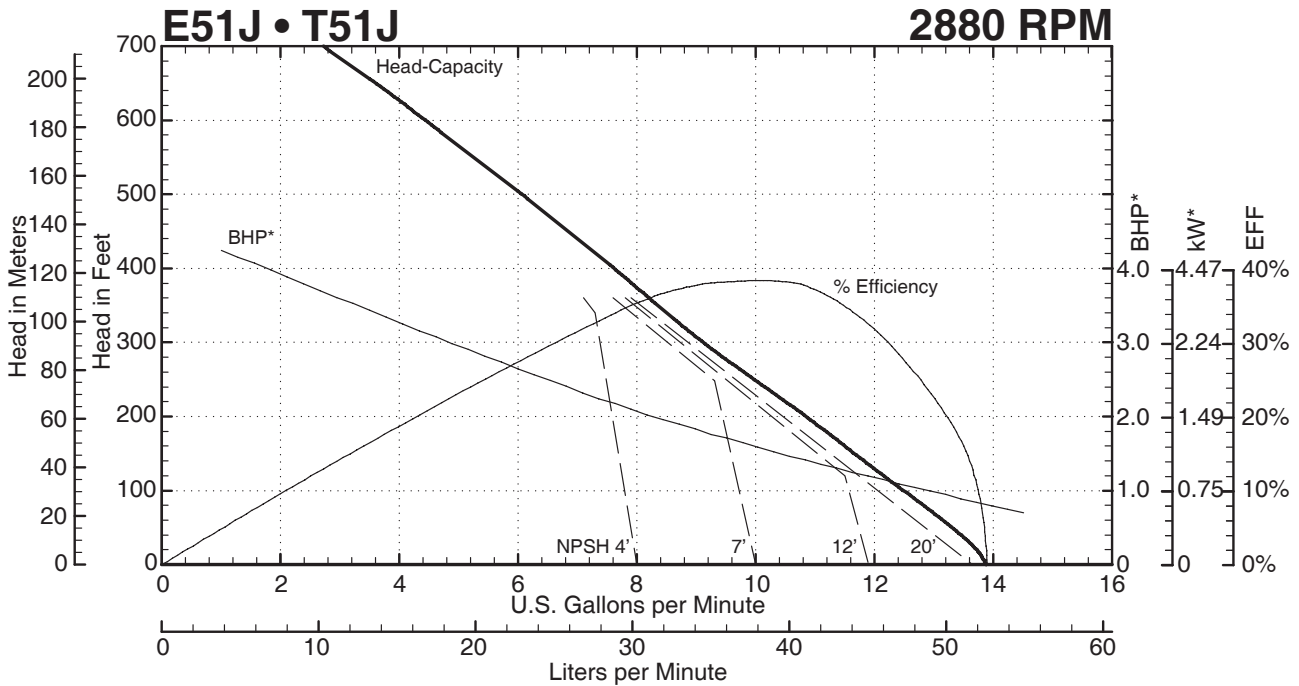
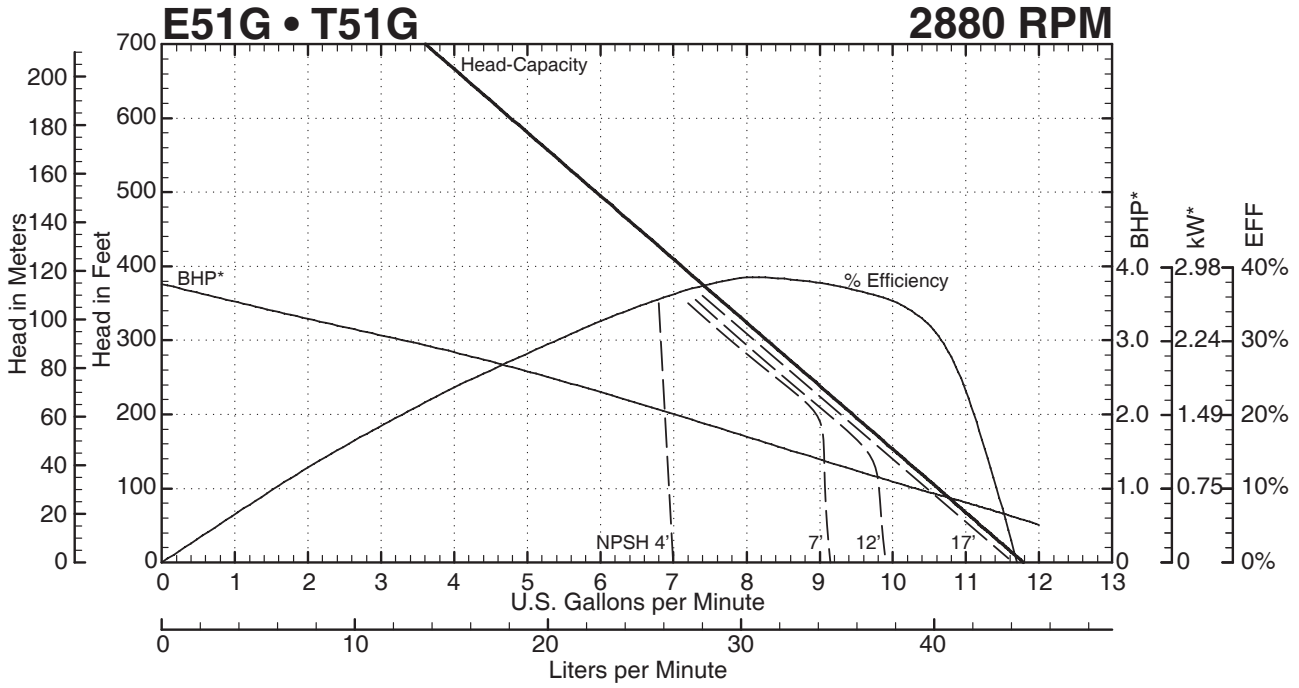

— — — — — Indicates altered performance at NPSH Available
 * Horsepower data is valid for 1.0 specific gravity fluids only



MTH PUMPS

401 West Main Street • Plano, IL 60545-1436
 Phone: 630-552-4115 • Fax: 630-552-3688
 Email: SALES@MTHPUMPS.COM
 http://WWW.MTHPUMPS.COM

T51 SERIES

Performance Curves

E51 • T51 SERIES PUMPS

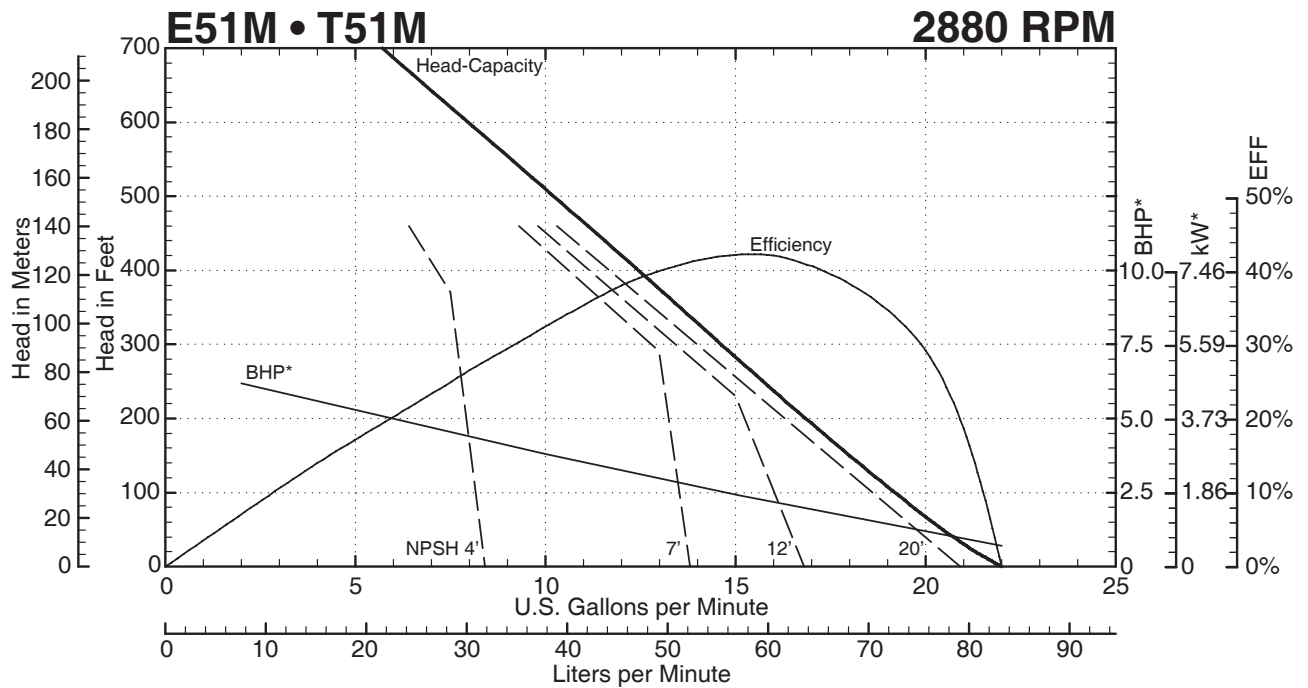
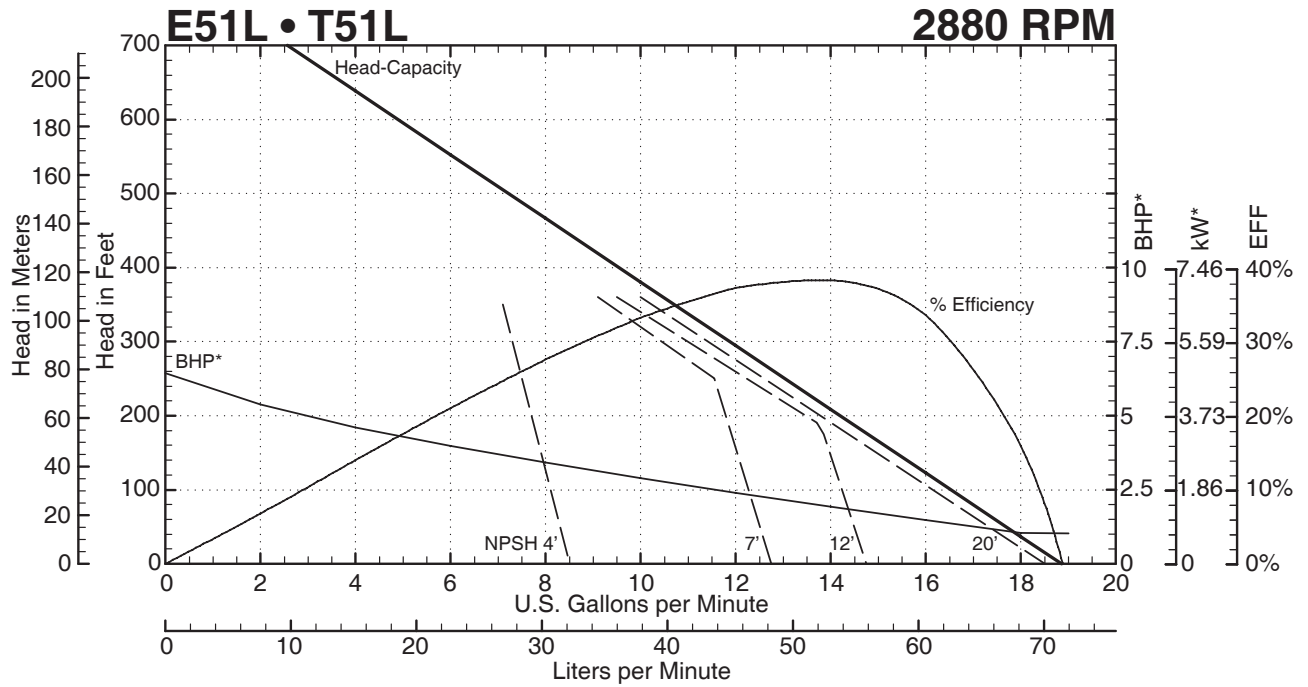

— — — — — Indicates altered performance at NPSH Available
 * Horsepower data is valid for 1.0 specific gravity fluids only

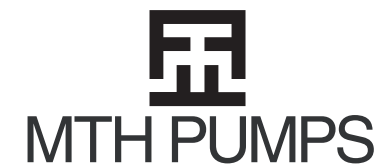

401 West Main Street • Plano, IL 60545-1436
 Phone: 630-552-4115 • Fax: 630-552-3688
 Email: SALES@MTHPUMPS.COM
 http://WWW.MTHPUMPS.COM

T51 SERIES

Performance Curves

E51 • T51 SERIES PUMPS

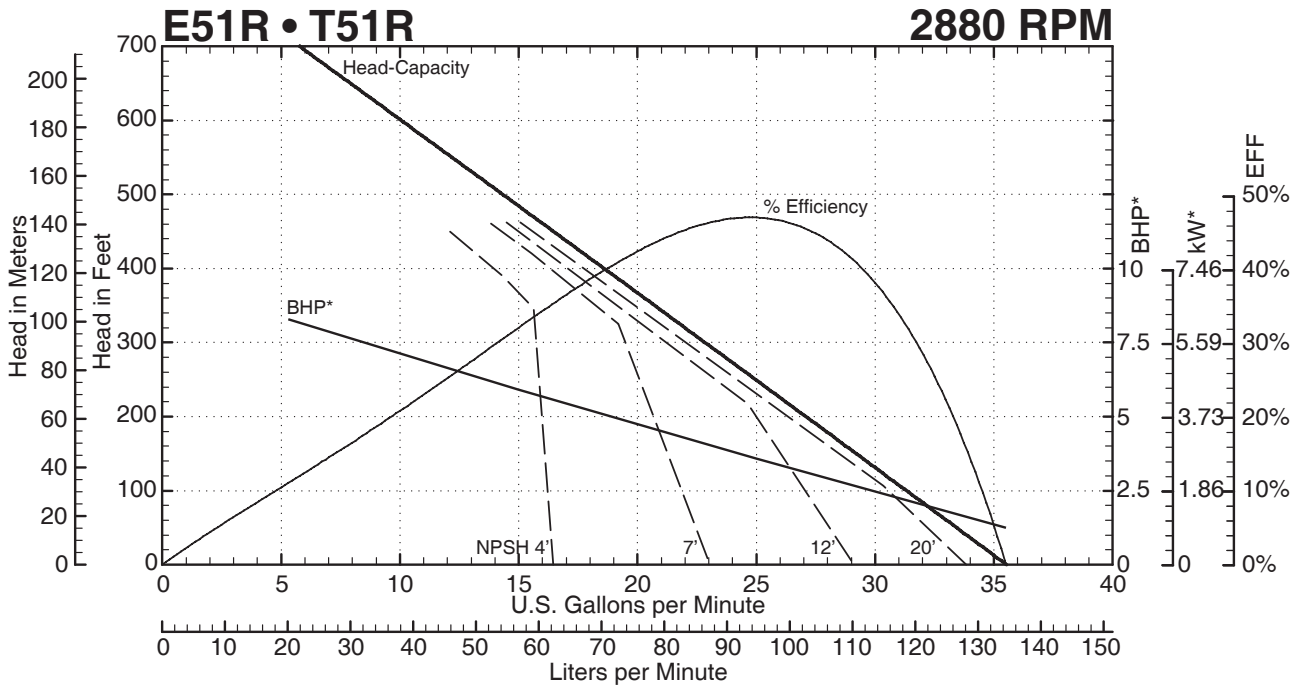
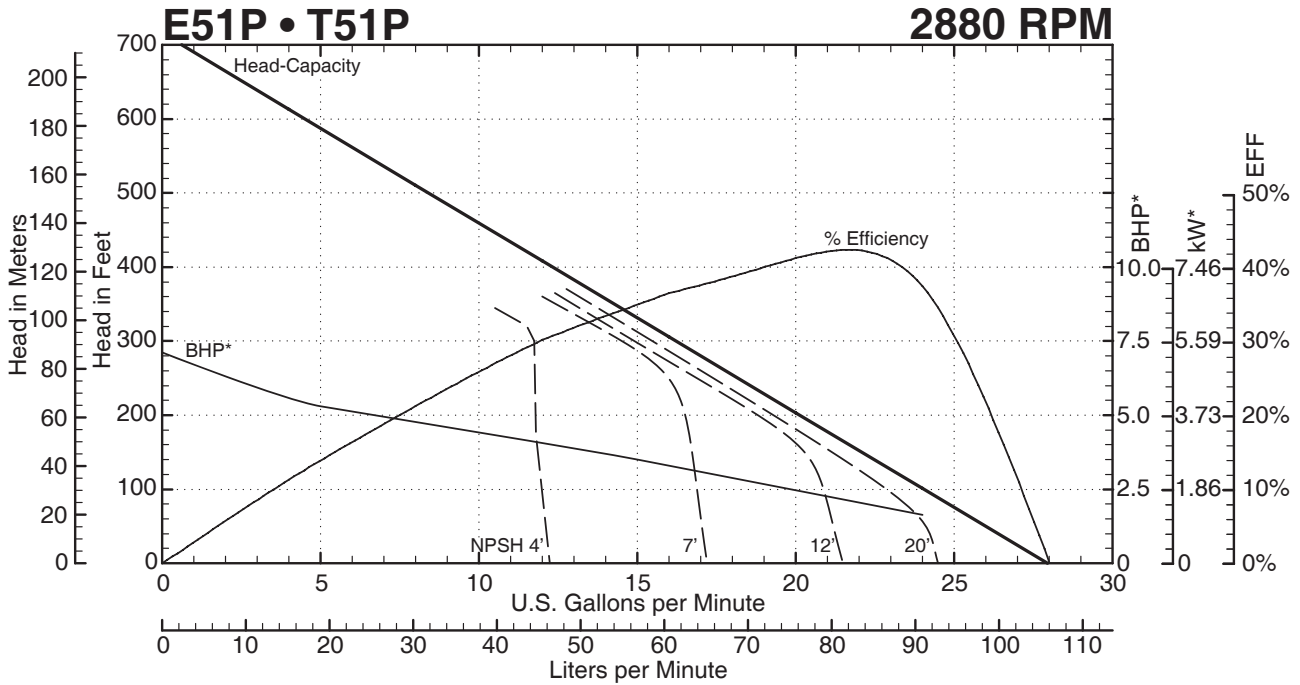

— — — — — Indicates altered performance at NPSH Available
 * Horsepower data is valid for 1.0 specific gravity fluids only



MTH PUMPS

401 West Main Street • Plano, IL 60545-1436
 Phone: 630-552-4115 • Fax: 630-552-3688
 Email: SALES@MTHPUMPS.COM
 http://WWW.MTHPUMPS.COM

T51 SERIES

Dimensions

T51 Horizontal Close Coupled

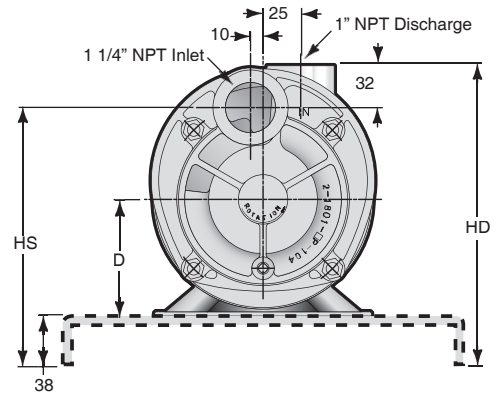
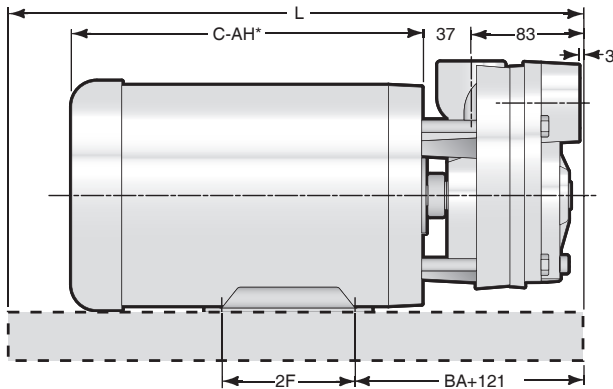
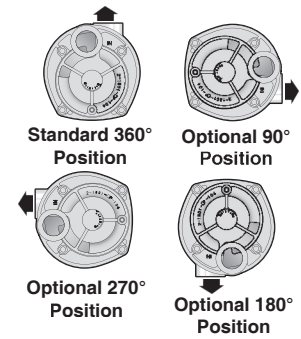
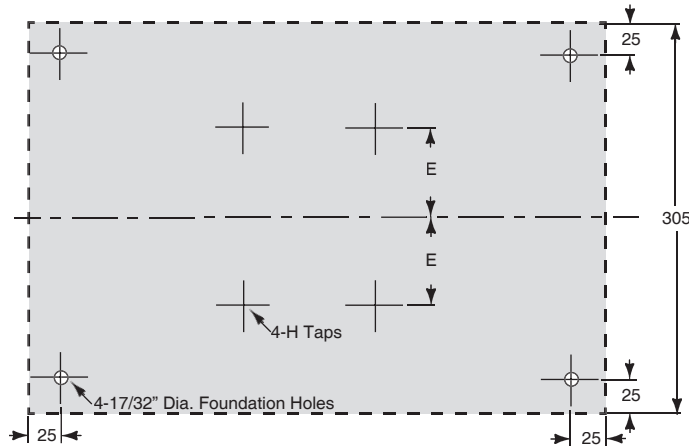

56C Thru 215TC Motor Frames

FRAME	D	BA+121	2F	E	H	HS	HD	L
56C	89	187	76	62	5/16 - 18	197	229	457
143 TC	89	194	102	70	5/16 - 18	197	229	457
145 TC	89	194	127	70	5/16 - 18	197	229	457
182 TC	114	213	114	95	3/8 - 16	222	254	508
184 TC	114	213	140	95	3/8 - 16	222	254	508
213 TC	133	232	140	108	3/8 - 16	241	273	559
215 TC	133	232	178	108	3/8 - 16	241	273	559

NOTES

All dimensions in millimeters. May vary ± 6 MM.
 Not for construction purposes unless certified.
 *See motor dimensions for "C-AH" dimension
 (varies depending on motor enclosure).



401 West Main Street • Plano, IL 60545-1436
 Phone: 630-552-4115 • Fax: 630-552-3688
 Email: SALES@MTHPUMPS.COM
 http://WWW.MTHPUMPS.COM

T51 SERIES

Dimensions

Flange Mounted Close Coupled

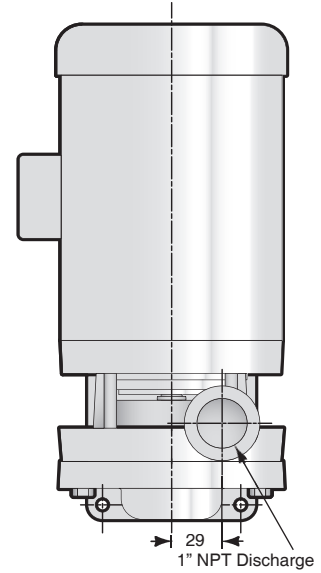
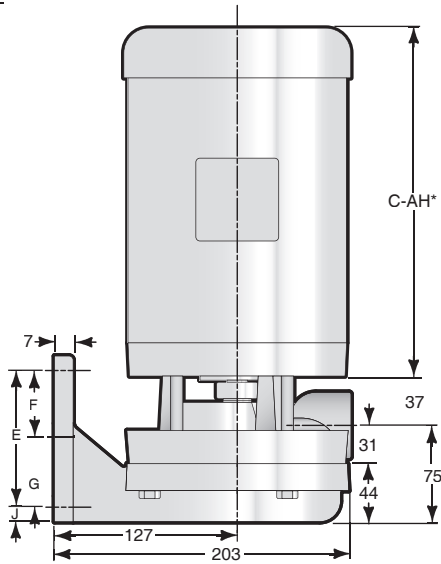
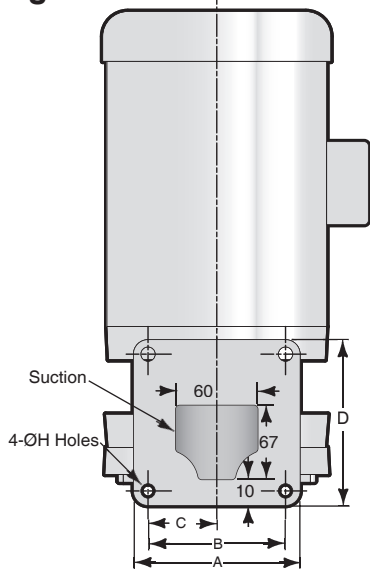

56C Thru 215TC Motor Frames

FLANGE STYLE	A	B	C	D	E	G	H	J
AU (7 1/2 x 4 1/2)	191	159	79	114	83	29	14	16
DB (4 1/2 x 4 1/2)	114	83	41	114	83	29	13	16
FE (7 3/4 x 4 3/4)	191	159	79	114	89	32	14	13
PA (6 1/2 x 3 3/4)	165	140	70	96	67	29	14	16
SH & BU (6 1/4 x 4)	159	127	64	102	70	29	14	16
SK (6 1/8 x 4 1/8)	156	127	64	105	68	25	14	19
ST (5 x 5)	127	95	48	127	95	29	13	16
WI (5 x 5)	127	105	52	127	105	33	11	11

E51 Horizontal Close Coupled

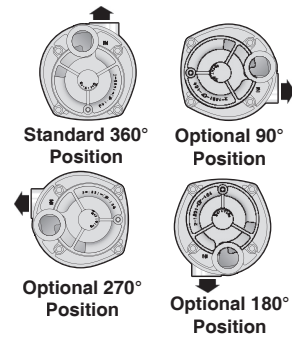
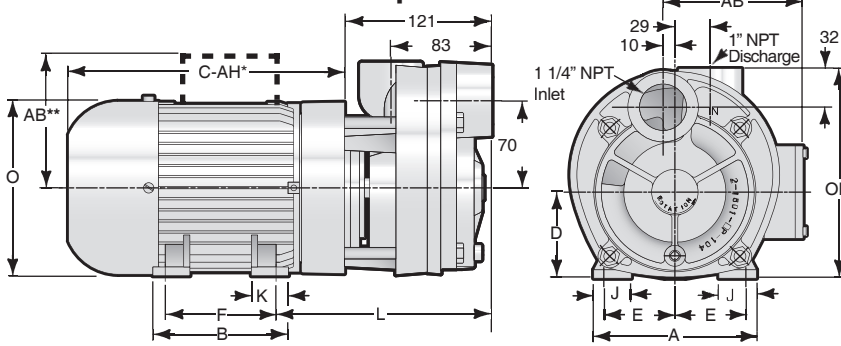

48 Thru 90 Motor Frames

FRAME	A	AB	B	D	E	F	J	K	L	O	OP
48	156	---	90	76	54	69	---	---	186	143	178
56	166	---	165	89	62	76	---	---	203	166	191
71	133	122	110	71	56	90	30	30	183	142	173
80	151	139	150	80	62	100	35	35	193	159	182
90	164	150**	150	90	70	125	36	42	184	178	192

**denotes conduit box mounted on top(90 frame only)

NOTES

All dimensions in millimeters. May vary ± 6 MM.
 Not for construction purposes unless certified.
 *See motor dimensions for "C-AH" dimension
 (varies depending on motor enclosure).



401 West Main Street • Plano, IL 60545-1436
 Phone: 630-552-4115 • Fax: 630-552-3688
 Email: SALES@MTHPUMPS.COM
 http://WWW.MTHPUMPS.COM

T51 SERIES Dimensions

P3 Bearing Frame

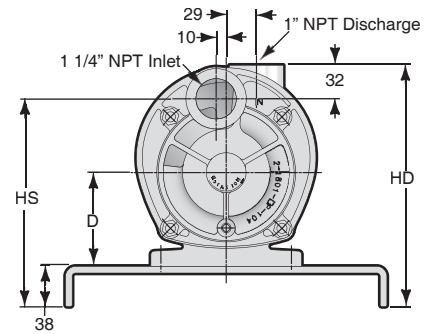
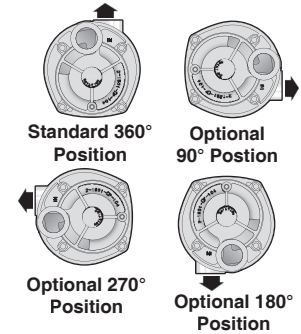
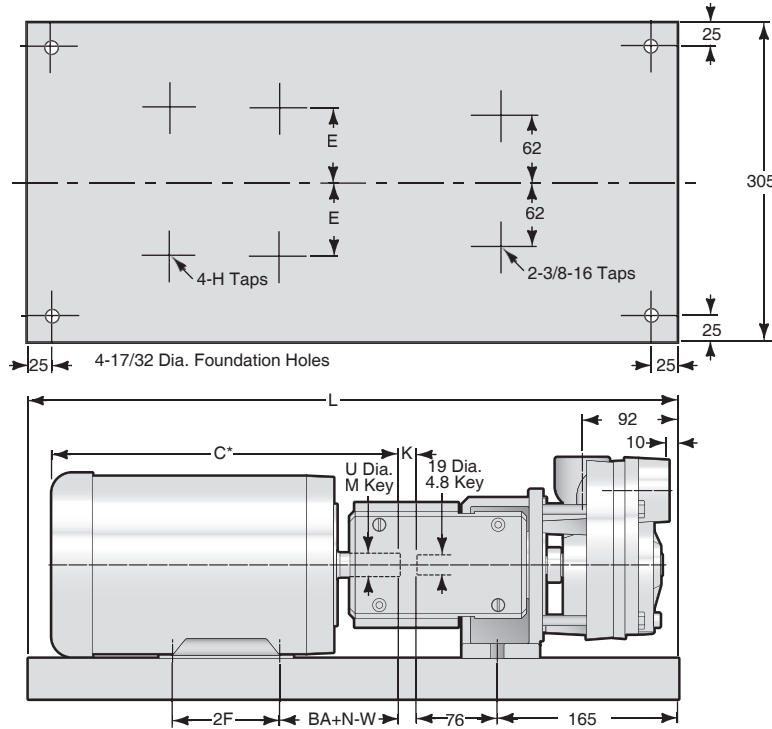

56T Thru 184T Motor Frames

FRAME	D	U	BA+N-W	2F	E	H	K	HS	HD	L	M
56 T	89	16	117	76	62	5/16 - 18	406	197	229	610	4.8
143 T	89	22	114	102	70	5/16 - 18	406	197	229	610	4.8
145 T	89	22	114	127	70	5/16 - 18	406	197	229	610	4.8
182 T	114	29	140	114	95	3/8 - 16	483	222	254	660	6
184 T	114	29	140	140	95	3/8 - 16	483	222	254	660	6

P3 Bearing Pedestal

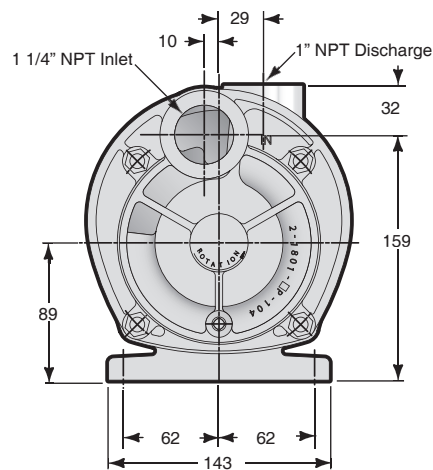
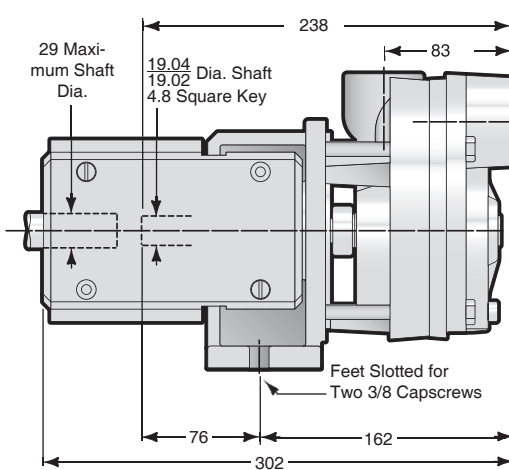

NOTES

All dimensions in millimeters. May vary ± 6 MM.
 Not for construction purposes unless certified.
 *See motor dimensions for "C" dimension
 (varies depending on motor enclosure).



401 West Main Street • Plano, IL 60545-1436
 Phone: 630-552-4115 • Fax: 630-552-3688
 Email: SALES@MTHPUMPS.COM
 http://WWW.MTHPUMPS.COM

T51 SERIES

Dimensions

E51 • T51 SERIES PUMPS

P15 Bearing Frame

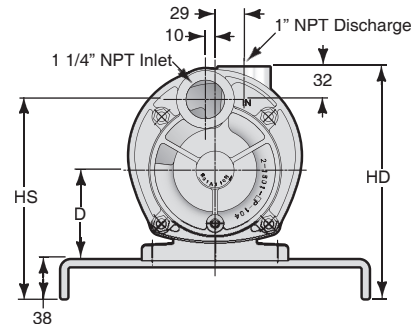
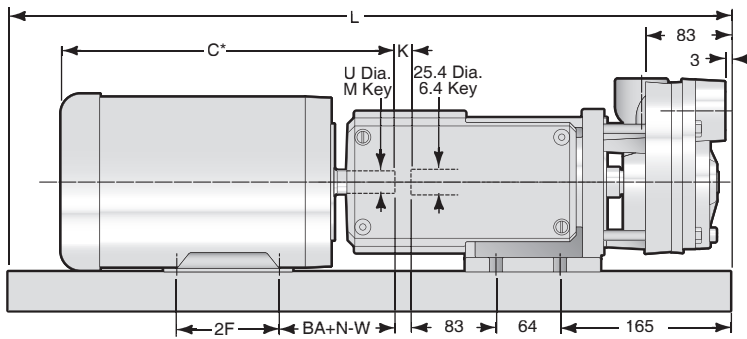
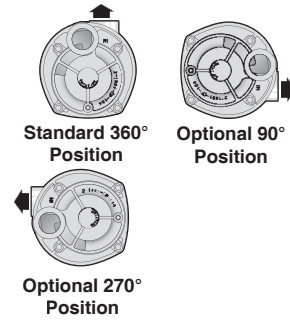
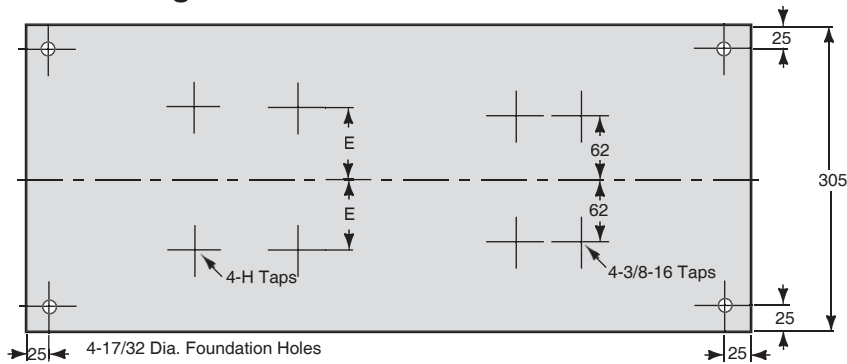

143T Thru 215T Motor Frames

FRAME	D	U	BA+N-W	2F	E	H	K	HS	HD	L	M
143 T	89	22	114	102	70	5/16 - 18	16	197	229	712	4.8
145 T	89	22	114	127	70	5/16 - 18	16	197	229	712	4.8
182 T	114	29	140	114	95	3/8 - 16	19	222	254	762	6.3
184 T	114	29	140	140	95	3/8 - 16	19	222	254	762	6.3
213 T	133	35	175	140	108	3/8 - 16	22	241	273	838	7.9
215 T	133	35	175	178	108	3/8 - 16	22	241	273	838	7.9

P15 Bearing Pedestal

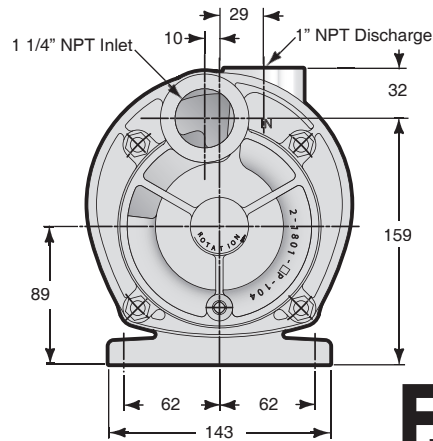
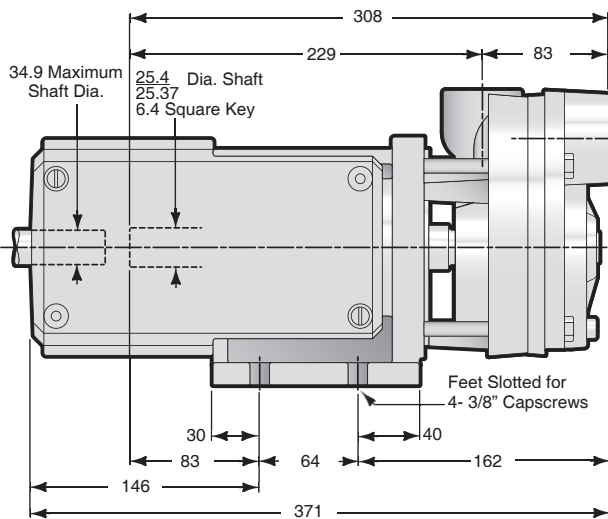

NOTES

All dimensions in millimeters. May vary ± 6 MM.
 Not for construction purposes unless certified.
 *See motor dimensions for "C" dimension
 (varies depending on motor enclosure).



MTH PUMPS

401 West Main Street • Plano, IL 60545-1436
 Phone: 630-552-4115 • Fax: 630-552-3688
 Email: SALES@MTHPUMPS.COM
 http://WWW.MTHPUMPS.COM