

Description

Ultra-high capacity load testing of generators or electric dynamometer testing of large engines and turbines is achieved with the Simplex Saturn Load Bank. The unit capacity range of the Saturn is 1500-3000KW, resistive, unity power factor. Saturns may be used singly or in systems of multiple units which yield total capacities of tens or hundreds of megawatts.

For unit loads less than 1500KW, use the Simplex Mars (to 1200KW), Neptune (to 650KW) or Polaris (to 250KW).

The Saturn is a single or dual voltage load bank suitable for all common 60 and 50 Hertz voltages up to 600V. Loads are stepped in any increment of 50KW, or, optionally, in fixed steps to 5KW or infinitely variable.

Cooling System: Using an ultra high volume forced air cooling system, up to 60,000CFM for the 3000KW Saturn, air temperature rise is limited to that seen in smaller load banks, in the 150-200°F range.

Features

- Self-contained load and control system
- Utilizes the proven Simplex "Powr-Web" load element (see page 2)
- Branch circuit fuse protection of load elements
- Digital load control (see page 4)
- Comprehensive malfunction detection system
- Color coded and numbered wiring; power wiring 150°C
- Plated bus bar
- UL Listed



Benefits

- Modular enclosure design with separate and isolated control and power sections
- Type 3R, oversize control section with generous cable connection space
- Vertical airflow, exhausts hot air above level of personnel and away from buildings, pavement etc.
- Slide-out, tray mounted load elements
- Comprehensive overload, short circuit and malfunction protection
- Highly standardized, based upon extensive product line spanning from 5KW to 3MW
- Supported by comprehensive engineering and product support, including detail manuals, 24 hour field service, availability of start-up services.

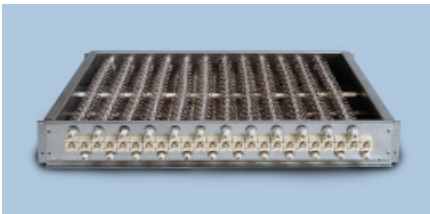

Powr-Web Resistive Load Element

Description

Simplex Load Banks utilize “Powr-Web” load elements. The “Powr-Web” is an advanced design, air-cooled power resistor specifically designed for application to Load Bank systems. The “Powr-Web” is conservatively operated at half the maximum temperature rating of the alloy and features a short-circuit-safe design based on continuous mechanical support of the element by high temperature, ceramic clad stainless steel rods. The “Power Webs” are assembled into discrete trays which are assembled in a vertical “stack.” Each tray in the “stack” is independently serviceable without disturbing adjacent trays.

Specifications

- Alloy: FeCrAl
- Maximum continuous temperature rating: 1920°F
- Maximum operating temperature as applied in Load Bank: 1080° F
- Cool down time from operating to ambient temperature is 10 seconds.

Construction

- Ceramic clad, stainless steel through-rods.
- UL Recognized

Capacity:	1500KW, 1800KW, 2000KW, 2250KW, 2500KW, 3000KW; Resistive; 1.0 power factor
Voltage:	All common 3-phase 60 and 50 Hz voltages: 60 Hertz: 208V, 220V, 240V, 416V, 440V, 450V, 460V, 480V, 575V, 600V, 50 Hertz: 190V, 200V, 208V, 380V, 400V, 416V
Frequency:	50 and 60 Hz
Load Steps:	50 KW resolution standard. 1-5-10-25KW resolution available.
Duty Cycle:	Continuous
Temperature:	125°F maximum ambient temperature Exhaust rise: $RISE = KW \times 3000 / CFM$ (note: as airflow is not laminar, exhaust air temperatures are not equal at all points at the plane of air exhaust. Some parcels of air may reach approximately 575°F before mixing)
Airflow:	1500-1800KW: 40,000 CFM, 1800-2000KW: 50,000 CFM, 2500-3000KW: 60,000 CFM
Fan/Control:	Internal, from load bus. Control circuits at 120V via transformer. The cooling fan operates at 3-phase line voltage. Load control circuits and fan motor control operate at 120V. Control circuits are fused. Control circuit fuses are 100,000 A.I.C., 600V rated. External, 480/240V, supply for humidity controller, when ordered.

Principle Systems and Components

The load bank is a completely self-contained, freestanding unit which includes all resistive load elements, load control devices, load element branch circuit fuse protection, main load bus and terminals, cooling system, control power supply, unit controller and malfunction detection system and NEMA type enclosure.

Load elements

Simplex "Powr-Web" open wire, helically wound, chromium alloy, thermally derated to 60%. 5% tolerance, 2% balance, .995 p.f.

UL Recognized.

Load control

Branch circuit contactors, each 50 KW step. Contactors have enclosed silver surfaced contacts, 120V coils; electrically operated and electrically held.

Element circuit protection

Branch circuit fuses, each 50KW branch circuit, 70A, 200kAIC, current limiting type.

Power wiring

150°C insulated; color coded.

Control wiring

105°C, color coded.

Power connection

Plated bus bar within an oversize terminal junction box.

Cooling

Forced air, vertical airflow, top exhaust. 3-phase, TEFC motor driving cast aluminum fan blade. Circuit breaker combination motor starter.



System protection

Fan failure, high exhaust temperature, high intake temperature; lockout and alarm.

Enclosure

Modular enclosure consists of three parts:

1. NEMA-3R rainproof power section including load elements and cooling fan
2. NEMA-3R control section, thermally and electrically isolated from power section
3. Exhaust hood. Mounts atop power section. Vertical flow with rain separators. Hood may be deleted and a duct flange provided for indoor applications where air is exhausted through a duct to the outdoors.

All panels for access to serviceable components are hinged doors with stainless steel hinges and lockable latches. All exterior fasteners are stainless steel.

The load bank enclosure is of double wall construction for cool exterior and thermal isolation of the load elements. Cooling airflow through the enclosure is vertical with cold air intake at the bottom and hot air exhaust out the top. Intake and exhaust openings are screened. All parts of the enclosure are abrasive blasted or chemically etched, primed and finished with a color as specified. The exhaust hood which is exposed to high air temperatures is unpainted galvanized steel.

Dimensions and Key Features

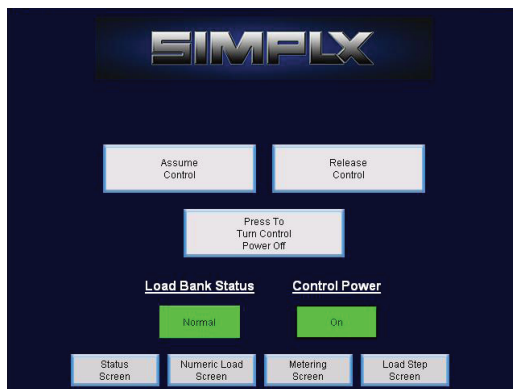
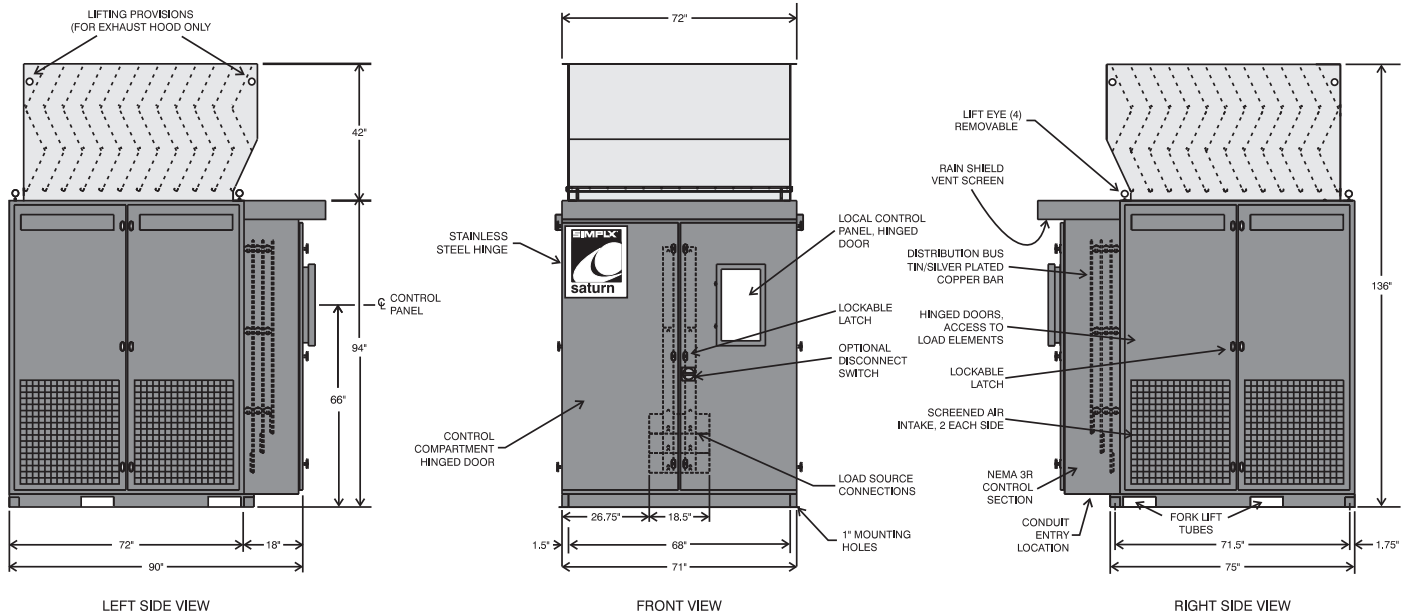

D-Series, Digital Load Controller

With D-Series controllers, the user enjoys a significant savings of installation cost. Versus traditional analog (toggle switch) panels, connections for remote control are reduced to a single RS-485 or Ethernet Cat-5 cable. Multiple control stations are easily networked. Valuable space is conserved. Reliability is enhanced.

The D-Series accepts Simplex "Auto-Test" software enabling full automation of load bank testing with data acquisition, report generation and pass-fail testing. Inputs from generator controller data outputs can be accepted to allow integration of full engine data.

Features

- Standard control system for Simplex Stationary Load Banks
- PLC based
- Color TFT touchpanel operator interface featuring bright colors, excellent contrast and wide viewing angle, perfect for bright sunlight and low light conditions
- Easy upgrades for load bank automation
- Network capable
- IP address capable
- PC integration software available
- MODBUS RTU over RS-485 or Ethernet network communications



With D-Series controllers, data monitoring and acquisition, load bank automation and BMS integration are made simple. The D-Series is networked via MODBUS RTU over RS-485 or Ethernet allowing simple daisy chain or Ethernet switch cable networking. MODBUS-to-BacNet (or other protocol) converters are available.

The D-Series controller can be accessed by remote PC by simple assignment of an IP address.

PC integration software is available.