

## Water Feeders – Make-Up

### Series 21 Make-Up Water Feeder

- For boiler receiver tanks
- Direct mounting eliminates need for equalizing connections
- Proportional feed action
- Mounting Flange – six  $\frac{7}{16}$ " (11.1mm) bolt holes on a  $5\frac{3}{4}$ " (146mm) bolt circle
- Soft seat provides positive seal
- Maximum water supply pressure 150 psi (10.5 kg/cm<sup>2</sup>)
- Maximum inlet water temperature 120°F (49°C)
- Maximum vessel pressure 35 psi (2.5 kg/cm<sup>2</sup>)



Series 21

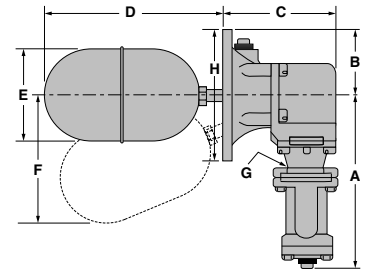

### Dimensions, in. (mm)

| A        | B       | C        | D           | E        | F        | G<br>NPT | H        |
|----------|---------|----------|-------------|----------|----------|----------|----------|
| 8½ (216) | 3⅝ (84) | 5⅝ (143) | 8⅓/16 (224) | 4¾ (121) | 6¼ (159) | ¾        | 7⅝ (186) |

### Series 221 Make-Up Water Feeder

- For boiler receiver tanks
- Direct mounting eliminates need for equalizing connections
- Proportional feed action
- Mounting Flange – six  $\frac{17}{32}$ " (13.5mm) bolt holes on a  $8\frac{1}{2}$ " (216mm) bolt circle
- Soft seat provides positive seal
- Maximum water supply pressure 150 psi (10.5 kg/cm<sup>2</sup>)
- Maximum inlet water temperature 120°F (49°C)
- Maximum vessel pressure 35 psi (2.5 kg/cm<sup>2</sup>)



Series 221

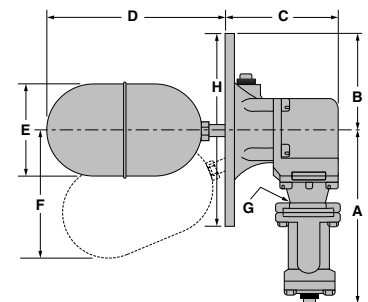

### Dimensions, in. (mm)

| A        | B        | C        | D           | E        | F        | G<br>NPT | H        |
|----------|----------|----------|-------------|----------|----------|----------|----------|
| 8½ (216) | 4⅞ (124) | 5⅝ (143) | 8⅓/16 (224) | 4¾ (121) | 6¼ (159) | ¾ (20)   | 9½ (241) |

### Capacities

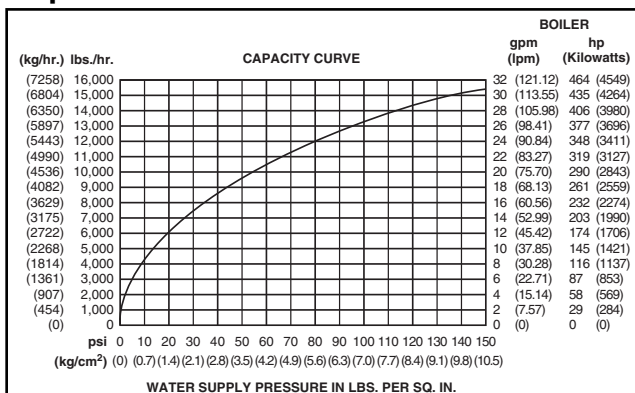

### Ordering Information

| Model Number | Part Number | Description          | Weight lbs. (kg) |
|--------------|-------------|----------------------|------------------|
| 21           | 126400      | Make-up water feeder | 15.3 (6.9)       |
| 221          | 126600      | Make-up water feeder | 21.3 (9.7)       |

Boiler Controls